

Performance analysis of on-demand pressurized irrigation systems

FAO
IRRIGATION
AND DRAINAGE
PAPER

59



CIHEAM
International Centre
for Advanced
Mediterranean
Agronomic Studies
IAMB
Bari Institute

Food
and
Agriculture
Organization
of
the
United
Nations



Performance analysis of on-demand pressurized irrigation systems

FAO
IRRIGATION
AND DRAINAGE
PAPER

59

by

Nicola Lamaddalena

Chief

Hydraulic Engineering Service

CIHEAM-Bari Institute

and

J.A. Sagardoy

Senior Technical Officer (Water Management)

Water Resources, Development and Management Service

FAO Land and Water Development Division



CIHEAM
International Centre
for Advanced
Mediterranean
Agronomic Studies
IAMB
Bari Institute

Food
and
Agriculture
Organization
of
the
United
Nations



Rome, 2000

The designations employed and the presentation of material in this publication do not imply the expression of any opinion whatsoever on the part of the Food and Agriculture Organization of the United Nations or the International Centre for Advanced Mediterranean Agronomic Studies-Bari Institute concerning the legal status of any country, territory, city or area or of its authorities, or concerning the delimitation of its frontiers or boundaries.

ISBN 92-5-104437-6

All rights reserved. No part of this publication may be reproduced, stored in a retrieval system, or transmitted in any form or by any means, electronic, mechanical, photocopying or otherwise, without the prior permission of the copyright owner. Applications for such permission, with a statement of the purpose and extent of the reproduction, should be addressed to the Director, Information Division, Food and Agriculture Organization of the United Nations, Viale delle Terme di Caracalla, 00100 Rome, Italy.

Foreword

Pressurized irrigation systems working on demand were the object of considerable attention in the sixties and seventies and a considerable number of them were designed and implemented in the Mediterranean basin mainly but also in other parts of the world. They offer a considerable potential for efficient water use, reduce disputes among farmers and lessen the environmental problems that may arise from the misuse of irrigation water. With the strong competition that is arising for the water resources, modernization of irrigation systems is becoming a critical issue and one of the alternatives to modernize is the use of pressurized systems to replace part of the existing networks. This approach is being actively pursued in many countries.

Much of the work done in the past concentrated in the design and optimization of such systems and FAO through its Irrigation and Drainage Paper 44: "Design and optimization of irrigation distributions networks" (1988) contributed substantially to this area of knowledge. However, practically no tool existed to analyse the hydraulic performance of such systems, which are very complex due to their constantly varying conditions, until few years ago where the new computer generations permitted complex simulations.

The present work was started with the idea of developing such tool based in the great capacity of computers to generate randomly many situations which could be analysed statistically and provide clear indications of where the network was not functioning satisfactorily. However this work put rapidly in evidence that the same criteria could also be used to analyse a network designed according to traditional criteria and improve the design. This led to the conclusion that the design criteria also needed revision and this additional task was also faced and completed.

The present publication, therefore, has as its main objective the development of a computer tool that permits the diagnosis of performance of pressurized irrigation systems functioning on demand (also under other conditions), but also provides new and revised criteria for the design of such irrigation networks. The publication intends to be complementary to Irrigation and Drainage Paper 44 and where necessary the reader is referred to it for information or methodologies that are still valid.

An effort has been made to reduce the development of formulae but the subject is complex and their use is unavoidable. Calculations examples have been included to demonstrate the calculation procedures and facilitate the understanding and practical use of formulae. The computer program (COPAM) performs these calculations in a question of seconds but it is important that the user has full understanding of what is being done by the program and has the capacity to verify the results.

The computer model has been tested in several field situations in the Mediterranean basin. It has proved its usefulness not only by quickly identifying the weak points of the network but also by identifying the power requirements of pumping stations needed to satisfy varying demand situations and often proving that the powerhouses were not well suited (overdesigned or underdesigned) to meet the requirements of the network.

The present publication is intended to provide new methods for the design and analysis of performance of pressurized irrigation systems, and should be of particular interest to district managers, consultants irrigation engineers, construction irrigation companies, university professors and students of irrigation engineering and planners of irrigation systems in general.

Comments from potential users are welcomed and should be addressed to:

Chief
Water Resources, Development and Management Service
FAO, Viale delle Terme di Caracalla
00100 Rome, Italy

or to

Chief
Hydraulic Engineering Service
CIHEAM – Bari Institute
Via Ceglie 9, 70010 Valenzano (Bari), Italy.

Acknowledgements

The past involvement of FAO in the subject of this publication, the potential that the subject offers for the future modernization of irrigated agriculture and the interest and experience of the CIHEAM in this area have made it particularly suitable for the association of both organizations in the preparation of this publication, which was of mutual interest.

The author wishes to acknowledge the Director of CIHEAM-Bari Institute and the Director of the Land and Water Development Division of FAO for the continuous support to the undertaking of this activity.

Special mention is due to several students who have participated over the years in the Engineering Master courses at the CIHEAM-Bari Institute and have contributed to the evolution of the modelling approaches presented in this paper.

Special thanks are due to L.S. Pereira, Professor at the Technical University of Lisbon (Portugal) and to M. Air Kadi, Secretary General at the Ministry of Agriculture of Rabat (Morocco) who have been the source of constant inspiration and advice.

Special thanks are also due to the reviewers of the publication, Messrs J.M. Tarjuelo, Professor of the University of Castilla-La Mancha, Spain, T. Facon, Technical Officer, FAO Regional Office for Asia and the Pacific, and R.L. Snyder, Professor, University of California.

This work is dedicated to the memory of Yves Labye who contributed greatly to the scientific background of the approaches used in the present paper and whose works still remain an outstanding intellectual reference.

Contents

	page
1 ON-DEMAND IRRIGATION SYSTEMS AND DATA NECESSARY FOR THEIR DESIGN	1
Main criteria to design a distribution irrigation system	2
Layout of the paper	6
2 NETWORK LAYOUT	9
Structure and layout of pressure distribution networks	9
Design of an on-demand irrigation network	9
Layout of hydrants	9
Layout of branching networks	9
Optimization of the layout of branching networks	10
Methodology	10
Applicability of the layout optimization methods	13
3 COMPUTATION OF FLOWS FOR ON-DEMAND IRRIGATION SYSTEMS	15
One Flow Regime Models (OFRM)	16
Statistical models: the Clément models	16
The first Clément model	16
The second Clément model	32
Several Flow Regimes Model (SFR Model)	39
Model for generating random discharges	39
4 PIPE-SIZE CALCULATION	43
Optimization of pipe diameters with OFRM	43
Review on optimization procedures	43
Labye's Iterative Discontinuous Method (LIDM) for OFR	45
Optimization of pipe diameters with SFRM	54
Labye's Iterative Discontinuous Method extended for SFR (ELIDM)	55
Applicability	58
The influence of the pumping station on the pipe size computation	58
The use of COPAM for pipe size computation	59
Sensitivity analysis of the ELIDM	63
5 ANALYSIS OF PERFORMANCE	67
Analysis of pressurized irrigation systems operating on-demand	67
Introduction	67
Indexed characteristic curves	67
Models for the analysis at the hydrant level	79
Reliability indicator	92

6 MANAGEMENT ISSUES	97
Some general conditions for a satisfactory operation of on-demand systems	97
Suitable size of family holdings	97
Medium to high levels of irrigation and farm management knowledge	97
Volumetric pricing	98
Correct estimation of the design parameters	98
Reduced energy costs	98
Qualified staff for the operation and maintenance of the system	99
The on-demand operation during scarcity periods	99
Volumetric water charges	101
Water meters	102
Types of volumetric charges	102
Recovery of investments through the volumetric charge	103
The operation, maintenance and administration costs	103
The maintenance of the pumping stations and related devices	104
Flow and pressure meters:	104
Pumps:	104
Compressors:	105
Switchboards:	105
Ancillary works:	105
The maintenance of the irrigation network	105
Towards the use of trickle irrigation at the farm level in on-demand irrigation systems	105
New trends and technologies of delivery equipment	106
BIBLIOGRAPHY	109
ANNEX 1 VALIDATION OF THE 1ST CLÉMENT MODEL	115
ANNEX 2 PIPE MATERIALS AND DESIGN CONSIDERATIONS	125
ANNEX 3 EXAMPLE OF INPUT AND OUTPUT FILES	131

List of figures

	page
1. Scheme of the main steps of an irrigation project	4
2. The chronological development process of an irrigation system	5
3. Sound development process of an irrigation system	6
4. Synthetic flow chart of COPAM	7
5. Proximity layout: application of Kruskal's algorithm	11
6. Proximity layout: application of Sollin's algorithm	11
7. 120° layout – case of three hydrants	11
8. 120° layout – case of four hydrants	12
9. 120° layout – case of four hydrants (different configuration)	13
10. Variation of the elasticity of the network, e_R , versus the total number of hydrants for different values of r and e_h , for $U(P_q) = 1.645$	20
11. COPAM icon	24
12. First screen of the COPAM package	24
13. Layout of the COPAM package	25
14. File menu bar and its sub-menu options	25
15. Edit menu bar and its sub menu items	26
16. Sub menu Edit/Hydrants discharge	27
17. Examples of node numbering	28
18. Edit/network layout sub-menu	29
19. Edit list of pipes sub-menu	30
20. Edit description sub-menu	30
21. Toolbar button “Check input file”	31
22. Clément parameters: 1 st Clément formula	32
23. Diagram representing u' as a function of $F(u')$	34
24. Clément parameters: 2 nd Clément formula	37
25. Comparison between discharges computed with the 1 st and the 2 nd Clément equations applied to the Italian irrigation network illustrated in Annex 1	38
26. Probability of saturation versus the 1 st Clément model discharges	38
27. Operation quality, $U(P_q)$ versus the 2 nd Clément model discharges	39
28. Typical layout of a network	40
29. Random generation program	41
30. Random generation parameters	42
31. Characteristic curve of a section	46
32. Characteristic curve of a section	47
33. Elementary scheme	55
34. Costs (10^6 ITL) of the network in the example, calculated by using the ELP and the ELIDM for different sets of flow regimes	58
35. Optimization of the pumping station costs	59
36. Pipe size computation program	60
37. Optimization program: “Options” Tab control	60
38. Optimization program: “Mixage” Tab control	61

	page
39. Optimization program: “Data” Tab control	62
40. Input file: Edit network layout	62
41. Optimization program: “Options” Tab control	63
42. Optimization program: “Data” Tab control	64
43. Optimization program: “Options” Tab control	64
44. Layout of the network	65
45. Cost of the network as a function of the number of configurations. The average costs and the confidence interval concern 50 sets of discharge configurations.	66
46. Characteristic curve of a hydrant	68
47. Characteristic curve of a hydrant	69
48. Characteristic curves program	70
49. Characteristic curves program: parameters of the analysis	71
50. Input file: edit network layout	72
51. Graph menu bar and sub-menu items	72
52. Open file to print the characteristic curves	73
53. Indexed characteristic curves of the irrigation system under study	74
54. Scheme of a pumping station equipped with variable speed pumps	76
55. Characteristic curves of variable speed pumping station and the 93% indexed characteristic curve of the network	77
56. Power required by the plant equipped with variable speed pumps (type A) and a classical plant (type B), as a function of the supplied discharges	77
57. Indexed characteristic curves for the Lecce irrigation network computed using 500 random configurations	78
58. Flow chart of AKLA	81
59. Curves representative of the percentage of unsatisfied hydrants (PUH) versus the discharge, for different probabilities for PUH to be exceeded	82
60. Curves representative of the upstream piezometric elevation ($Z_{0,1} < Z_{0,2} < Z_{0,3} < Z_{0,4}$) with the variation of the percentage of unsatisfied hydrants (PUH), for an assigned probability of occurrence	82
61. Curves representative of the percentage of unsatisfied hydrants (PUH) with the variation of the upstream piezometric elevation ($Z_{0,1} < Z_{0,2} < Z_{0,3} < Z_{0,4}$), for an assigned probability of occurrence	83
62. Relative pressure deficits for every hydrant in the network	83
63. Relative pressure deficits for every hydrant in the network	84
64. Hydrants analysis program: “Options” Tab control, “Several-random generation” flow regime	84
65. Hydrants analysis program: “Options” Tab control, “Several-read from file” flow regime	85
66. Hydrants analysis program: “Set point” Tab control	86
67. Hydrant analysis program: “Elevation-discharge” Tab control	86
68. “Graph” menu bar and sub-menu items	87
69. Indexed characteristic curves for the irrigation network under study, computed using 500 random hydrants configurations	88
70. Curves of the probabilities that a given percentage of unsatisfied hydrants (PUH) be exceeded, computed using 500 random configurations. Upstream elevation $Z_0 = 81.80$ m a.s.l	89
71. Curves representative of the percentage of unsatisfied hydrants (PUH), with 10% of probability to be exceeded, with the variation of the upstream piezometric elevation from 60 up to 110 m a.s.l.	90

72. Relative pressure deficits at each hydrant when 500 discharge configurations were generated. Discharge $Q_0=675 \text{ l s}^{-1}$ and upstream piezometric elevation $Z_0=81.80 \text{ m a.s.l}$	91
73. Variation of the relative pressure deficit at each hydrant in each discharge configuration	91
74. Analysis with 200 random configurations of 50 l s^{-1}	94
75. Analysis with 200 random configurations of 60 l s^{-1}	95
76. Relative pressure deficits obtained with the model AKLA and 90% envelope curves. Analysis of the networks with 200 random configurations of 50 l s^{-1}	95
77. Relative pressure deficits obtained with the model AKLA and 90% envelope curves. Analysis of the networks with 200 random configurations of 60 l s^{-1}	96
78. Typical demand hydrographs at the upstream end of an irrigation sector: a) on-demand operation; b) arranged demand operation	100
79. Cross-section of a hydrant	103
80. Scheme of a delivery device controlled by an electronic card	107

List of tables

	page
1. Standard normal cumulative distribution function	18
2. Discharges flowing into each section of the network under study (output of the COPAM package: computation with the first Clément model)	21
3. Discharges flowing into each section of the network under study (output of the COPAM package: computation with the second Clément model)	37
4. Elementary scheme	57
5. Comparing the power requirements for a pumping plant equipped with variable speed pumps (type A) and for a classical pumping plant (type B), as a function of the discharges supplied	75

List of symbols

A	irrigated area	[ha]
C	number of configurations	[]
C_R^K	number of combinations of R hydrants taken K at a time	[]
d	nominal discharge of the hydrant	[l s ⁻¹]
dH	variation of the head at the upstream end of the elementary scheme of the network	[m]
d_j	discharge for supplying the network downstream the hydrant j	[l s ⁻¹]
dP	minimum cost variation	[ITL]
dY_k	variation of the friction losses in section k	[m]
D	diameter of the pipe	[mm]
D_{c_k}	commercial diameters for section k	[mm]
$(D_{max})_k$	maximum commercial diameter for the section k	[mm]
$(D_{max})_{k,r}$	maximum commercial diameter of the section, k , for the configuration r	[mm]
$(D_{min})_k$	minimum commercial diameter for the section k	[mm]
$(D_{min})_{k,r}$	minimum commercial diameter of the section, k , for the configuration r	[mm]
EH_i	minimum value of the excess head prevailing at all the nodes where the head changes	[m]
f	input frequency of the network (50 Mz standard)	[Mz]
F	set of all unsatisfactory states (failure)	[]
$F(u')$	ratio between $\Psi(u')$ and $\Pi(u')$	[]
F_h	cumulated frequency of the hourly withdrawals during the peak period	[]
FP_{SE}	empirical function indicating the cost variation of the sectors' network, SE, for the variation of its upstream piezometric elevation (Z_{SE})	[]
g	acceleration of gravity	[m s ⁻²]
$H_{j,r}$	head of each hydrant j within the configuration r	[m]
$(H_j)_r$	head of the whole set of hydrants j within the configuration r	[m]

$H_{j,\min}$	minimum head required at the hydrant j	[m]
H_j	head at the hydrant j	[m]
H_{\min}	minimum required head	[m]
H_o	hydrostatic head	[m]
H_{pS}	head at the pumping station	[m]
ITL	Italian lire	[]
J	generic slope of the piezometric line	[m m ⁻¹]
$J_{k,s}$	head losses for unit length of the section k, with the diameter D_s	[m m ⁻¹]
$J_{k,s,r}$	head losses for unit length of the section k, for the discharge of the configuration r, with the diameter D_s	[m m ⁻¹]
k	section identification index	[]
L	generic length of the section	[m]
L_k	length of the section k	[m]
$L_{s,k}$	length of the s th diameter of the section k	[m]
N	number of hydrants simultaneously operating	[]
NAD_k	number of allowable commercial diameters for the section k	[]
NAD_k	number of allowable diameters for the section k	[]
N_p	total population of withdrawn discharges	[]
NQ_i	number of discharges included in the class i	[]
N_{SE}	number of sectors within the district to be optimized	[]
N_{TR}	total number of sections	[]
p	elementary probability of operation of each hydrant	[]
P_C	average cost of the network for the configurations C	[ITL]
$P_{G\lambda}$	conditional probability to change from the state j into the state j+1 during the interval dt	[]
$P_{G\mu}$	conditional probability to change from the state j into the state j-1 during the interval dt	[]
$P_{i,C}$	cost of the network for the configurations i of C	[ITL]
P_k	cost of the section k	[ITL]
P_λ	conditional probability for having an arrival during the time interval (t, t+dt)	[]

P_{μ}	conditional probability for having a departure during the time interval $(t, t + dt)$	[]
P_{NET}	cost of the network	[ITL]
P_q	cumulative probability	[]
P_s	cost per unit length of diameter D_s	[ITL m ⁻¹]
P_{SAT}	conditional probability to have saturation when an opening occurs	[]
q_p	peak continuous flow rate 24/24 hours on the total area	[l s ⁻¹ ha ⁻¹]
q_{pi}	peak continuous flow rate 24/24 hours on the irrigable area	[l s ⁻¹ ha ⁻¹]
q_s	specific continuous discharge	[l s ⁻¹ ha ⁻¹]
\overline{Q}	average discharge withdrawn during the peak period	[l s ⁻¹]
Q	generic discharge	[l s ⁻¹]
Q_{Cl}	Clément discharge at the upstream end of the network	[l s ⁻¹]
$Q_{h,d}$	hourly discharges recorded during the peak period	[l s ⁻¹]
Q_k	discharge in the section k	[l s ⁻¹]
$Q_{k,r}$	discharge flowing in the section k for the configuration r	[l s ⁻¹]
Q_t	discharge withdrawn at a generic instant t at the upstream end of the network	[l s ⁻¹]
Q_{t+t1}	discharge withdrawn at an instant t+t1 at the upstream end of the network	[l s ⁻¹]
r	coefficient of utilization of the network	[]
R	total number of hydrants	[]
R_e	number of Reynolds	[]
RN	random number having uniform distribution function	[]
s_j	numerical indicator of the severity of the state x_j of a system	[]
S	set of all satisfactory states	[]
S_k	series of commercial diameters for each section, k, between $(Dmin)_k$ and $(Dmax)_k$	[]
t'	average operation time of each hydrant during the peak period	[h]
t_{irr}	duration of the opening of the hydrant j	[h]
\overline{T}_f	average sojourn time in the failure states during the period under observation	[h]
T	duration of the peak period	[h]
T'	operating time of the network during the period T	[h]

T_f	time period in which the system is in unsatisfactory state	[h]
u	dimensional coefficient of resistance	[m ⁻¹ s ²]
u	standard normal variable in the 1 st Clément's formula	[]
u'	standard normal variable in the 2 nd Clément's formula	[]
$U(P_q)$	standard normal variable for $P = P_q$	[]
v_{\max}	maximum flow velocity	[m s ⁻¹]
v_{\min}	minimum flow velocity	[m s ⁻¹]
V_d	average daily volume	[m ³]
V_h	average hourly volume	[m ³]
V_T	total average volume withdrawn in the average day of the peak period	[m ³]
$x_{i,s}$	partial length of section k having diameter $D_{k,s}$	[m]
X_t	generic random variable denoting the state of a system at time t	
Y	head losses	[m]
Y^*	value of the head losses in the section k for the largest diameter over its entire length, if the section has two diameters, or the next greater diameter if the section has only one diameter	[m]
Y_k	head losses in the section k	[m]
$Y_{k,r}$	head losses in the section k for the configuration r	[m]
Y_{PS}	head losses in the pumping station	[m]
$(Z_0)_{in}$	initial upstream piezometric elevation	[m a.s.l.]
$(Z_0)_{in,r}$	initial upstream piezometric elevation for the configuration r	[m a.s.l.]
Z_0	available piezometric elevation at the upstream end of the network	[m a.s.l.]
Z_j	piezometric elevation at the hydrant j	[m a.s.l.]
Z_{SE}	upstream piezometric elevation at the upstream end of a sector	[m a.s.l.]
Z_{serb}	upstream piezometric elevation	[m a.s.l.]
ZT_j	land elevation at the node j	[m a.s.l.]
ZT_{PS}	land elevation at the pumping station	[m a.s.l.]
α	reliability of a system	[]
$\Delta H_{j,r}$	relative pressure deficit at the hydrant j in the configuration r	[]

ΔY_i	minimum value of $(Y_{k,i} - Y^*)$	[m]
ΔZ_i	difference between the piezometric elevation at iteration i, $(Z_0)_i$, and the piezometric elevation effectively available at the upstream of the network (Z_0)	[m]
ε	equivalent homogeneous roughness	[mm]
ε_t	discharge tolerance	[l s ⁻¹]
γ	roughness parameter of Bazin	[m ^{0.5}]
λ	constant proportional coefficient	[]
λ_N	constant proportional coefficient for the state N	[]
λ_j	birth coefficient (hydrants opening coefficient)	[]
μ_{exp}	experimental mean value	[l s ⁻¹]
μ_h	average hourly discharges	[l s ⁻¹]
μ_j	death coefficient (hydrants closing coefficient)	[]
μ_{th}	theoretical mean value	[l s ⁻¹]
$\Pi(u')$	cumulative Gaussian probability function	[]
σ^2	variance	
$\Psi(u')$	Gaussian probability distribution function	[]
$\sum_{0 \rightarrow M_j} Y_k$	head losses from the upstream end of the network and the hydrant j along the path M_j	[m]

Chapter 1

On-demand irrigation systems and data necessary for their design

Large distribution irrigation systems have played an important role in the distribution of scarce water resources that otherwise would be accessible to few. Also they allow for a sound water resource management by avoiding the uncontrolled withdrawals from the source (groundwater, rivers, etc). Traditional distribution systems have the common shortcoming that water must be distributed by some rotation criteria that guarantees equal rights to all beneficiaries. The inevitable consequence is that crops cannot receive the water when needed and reduced yields are unavoidable. However, this compromise was necessary to spread the benefits of a scarce resource.

Among the distribution systems, the pressurized systems have been developed during the last decades with considerable advantages with respect to open canals. In fact, they guarantee better services to the users and higher distribution efficiency. Therefore, a greater surface may be irrigated with a fixed quantity of water. They overcome the topographic constraints and make it easier to establish water fees based on volume of water consumed because it is easy to measure the water volume delivered. Consequently, a large quantity of water may be saved since farmers tend to maximize the net income by making an economical balance between costs and profits. Thus, because the volume of water represents an important cost, farmers tend to be efficient with their irrigation. Operation, maintenance and management activities are more technical but easier to control to maintain a good service.

Since farmers are the ones who take risks in their business, they should have water with as much flexibility as possible, i.e., they should have water on-demand.

By definition, in irrigation systems operating on-demand, farmers decide when and how much water to take from the distribution network without informing the system manager. Usually, on-demand delivery scheduling is more common in pressurized irrigation systems, in which the control devices are more reliable than in open canal systems.

The on-demand delivery schedule offers a greater potential profit than other types of irrigation schedules and gives a great flexibility to farmers that can manage water in the best way and according to their needs. Of course, a number of preliminary conditions have to be guaranteed for on-demand irrigation. The first one is an adequate water tariff based on the volume effectively withdrawn by farmers, preferably with increasing rates for increasing water volumes. The delivery devices (hydrants) have to be equipped with flow meter, flow limiter, pressure control and gate valve. The design has to be adequate for conveying the demand discharge during the peak period by guaranteeing the minimum pressure at the hydrants for conducting the on-farm irrigation in an appropriate way.

In fact, one of the most important uncertainties the designer has to face for designing an on-demand irrigation system is the calculation of the discharges flowing into the network. Because farmers control their irrigation, it is not possible to know, a-priori, the number and the position of the hydrants in simultaneous operation. Therefore, a hydrant may be satisfactory, in terms of

minimum required pressure and/or discharge, when it operates within a configuration¹ but not when it operates in another one, depending on its position and on the position of the other hydrants of the configuration. These aspects will be treated in detail in the next chapters of this paper.

For on-demand irrigation, the discharge attributed to each hydrant is much greater than the duty². It means that the duration of irrigation is much shorter than 24 hours. As a result, the probability to have all the hydrants of the network simultaneously operating is very low. Thus, it would not be reasonable to dimension the network for conveying a discharge equal to the sum of the hydrant capacities. These considerations have justified the use of probabilistic approaches for computing the discharges in on-demand irrigation systems.

Important spatial and temporal variability of hydrants operating at the same time occur in such systems in relation to farmers' decision over time depending on the cropping pattern, crops grown, meteorological conditions, on-farm irrigation efficiency and farmers' behaviour. This variability may produce failures related to the design options when conventional optimization techniques are used. Moreover, during the life of the irrigation systems, changes in market trends may lead farmers to large changes in cropping patterns relatively to those envisaged during the design, resulting in water demand changes. Furthermore, continuous technological progress produces notable innovations in irrigation equipment that, together with on-farm methods that can be easily automated, induce farmers to behave in a different way with respect to the design assumptions. In view of the changes in socio-economic conditions of farmers, a change in their working habits over time should not be neglected. Therefore, both designers and managers should have adequate knowledge on the hydraulic behaviour of the system when the conditions of functioning change respect to what has been assumed.

Improving the design and the performance of irrigation systems operating on-demand requires the consideration of the flow regimes during the design process. It requires new criteria to design those systems which are usually designed for only one single peak flow regime. Complementary models for the analysis and the performance criteria need to be formulated to support both the design of new irrigation systems and the analysis of existing ones. In fact the first performance criterion should be to operate satisfactorily within a wide range of possible demand scenarios. For existing irrigation systems, the models for the analysis may help managers in understanding why and where failures occur. In this way, rehabilitation and/or modernization of the system are achieved in an appropriate way.

MAIN CRITERIA TO DESIGN A DISTRIBUTION IRRIGATION SYSTEM

An irrigation system should meet the objectives of productivity which will be attained through the optimization of investment and running costs (Leonce, 1970). A number of parameters have to be set to design the system (Figure 1). These parameters may be classified into environmental parameters and decision parameters. The environmental parameters cannot be modified and have to be taken into account as data for the design area. The latter depend on the designer decisions.

¹ In this paper, each group of hydrants operating at a given instant is called "hydrants configuration". Each hydrant configuration produces a discharge configuration into the network. The term flow regime is also used as synonymous of discharge configuration.

² In this paper the term duty is used to designate the continuous flow required to satisfy the crop demand and losses of the plot (expressed in $l\ s^{-1}$)

The most important environmental parameters are:

- climate conditions
- pedologic conditions
- agricultural structure and land tenure
- socio- economic conditions of farmers
- type and position of the water resource

Information on the climate conditions is required for the computation of the reference evapotranspiration. Rainfall is important for the evaluation of the water volume that may be utilized by the crops without irrigation.

Information on the pedologic conditions of the area under study is important to identify the boundary of the irrigation scheme, the percentage of uncultivated land, the hydrodynamic characteristics of the soil and the related irrigation parameters (infiltration rate, field capacity, wilting point, management allowable deficit, etc.).

The water resources usually represent the limiting factor for an irrigation system. In fact, the available water volume, especially during the peak period, is often lower than the water demand and storage reservoirs are needed in order to satisfy, fully or partially, the demand. Also the location of the water resource respect to the irrigation scheme has to be taken into account because it may lead to expensive conveyance pipes with high head losses.

Finally, the socio-economic conditions of farmers have to be taken into account. They are important both for selecting the most appropriate delivery schedule and the most appropriate on-farm irrigation method.

All the above parameters have great influence on the choice of the possible cropping pattern.

The most important decision parameters are:

- cropping pattern
- satisfaction of crop water requirements (partially or fully)
- on-farm irrigation method
- density of hydrants
- discharge of hydrants
- delivery schedule

The cropping pattern is based on climate data, soil water characteristics, water quality, market conditions and technical level of farmers. The theoretical crop water requirements is derived from the cropping pattern and the climatic conditions.

It is important to establish, through statistical analysis, the frequency that the crop water requirement will be met according to the design climatic conditions. Usually, the requirement should be satisfied in four out of five years. The requirements have to be corrected by the global efficiency of the irrigation system. The computed water volume has to be compared with the available water volume to decide the irrigation area and/or the total or partial satisfaction of the crops in order to obtain the best possible yield.

FIGURE 1
Scheme of the main steps of an irrigation project

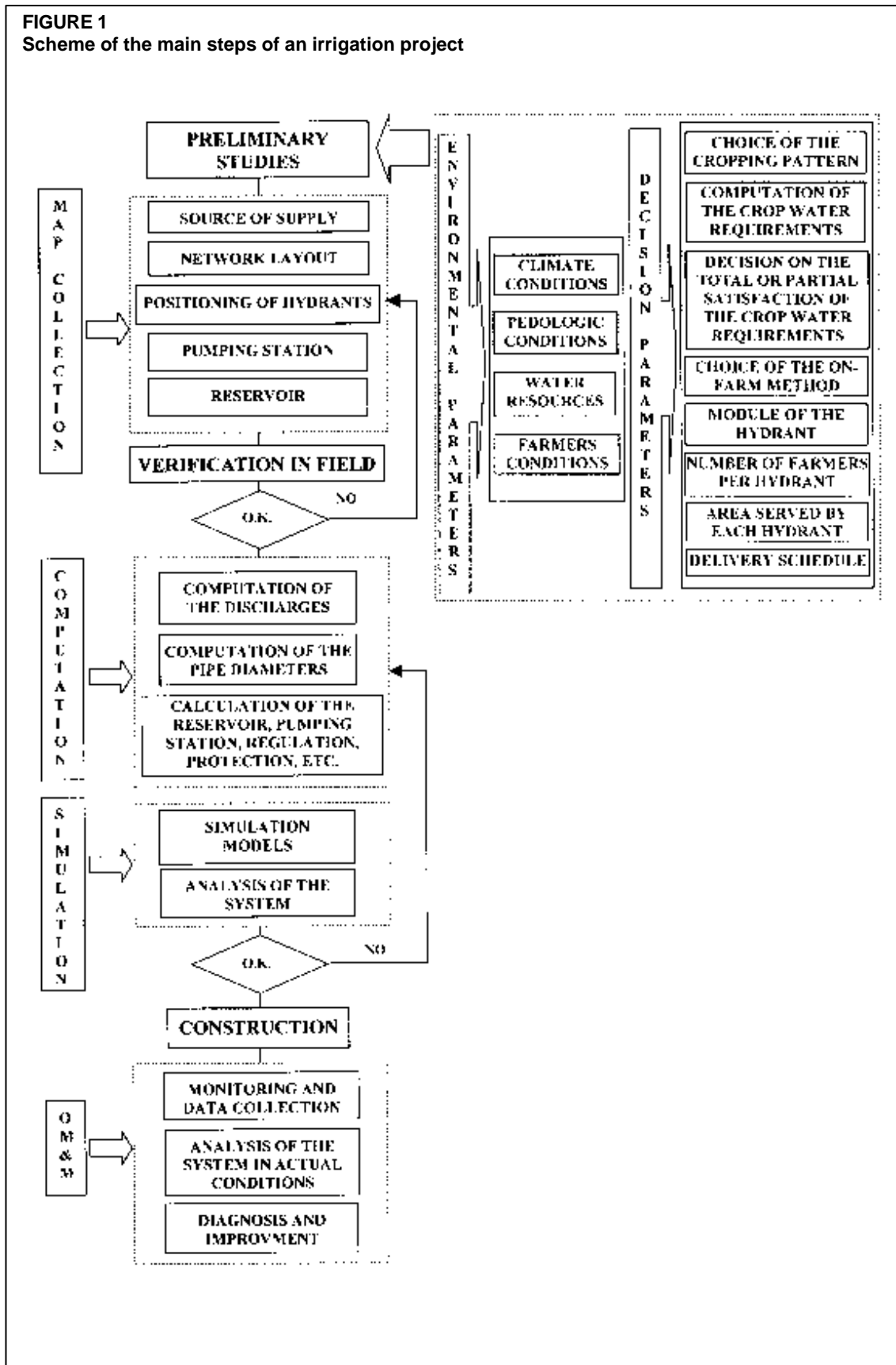

The water requirements should account for the peak discharge. This aspect concerns the pipe size computation and will be treated in detail in this paper.

The designer needs updated maps at an appropriate scale (1:25 000, 1:5 000, 1:2 000) with contour lines, cadastral arrangement of plots and holdings (i.e. the designer should know the area of each plot and the name of the holder). In fact, it may happen that a holder has two or more plots and might be served by only one hydrant located in the most appropriate point. The maps should allow for drawing of the system scheme.

The number of hydrants in an irrigation system is a compromise. A large number improves operation conditions of farmers but it makes for higher installation costs. Usually, for an appropriate density of hydrants it is better to plan no less than one hydrant of 5 l s^{-1} for 2.5 ha and, in irrigation schemes where very small holdings are predominant, no more than three or four farmers per hydrant. These limits will allow a good working conditions of farmers. Also the access to the hydrants should be facilitated. For this reason, in the case of small holdings it is appropriate to locate hydrants along the boundary of the plots. In case of large holdings it may be more appropriate to put hydrants in the middle of the plot in order to reduce the distance between the hydrant and the border of the plot.

The successive steps for designing an irrigation system include defining the network layout and the location of the additional works, like pumping station, upstream reservoir, and equipment for protection and/or regulation, if required. It is important to stress that the above phases are drawn on the maps. Because they are often not updated, field verification is needed in order to avoid passing over new structures that have not been reported on maps.

If everything is done well (usually it never occurs), it is possible to move on the next steps, otherwise adjustments have to be done for one or more of the previous steps (Figure 1).

After the previous analysis, computations of the discharges to be conveyed, the pipe diameters of the network, the additional works, like pumping station, upstream reservoir, and equipment for protection and/or regulation, are performed.

The development process of an irrigation system follows a systematic chronological sequence represented in Figure 2.

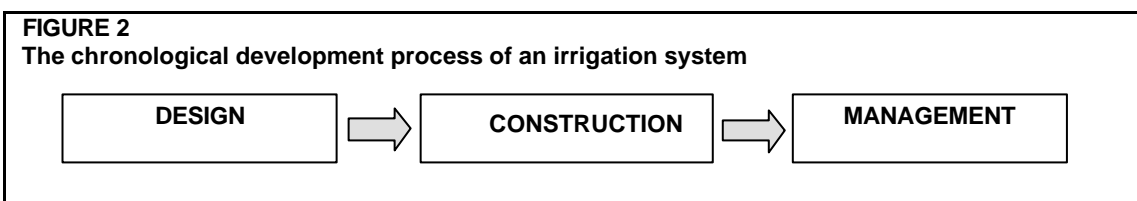

When this process is a “one-way” process, obviously management comes last. However, experience with many existing irrigation schemes has proven that management problems are related to design (Ait Kadi, 1990; Lamaddalena, 1997). This is because the designer does not necessarily have the same concerns as the manager and the user of a system. It appears beneficial to consider the process in Figure 2 as a “whole”, where the three phases are intimately interrelated (Figure 3).

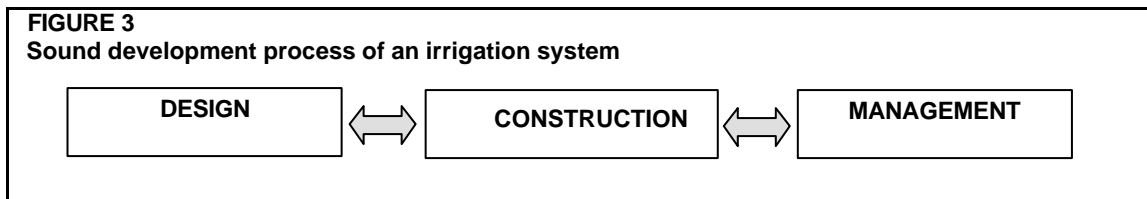

For these reasons, before moving on the construction of the system, models have to be used to simulate different scenarios and possible operation conditions of the system during its life. The simulation models will allow analysis of the system and will identify failures that may occur. In case of failures, the design has to be improved with adequate techniques that will be described in this paper. Then the construction may start.

After the construction, the designer should monitor the system and collect data on operation, maintenance and management phases. It will allow performing the analysis under actual conditions and will allow calibrating, validating and updating existing models, besides formulating new models, too.

Furthermore, management and all the experience gained on the actual irrigation systems should serve as a logical basis for any improvement of future designs.

LAYOUT OF THE PAPER

In chapter 1, the definition of on-demand irrigation systems was formulated as well as the main criteria for their design. In chapter 2, criteria for designing the network layout will be analysed. In chapter 3, two probabilistic approaches for computing the discharges in on-demand irrigation systems are presented as well as a model to generate several random flow regimes. In chapter 4, criteria for computing the optimal pipe size diameters, both in the case of one flow regime and several flow regimes occurring in the network, will be formulated. In chapter 5, models for the analysis and performance criteria are identified in order to support design of irrigation systems which should be able to operate satisfactorily within a wide range of possible demand scenarios. Reliability criteria are also presented in this chapter. Finally, the most important management issues are illustrated in chapter 6.

Throughout the paper, a computer software package, called COPAM (Combined Optimization and Performance Analysis Model), is presented and illustrated. COPAM provides a computer assisted design mode. One or several flow regimes may be generated. The optimization modules give the optimal pipe sizes in the whole network. The performance of the resulting design is then analysed according to performance criteria. Based on this analysis, the designer decides whether or not to proceed with further improvements either by a new optimization of the whole system or through implementation of local solutions (such as using booster pumps or setting time constraints for unsatisfied hydrants).

The synthetic flow chart of COPAM is presented in Figure 4.

FIGURE 4
Synthetic flow chart of COPAM

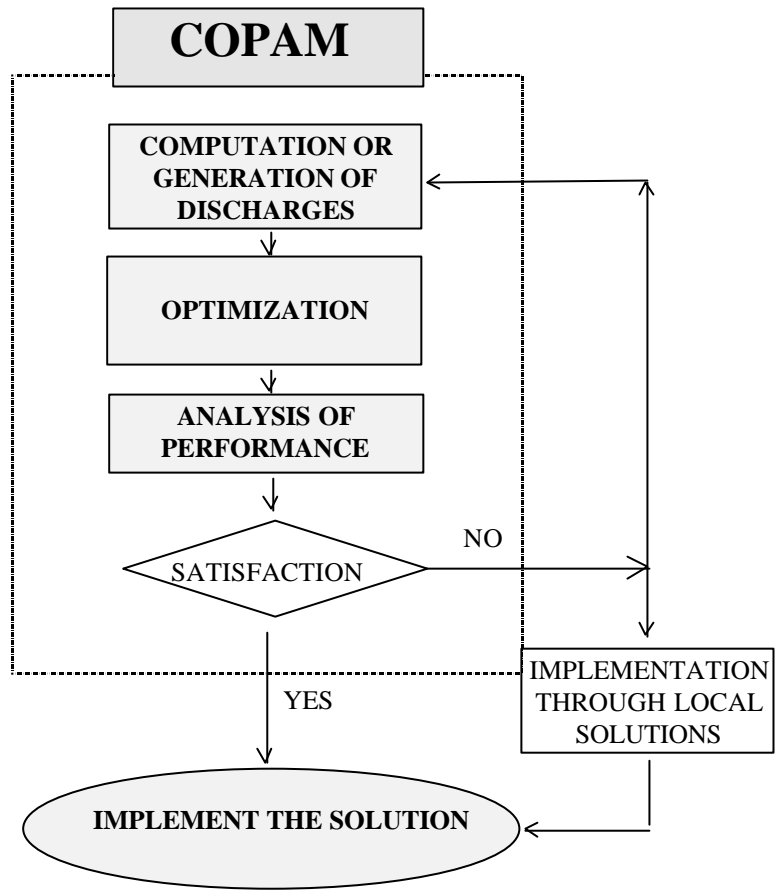

Chapter 2

Network layout¹

STRUCTURE AND LAYOUT OF PRESSURE DISTRIBUTION NETWORKS

Pressure systems consist mainly of buried pipes where water moves under pressure and are therefore relatively free from topographic constraints. The aim of the pipe network is to connect all the hydrants to the source by the most economic network. The source can be a pumping station on a river, a reservoir, a canal or a well delivering water through an elevated reservoir or a pressure vessel. In this publication, only branching networks will be considered since it can be shown that their cost is less than that of looped networks. Loops are only introduced where it becomes necessary to reinforce existing networks or to guarantee the security of supply.

DESIGN OF AN ON-DEMAND IRRIGATION NETWORK

Layout of hydrants

Before commencing the design of the network the location of the hydrants on the irrigated plots has to be defined. The location of the hydrants is a compromise between the wishes of the farmers, each of whom would like a hydrant located in the best possible place with respect to his or her plot, and the desire of the water management authority to keep the number of hydrants to a strict minimum so as to keep down the cost of the collective distribution network.

In order to avoid excessive head losses in the on-farm equipment, the operating range of an individual hydrant does not normally exceed 200 metres in the case of small farms of a few hectares and 500 metres on farms of about ten hectares. The location of hydrants is influenced by the location of the plots. In the case of scattered smallholdings, the hydrants are widely spaced (e.g. at plot boundaries) so as to service up to four (sometimes six) users from the same hydrant. When the holdings are large the hydrant is located preferably at the center of the area.

Layout of branching networks

Principles

On-demand distribution imposes no specific constraints on the network layout. Where the land-ownership structure is heterogeneous, the plan of the hydrants represents an irregular pattern of points, each of which is to be connected to the source of water. For ease of access and to avoid purchase of rights of way, lay the pipes along plot boundaries, roads or tracks. However, since a pipe network is laid in trenches at a depth of about one metre, it is often found advantageous to cut diagonally across properties and thus reduce the length of the pipes and their cost. A method

¹ This chapter has been summarized from FAO Irrigation and Drainage Paper 44. It has been included in this publication for completeness of the treated subject.

of arriving at the optimal network layout is described in the following section. It involves the following three steps in an iterative process:

- "proximity layout" or shortest connection of the hydrants to the source;
- "120° layout" where the proximity layout is shortened by introducing junctions (nodes) other than the hydrants;
- "least cost layout" where the cost is again reduced, this time by shortening the larger diameter pipes which convey the higher flows and lengthening the smaller ones.

The last step implies a knowledge of the pipe diameters. A method of optimizing these diameters is described in Chapter 4.

Fields of application of pipe network optimization

Case of dispersed land tenure pattern

A search for the optimal network layout can lead to substantial returns. An in-depth study (ICID, 1971) of a network serving 1 000 ha showed that a cost reduction of nine percent could be achieved with respect to the initial layout. This cost reduction was obtained essentially in the range of pipes having diameters of 400 mm or more.

In general it may be said that the field of application of network layout optimization mainly concerns the principal elements of the network (pipe diameters of 400 mm and upwards). Elsewhere land tenure and ease of maintenance (accessibility of junctions, etc.) generally outweigh considerations of reduction of pipe costs.

In support of this assertion it is of interest to note that in the case of a 32 000 ha sector, which forms a part of the Bas-Rhône Languedoc (France) irrigation scheme, pipes of 400 mm diameter and above account for less than twenty percent of the total network length. In terms of investment, however, these larger pipes represent nearly sixty percent of the total cost (ICID 1971).

Case of a rectangular pattern of plots

In the case of schemes where the land tenure has been totally redistributed to form a regular checkwork pattern of plots, the pipe network can follow the same general layout with the average plot representing the basic module or unit. The layout of the pipe network is designed so as to be integrated with the other utilities, such as the roads and the drainage system.

OPTIMIZATION OF THE LAYOUT OF BRANCHING NETWORKS

Methodology

The method commonly used (Clément and Galand, 1979) involves three distinct stages:

- 1 - proximity layout
- 2 - 120° layout
- 3 - least-cost layout

Stage 1: Proximity layout

The aim is to connect all hydrants to the source by the shortest path without introducing intermediate junctions here denominated nodes. This may be done by using a suitable adaptation of Kruskal's classic algorithm from the theory of graphs.

If a straight line drawn between hydrants is called a section and any closed circuit a loop, then the algorithm proposed here is the following:

Proceeding in successive steps a section is drawn at each step by selecting a new section of minimum length which does not form a loop with the sections already drawn. The procedure is illustrated in Figure 5 for a small network consisting of six hydrants only.

In the case of an extensive network, the application of this algorithm becomes impractical since the number of sections which have to be determined and compared increases as the square of the number of hydrants: $(n^2 - n)/2$ for n hydrants. For this reason it is usual to use the following adaptation of Sollin's algorithm.

Selecting any hydrant as starting point, a section is drawn to the nearest hydrant thus creating a 2-hydrant sub-network. This sub-network is transformed into a 3-hydrant sub-network by again drawing a section to the nearest hydrant. This in fact is an application of a simple law of proximity, by which a sub-network of $n-1$ hydrants becomes a network of n hydrants by addition to the initial network. This procedure, which considerably reduces the number of sections which have to be compared at each step, is illustrated in Figure 6.

Stage 2: 120° layout

By introducing nodes other than the hydrants themselves, the proximity network defined above can be shortened:

Case of three hydrants

Consider a sub-network of three hydrants A, B, C linked in that order by the proximity layout (Figure 7).

A node M is introduced whose position is such that the sum of the lengths $(MA+MB+MC)$ is minimal.

Let \vec{i} , \vec{j} , \vec{k} be the unit vectors of MA, MB and MC and let dM be the incremental displacement of node M.

When the position of the node is optimal then

$$d(MA + MB + MC) = (\vec{i} + \vec{j} + \vec{k})dM = 0$$

This relation will be satisfied for all displacements dM when

FIGURE 5
Proximity layout: application of Kruskal's algorithm

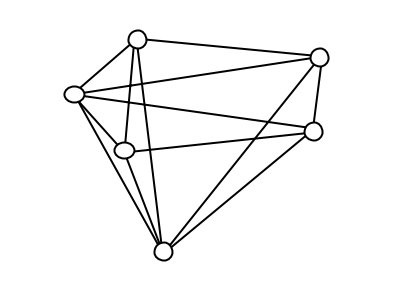

FIGURE 6
Proximity layout: application of Sollin's algorithm

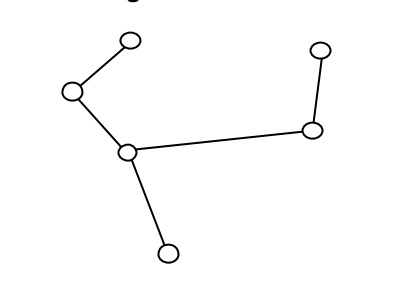
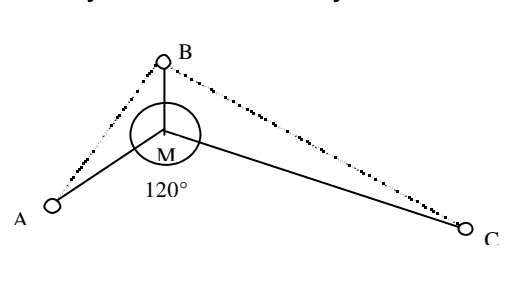

FIGURE 7
120° layout – case of three hydrants



$$\vec{i} + \vec{j} + \vec{k} = 0$$

It follows therefore that the angle between vectors $\vec{i}, \vec{j}, \vec{k}$ is equal to 120° .

The optimal position of the node M can readily be determined by construction with the help of a piece of tracing paper on which are drawn three converging lines subtending angles of 120° . By displacing the tracing paper over the drawing on which the hydrants A, B, C have been disposed, the position of the three convergent lines is adjusted without difficulty and the position of the node determined.

It should be noted that a new node can only exist if the angle \widehat{ABC} is less than 120° . When the angle is greater than 120° , the initial layout ABC cannot be improved by introducing a node and it represents the shortest path. Conversely, it can be seen that the smaller is the angle ABC, the greater will be the benefit obtained by optimizing.

Case of four hydrants

The 120° rule is applied to the case of a four-hydrant network ABCD (Figures 8 and 9).

The layout ABC can be shortened by the introduction of a node M_1 such that sections M_1A , M_1B and M_1C are at 120° to each other.

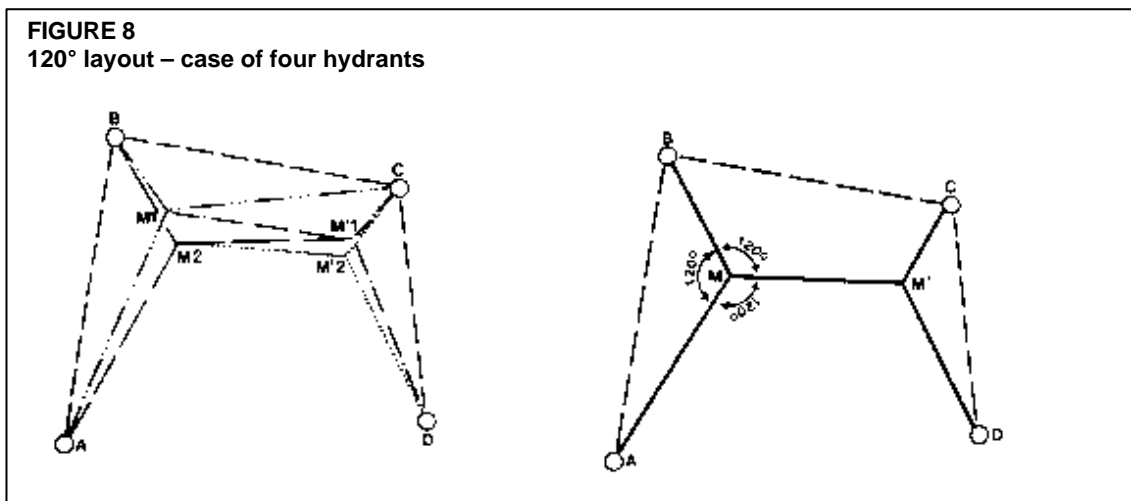

Similarly the layout M_1CD is shortened by the introduction of a node M_1' such that $M_1' M_1$, $M_1' C$ and $M_1' D$ subtend angles of 120° . The angle $\widehat{AM_1M_1'}$ is smaller than 120° and the node M_1 is moved to M_2 by the 120° rule, involving a consequent adjustment of M_1' to M_2' .

The procedure is repeated with the result that M and M' converge until all adjacent sections subtend angles of 120° .

In practice, the positions of M and M' can readily be determined manually with the assistance of two pieces of tracing paper on which lines converging at 120° have been drawn.

A different configuration of the four hydrants such as the one shown in Figure 9, can lead to a layout involving the creation of only one node since the angle \widehat{ABM} is greater than 120° .

Case of n hydrants

The above reasoning can be extended to an initial layout consisting of n hydrants. It can be shown that the resulting optimal layout has the following properties:

- the number of nodes is equal to or less than $n-2$;
- there are not more than three concurrent sections at any node;
- the angles between sections are equal to 120° at nodes having three sections and greater than 120° when there are only two sections.

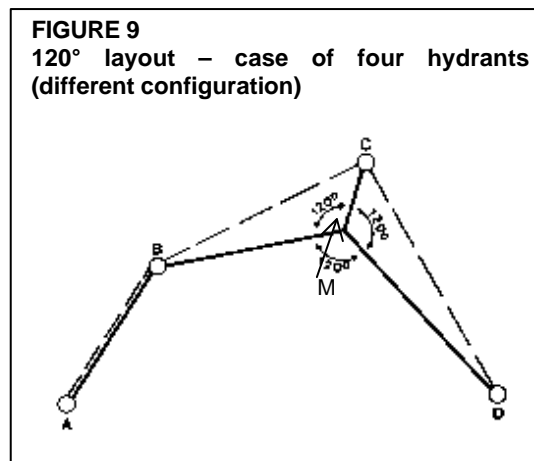

In practice it is impractical to deal manually with the construction of a network consisting of four or five hydrants, involving the introduction of two or three adjacent nodes, even with the help of tracing paper. Several geometric construction procedures have been devised to facilitate such layouts, but these are rather cumbersome and the problem can only be resolved satisfactorily with the assistance of a computer.

It is rarely necessary to create more than two or three consecutive nodes. Also, the benefit gained by optimizing decreases as the number of adjacent sections increases.

Stage 3: Least-cost layout

Although the layout which results from applying the 120° rule represents the shortest path connecting the hydrants, it is not the solution of least cost since no account is taken of pipe sizes. The total cost of the network can further be reduced by shortening the larger diameter pipes which convey higher flows whilst increasing the length of the smaller diameter pipes which convey smaller flows. This will result in a modification of the angles between sections at the nodes. The least-cost layout resembles the 120° layout but the angles joining the pipes are adjusted to take into account the cost of the pipes.

The step which leads from the 120° layout to the least-cost layout can only be taken once the pipe sizes have been optimized. But this condition induces to a loop. In fact, for calculating the pipe sizes of the network, the layout should be already known. A method for the simultaneous computation of optimal pipe size and layout has been developed for particular distribution systems with parallel branches (Ait Kadi, 1986). Two different approaches have been adopted: the linear programming formulation and a special purpose algorithm. Both these two approaches have been applied to a simple example and their reliability and usefulness was demonstrated. Unfortunately, at this time, no commercial software packages are available for applying such method to actual networks.

Applicability of the layout optimization methods

There is no doubt that the 120° layout is an improvement on the initial proximity layout and that the least-cost layout is a further refinement of the 120° layout. It is not certain however that the complete process produces the best result in all cases.

Usually, “rules of thumb” are applied by designers in selecting the best suitable layout and, later, optimization algorithms are applied for computing the pipe sizes. The optimum attained is relative to a given initial layout of which the proximity layout is only the shortest path variant. It

could be that a more economic solution is possible by starting with a different initial layout, differing from that which results from proximity considerations, but which takes into account hydraulic constraints.

In practice, by programming the methods described above for computer treatment, several initial layouts of the network can be tested. The first of these should be the proximity layout. The others can be defined empirically by the designer, on the basis of the information available (elevation of the hydrants and distance from the source) which enables potentially problematic hydrants to be identified. By a series of iterations it is possible to define a "good" solution, if not the theoretical optimum. Furthermore, it should be noted that the above estimates are based on the cost of engineering works only. They do not include the purchase of land, right-of-way and/or compensation for damage to crops which might occur during construction, all of which would affect and increase the cost of the network and might induce to modify the optimal layout.

Chapter 3

Computation of flows for on-demand irrigation systems

One of the most important problems for an on-demand irrigation system designer is the calculation of the discharges flowing into the network. Such discharges strongly vary over time depending on the cropping pattern, meteorological conditions, on-farm irrigation efficiency and farmers' behaviour.

In this paper, each group of hydrants operating at a given instant is called "hydrants' configuration". Each hydrant's configuration produces a discharge configuration (or flow regime) into the network. The term "node" includes both hydrants and junctions of two pipes, whereas the term "section" is used to describe the pipe connecting any two nodes.

The design capacity is usually determined considering short-term peak demand and considering an average cropping pattern for the whole system. But, the individual cropping pattern may differ from the designed one, and the irrigation system may be either undersized or oversized.

In view of the difficulty of this problem, empirical methods have been used. For example, the US Bureau of Reclamation (1967) recommends solving each case on individual basis and gives only general indications like: the maximum demand may generally be estimated at 125-150% of the average demand. Systems operating for a 12-month season may require a capacity large enough to carry from 10 to 15% of the total annual demand in the peak month. Those operating for a 7-month season may require a capacity large enough to carry from 20 to 25% of the total annual demand during the peak month. However, the actual maximum demand should be determined by detailed analysis of individual projects.

The advent of on-demand, large-scale irrigation systems in the early 1960s in France fostered the development of statistical models to compute the design flows. Examples of such models are the first and the second Clément formula (1966). But only the first demand formula has been widely used because of its simplicity.

Although these models are theoretically sound, the assumptions governing the determination of their parameters do not take into account the actual functioning of an irrigation system. In view of these limitations a number of researchers tackled the problem by simulating irrigation strategies. As an example, Maidment and Hutchinson (1983) modeled the demand pattern over a large irrigation area taking into account the size of irrigated area, the soil type, the cropping pattern, the irrigation strategy and the weather variation. However, they had to average out the demand hydrograph over time to avoid unrealistic very high water demand one day and very low the next.

Recently other approaches have been developed combining simulation of irrigation strategies, based on the soil water balance, and statistical models (Abdellaoui, 1986; Walker *et al.*, 1995; Teixeira *et al.*, 1995). The result of these methods is a single distribution of one design flow for

each pipe section of the network. They will be referred to in the following as One Flow Regime Models (OFRM).

OFRM do not actually take into account the hydraulic functioning in an on-demand collective irrigation network. Indeed, in such systems there is occurrence of several flow regimes according to the spatial distribution of the hydrants that are simultaneously in operation. Therefore, improving the design and the performance of an irrigation system operating on-demand requires consideration of these flow regimes in the design process. The new approach, called Several Flow Regimes Models (SFRM), is based on this concept. In this chapter OFRM will be reviewed before presenting the process of generating flow regimes for the SFRM.

ONE FLOW REGIME MODELS (OFRM)

Statistical models: the Clément models

One study that deals explicitly with calculation of pressurized irrigation systems capacity for on-demand operation is the work of Clément (1966). Two different models were proposed. One (called the first Clément model) is based on a probabilistic approach where, within a population of R hydrants, the number of hydrants being open simultaneously is considered to follow a binomial distribution. The other (called the second Clément model) is based on simulating the irrigation process as a birth and death process in which, at a given state j (j hydrants open), the average rate of birth is proportional to $(R-j)$ and the average rate of death is proportional to j . The Clément models, although based on a theory, were extensively used for designing sprinkler irrigation systems in France, Italy, Morocco and Tunisia.

The first Clément model

Background equations

In on-demand irrigation systems, the nominal discharge of the hydrants (d) is selected much higher than the duty, D (the duty is the flow based on peak period water requirement on a 24-hour basis: $D=q_s A_p$, where q_s is the continuous specific discharge and A_p is the area of the plot irrigated by the hydrant). It allows farmers to irrigate for a duration lower than 24 hours. This condition implies that the event to find all the hydrants simultaneously operating has very low probability. Thus, it is not reasonable to calculate the irrigation network by adding the discharges delivered at all the hydrants simultaneously. Consequently, probabilistic approaches for computing the discharges into the sections of an on-demand collective network have been widely used in the past and are still used actually.

The most utilized is the probabilistic approach proposed by Clément (1966) and it is summarized hereafter.

Let q_s be the specific continuous discharge, 24 hours per day ($l s^{-1} ha^{-1}$), A is the irrigated area (ha), R the total number of hydrants, d the nominal discharge of each hydrant ($l s^{-1}$), T the duration of the peak period (h), T' the operating time of the network (h) during the period T , r the coefficient of utilization of the network (defined as the ratio T'/T). The average operation time t' of each hydrant during the peak period (h) is then

$$t' = \left(\frac{q_s A T}{R} \right) / d \quad (1)$$

The elementary probability, p , of operation of each hydrant is defined as

$$p = \frac{t' - t}{T - rT} = \frac{q_s A T}{R d r T} \quad (2)$$

thus,

$$p = \frac{q_s A}{r R d} \quad (3)$$

Therefore, for a population of R homogeneous hydrants, the probability of finding one hydrant open is p , while $(1 - p)$ is the probability to find it closed.

The number of operating hydrants is considered a random variable having a binomial distribution with mean

$$\mu = R p \quad (4)$$

and variance

$$\sigma^2 = R p (1-p) \quad (5)$$

Therefore, the cumulative probability, P_q , that among the R hydrants there will be a maximum of N hydrants simultaneously operating is:

$$P_q = \sum_{K=0}^N C_R^K p^K (1-p)^{(R-K)} \quad (6)$$

where:

$$C_R^K = \frac{R!}{K!(R-K)!} \quad (7)$$

is the number of combinations of R hydrants taken K at a time. When R is sufficiently large ($R > 10$) and $p > 0.2-0.3$, the binomial distribution approximates the Laplace-Gauss normal distribution whose cumulative probability (P_q) for having a maximum of x hydrants simultaneously operating (with $-\infty < x < N$) is:

$$P_q = \frac{1}{\sqrt{2p}} \int_{-\infty}^{U(P_q)} e^{-\frac{u^2}{2}} du \quad (8)$$

where $U(P_q)$ is the standard normal variable corresponding to the probability P_q , and u is the standard normal deviate given by:

$$u = \frac{x - R p}{\sqrt{R p (1-p)}} \quad (9)$$

The integral (8) is solved developing in series the exponential function $e^{-\frac{u^2}{2}}$. The solutions of this integral have been tabulated (see Table 1) and so, according to a prefixed value P_q , it is possible to determine the corresponding value $U(P_q)$.

Knowing $U(P_q)$, it is possible to calculate the number of hydrants simultaneously operating, N , through the relationship (9). In fact, for $u = U(P_q)$ we have:

$$N = R p + U(P_q) \sqrt{R p (1-p)} \quad (10)$$

that is the first formula of Clément.

Considering hydrants with the same discharge, the total discharge downstream a generic section k is given by:

$$Q_k = R p d + U(P_q) \sqrt{R p (1-p) d^2} \quad (11)$$

and, for different discharges of hydrants (d_i), where I is the hydrant class number

$$Q_k = \sum_i R_i p_i d_i + U(P_q) \sqrt{\sum_i R_i p_i (1-p_i) d_i^2} \quad (12)$$

The first Clément model is based on three major hypotheses that limit its applicability (CTGREF, 1974; CTGREF, 1977; Lamaddalena and Ciollaro, 1993).

- The first hypothesis concerns the parameter r . It is defined by Clément as coefficient of utilization of the system in the sense that, during the design phase, the duration of the day for irrigation, within the peak period, is considered shorter than 24 hours. This parameter, defined at the network level in an irrigation system operating on-demand, should have a value equal to one because these systems may have to work 24 hours per day. In practice, the parameter r should correspond to the operating time of each hydrant and, therefore, it is not correct to use it for the global design of the system. Nevertheless, from a conceptual point of view, it may be considered as a parameter which helps adjusting the theoretical formulation to a homogeneous population of discharges, withdrawn in the field, appropriately chosen through a statistical approach. It must be pointed out that the Clément model, like all other models, only offers a schematic representation of an actual network. Therefore, it must be adjusted or calibrated by introducing field data relative to existing networks. In particular, values of the parameter r should be, whenever possible, selected for homogeneous regions and for particular crops. An example of the field Clément model calibration, for an Italian irrigation network, is reported in Annex 1.
- The second hypothesis concerns the elementary probability of opening each hydrant. It refers to an estimation of the average operating time of each hydrant. But, the probability to find a hydrant working at a given time t depends on its state at the previous time $t-1$. In order to justify the binomial law, this probability should characterize a series of events such that when the farmer opens his hydrant at a time t , he would close it after a laps of time dt , and he decides to re-open or to leave it closed at a successive time $t+dt$, and so on. This is not real because a farmer opens his hydrant and leaves it in the same state for a large number of laps of time dt . Moreover, the elementary probability varies during the day according to the farmer's behaviour.
- The third hypothesis considers the independence of the hydrants and their random operation during the peak period. This hypothesis might seem justified because the farmers should behave autonomously and not according to the operation of the neighbour farmers. Nevertheless, the rhythm of nights and days and the similitude of the crops within an irrigation district condition the farmer's behaviour, so that this hypothesis is not fully reliable.

The importance of the r coefficient is stressed also in Figure 10. In this figure two parameters are defined: the elasticity of the network, e_r (Clément and Galand, 1979):

$$e_r = \frac{Q_{Cl}}{q_s A} \quad (13)$$

and the average elasticity of the hydrants (called also farmers "degree of freedom"), e_h ,

TABLE 1
Standard normal cumulative distribution function

P_q	$U(P_q)$
0.90	1.285
0.91	1.345
0.92	1.405
0.93	1.475
0.94	1.555
0.95	1.645
0.96	1.755
0.97	1.885
0.98	2.055
0.99	2.324

$$e_h = \frac{R d}{(q_s A)} \quad (14)$$

The ratio e_R is a measure of the over-capacity of the network and is a characteristic of on-demand operation. The ratio e_h defines the freedom afforded to farmers to organize their irrigation.

The values of e_R refer to a network designed to supply equal flows at all hydrants. When the hydrant design flows are unequal, the values of the ratio are slightly greater. Nevertheless, whether the hydrants are homogeneous or not, taking into account the probability of the demand being spread results in a network peak design flow which is very much smaller than that which would be obtained by summing the flows at all hydrants.

The degree of freedom that is to be afforded to farmers should be selected according to criteria such as size and dispersion of plots, availability of labor, type of on-farm equipment, frequency of irrigation. Hydrants with capacities of one and a half to twice the value of the duty correspond to the lowest feasible degree of freedom. With smaller values, the probability of an hydrant being open becomes too great for the demand model to apply. Conversely, hydrant capacities should not exceed six to eight times the value of the duty. This corresponds to a very high degree of freedom.

Figure 10 illustrates the variation of the elasticity of the network, e_R , versus the total number of hydrants, R , for different values of the elasticity of the hydrants, e_h . The curves have been drawn for $U(P_q)=1.645$. Considering a value of elasticity at the hydrant $e_h = 4.5$, for a network having $R=100$ hydrants, the elasticity of the network e_R varies from about 1.43 (corresponding to $r = 0.9$) to about 2.03 (corresponding to $r = 0.6$). It means that the upstream discharge in an on-demand network (from Eq. 13):

$$Q_{cl} = e_R q_s A \quad (15)$$

may increase about 45% if a coefficient $r=0.6$ is chosen instead of a coefficient $r=0.9$.

Furthermore, from Figure 10 it can be seen that, for on-demand systems, the ratio of the peak flow in the network to the assumed continuous flow (elasticity of the network) increases as the number of hydrants decreases. With hydrant capacities two to four times greater than the duty, by selecting $r=0.9$ the peak flow in a network having 100 hydrants is only 27 to 40 percent greater than the continuous flow; while by selecting $r=0.6$ the peak flow in a network having 100 hydrants is 79 to 98 percent greater than the continuous flow. It means that the coefficient r has much more influence on the design capacity of the network respect to the elasticity of the hydrants. Therefore, in order to give more freedom to farmers, it is more appropriate to select higher hydrant elasticity.

The values selected for the parameter r normally lie between $16/24$ ($r=0.67$) and $22/24$ ($r=0.93$). The performance analysis of existing networks is the most reliable approach for selecting the coefficient r best suited to a given irrigation context.

The parameter $U(P_q)$ defines the "quality of operation" of the network; it normally has a values ranging from 0.99 to 0.95. It is hardly possible to go below a value of 0.95. A significant reduction of this parameter beyond these values can lead to the occurrence of unacceptable failures to satisfy the demand in certain parts of the network (Galand *et al.*, 1975).

In view of the hypotheses made when formulating the on-demand model it is recommended that a deterministic approach be adopted at the extremities of the network by cumulating the flows at the hydrants when their number falls below a certain value which, in practice, lies between four and ten.

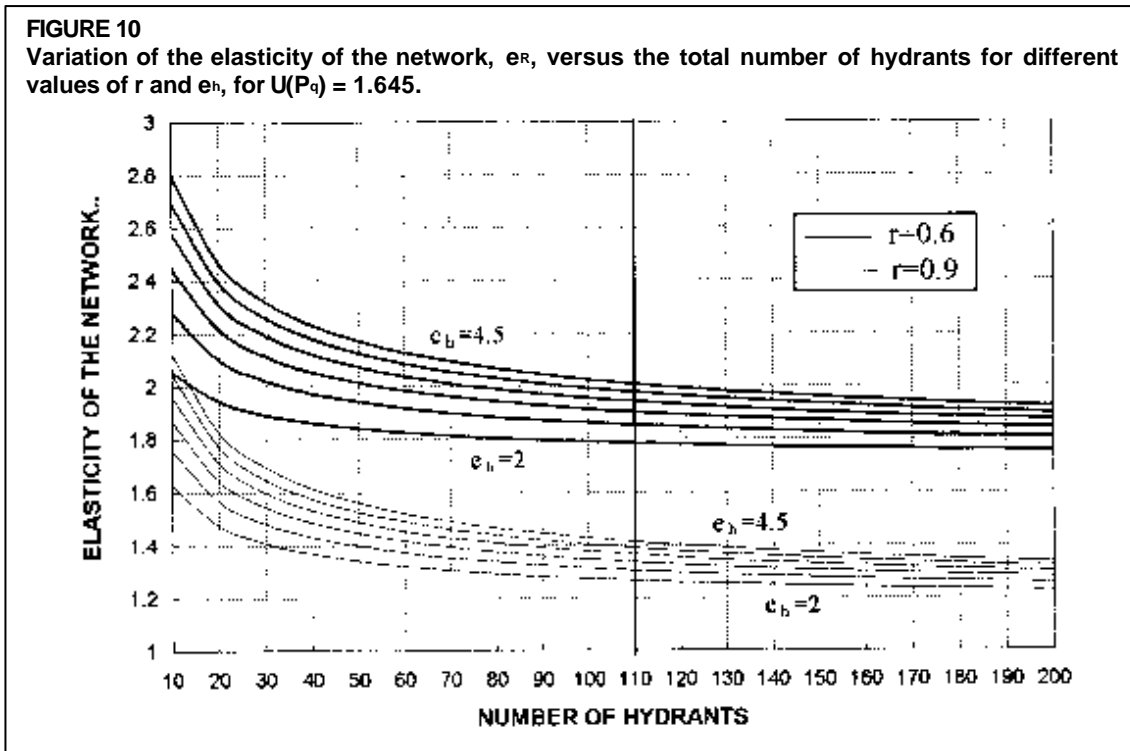

In certain cases it may happen that the calculated discharge of a section serving five or six hydrants is less than that of the downstream section serving four hydrants whose flows have been summed. In this case the discharge in the upstream section will be equal the discharge in the downstream section.

Determination of the specific continuous discharge

In order to apply the above methodology it is necessary to know the value of the specific continuous discharge, q_s ($l\ s^{-1}\ ha^{-1}$) in the network downstream of the section under consideration. Its value can readily be determined when:

- The cropping pattern is identical throughout the area. If this is so the specific continuous discharge, q_s ($l\ s^{-1}\ ha^{-1}$), estimated by giving due weight to each of the crops, holds good for every farm and all branches of the network under consideration.
- The cropping intensity is identical throughout the area. When this is so, the ratio between the net irrigated area and the gross area also holds good for every holding and all parts of the network under study.

A number of computer packages are available for such a computation (CROPWAT, ISAREG, etc.), as well as an extensive literature. Therefore, the reader is referred to them for its calculation.

Discharge at the hydrants

Although a farmer supplied by an on-demand system is free to use his hydrant at any time, a physical constraint is nevertheless imposed as regards the maximum flow he can draw. This is achieved by fitting the hydrant with a flow regulator (flow limiter). The discharge attributed to each hydrant is defined according to the size and crop water requirements of the plot. It is

always greater than the duty so as to give the farmer a certain degree of freedom in the management of the irrigation.

The ratio between the discharge attributed to each hydrant and the duty is a measure of the "degree of freedom" which a farmer has to manage irrigation. The wide variety of agronomic situations is reflected by the wide range of the value of the degree of freedom found in practice (FAO-44, 1990):

- High degree of freedom: family holdings with limited labour, low crop water requirements, small or scattered plots, low investment level in on-farm equipment;
- Low degree of freedom: large size plots, large scale farming, abundant labour, high investment level in on-farm equipment.

Since the maximum flow at hydrants is fixed by flow regulators it is usual to opt for a standard range of flows. Such ranges vary from country to country.

In southeastern France, for instance, a range of six hydrants has been standardized, corresponding to the following discharges:

Class of hydrant	0	1	2	3	4	5
Discharge (l s ⁻¹)	2.1	4.2	8.3	13.9	20.8	27.8

In Italy the range of hydrants corresponds to the following discharges:

Class of hydrant	0	1	2	3	4	5
Discharge (l s ⁻¹)	2.5	5	10	15	20	25

In Box 1, an example of the Clément formula is worked out and the results are shown in Table 2 (generated by COPAM).

TABLE 2

Discharges flowing into each section of the network under study (output of the COPAM package: computation with the first Clément model)

Section Number	Initial Node	Final Node	Number of Hydrants	Area (ha)	1st Clément discharge (l/s)
1	0	1	19	57.00	60.00
2	1	2	18	54.00	60.00
3	2	3	17	51.00	50.00
4	3	4	16	48.00	50.00
5	4	5	15	45.00	50.00
6	5	6	14	42.00	50.00
7	6	7	11	33.00	40.00
8	7	8	8	24.00	40.00
9	8	9	7	21.00	40.00
10	9	10	6	18.00	40.00
11	10	11	5	15.00	40.00
12	11	12	5	15.00	40.00
13	12	13	4	12.00	40.00
14	13	14	3	9.00	30.00
15	14	15	2	6.00	20.00
16	15	16	1	3.00	10.00
17	7	17	3	9.00	30.00
18	17	18	3	9.00	30.00
19	18	19	2	6.00	20.00
20	19	20	1	3.00	10.00
21	6	21	3	9.00	30.00
22	21	22	2	6.00	20.00
23	22	23	1	3.00	10.00
24	8	24	1	3.00	10.00

BOX 1: APPLICATION OF THE FIRST CLÉMENT MODEL FOR THE COMPUTATION OF FLOWS IN AN ON-DEMAND NETWORK

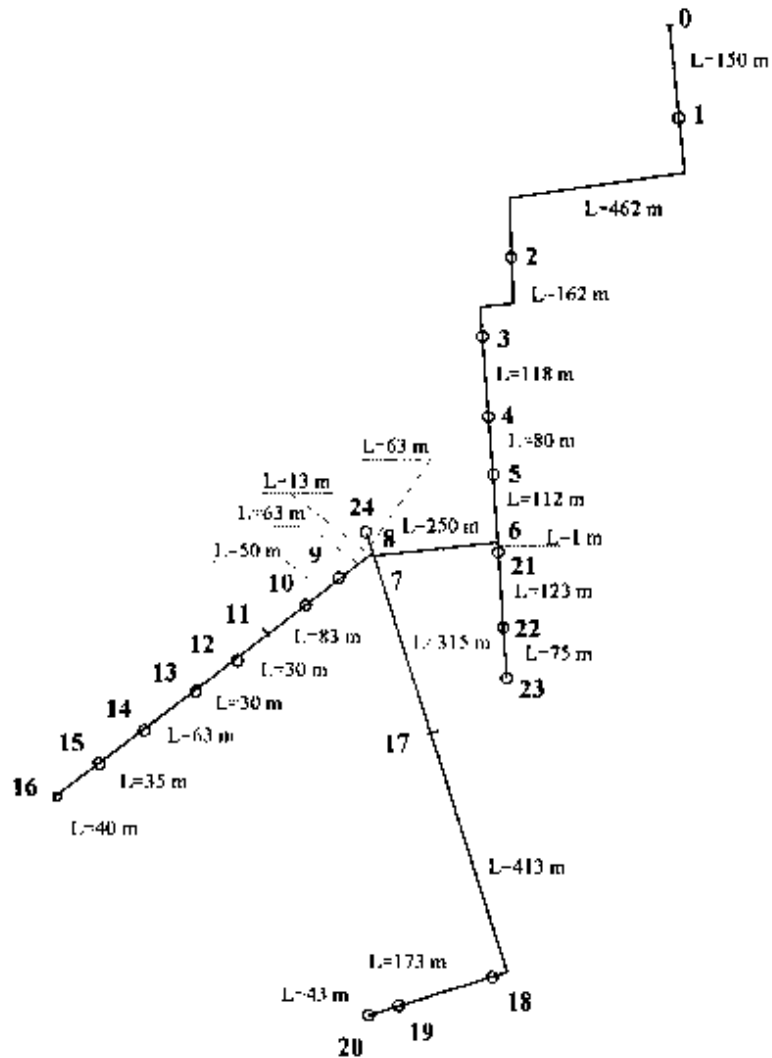

Data:

q_s = specific continuous discharge (24/24 hours) = $0.327 \text{ l s}^{-1} \text{ ha}^{-1}$

A_p = area of the plot to be irrigated = 3 ha

A = total irrigable area = $3 \cdot 19 = 57 \text{ ha}$

d = nominal discharge of the hydrants = 10 l s^{-1}

$U(P_q)$ = operation quality = 1.645

r = use coefficient = 0.667

R = total number of hydrants = 19

N_{ba} = minimum number of hydrants in simultaneous operation = 4

BOX 1 Cont'd

$$p = \text{elementary probability} = \frac{q_s A}{rRd} = \frac{0.327 \cdot 57}{0.667 \cdot 19 \cdot 10} = 0.147$$

1) Number of hydrants simultaneously operating downstream the section 0-1:

$$N_{0-1} = R_{p+U}(P_q) \sqrt{R_p(1-p)} = 19 \cdot 0.147 + 1.645 \sqrt{19 \cdot 0.147 \cdot (1-0.147)} = 5.33$$

We assume $N_{0-1} = 6$ ⁽¹⁾

The design discharge downstream the section 0-1 is:

$$Q_{0-1} = N_{0-1} \cdot d = 6 \cdot 10 = 60 \text{ l s}^{-1}$$

2) Number of hydrants in simultaneous operation downstream the section 1-2:

$$N_{1-2} = R_{1-2} p + U(P_q) \sqrt{R_{1-2} p(1-p)} = 18 \cdot 0.147 + 1.645 \sqrt{18 \cdot 0.147 \cdot (1-0.147)} = 6.11$$

We assume $N_{1-2} = 6$

The design discharge downstream the section 1-2 is:

$$Q_{1-2} = N_{1-2} \cdot d = 6 \cdot 10 = 60 \text{ l s}^{-1}$$

3) Number of hydrants in simultaneous operation downstream the section 2-3:

$$N_{2-3} = R_{2-3} p + U(P_q) \sqrt{R_{2-3} p(1-p)} = 17 \cdot 0.147 + 1.645 \sqrt{17 \cdot 0.147 \cdot (1-0.147)} = 4.90$$

We assume $N_{2-3} = 5$

The design discharge downstream the section 2-3 is:

$$Q_{2-3} = N_{2-3} \cdot d = 5 \cdot 10 = 50 \text{ l s}^{-1}$$

and so on for the calculation of the discharges in the other sections.

In order to facilitate the calculation of large networks, a computer software program called COPAM (Combined Optimization and Performance Analysis Model) has been developed by Lamaddalena (1997). This software (enclosed) has several options that will be explained in this paper.

All the computer programs for computation of irrigation systems require detailed information on the pipe network transporting water from the source to the demand points (hydrants). In the following section some general information on the use of COPAM, as well as the installation of the program and the preparation of the input data files, are presented.

Installation of COPAM

Basic Windows knowledge is required for installing the COPAM Package.

Create an appropriate directory in the hard disk (it can be called "Copam"),

Insert the install disk in the appropriate drive,

Copy all files from the install disk to the directory previously created (e.g. Copam). Verify that the "*.dll" files have been copied,

From Windows Explorer, open the directory Copam and create a shortcut on the desktop for the file (icon) “copam.exe”,

Click the icon label once to change the name. It is suggested to call it COPAM (Figure 11).

Starting COPAM

Double click on the COPAM icon. Figure 12 will occur for few seconds:

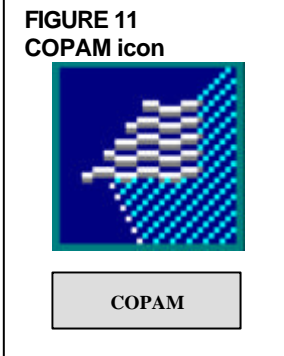
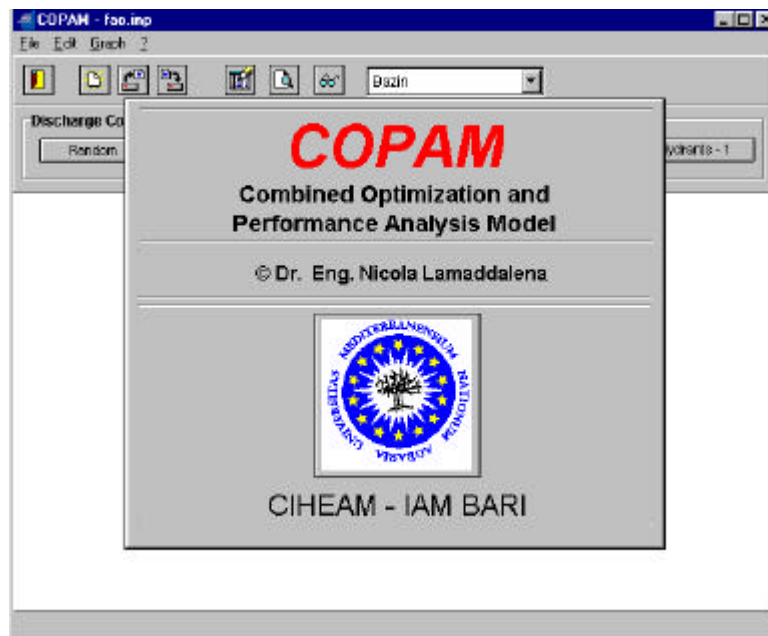

FIGURE 12
First screen of the COPAM package



Then Figure 13 will appear.

Three different sets of programs are available in the COPAM package:

- Discharges computation
- Pipe size computation
- Analysis

Two programs are available under the set “Discharges computation”: Clément and Random. One program is available under the set “Pipe size computation”: optimization. Two programs are available under the set “Analyses”: Configurations and Hydrants. For all the above software, the basic input file is the same and it is explained below.

FIGURE 13
Layout of the COPAM package

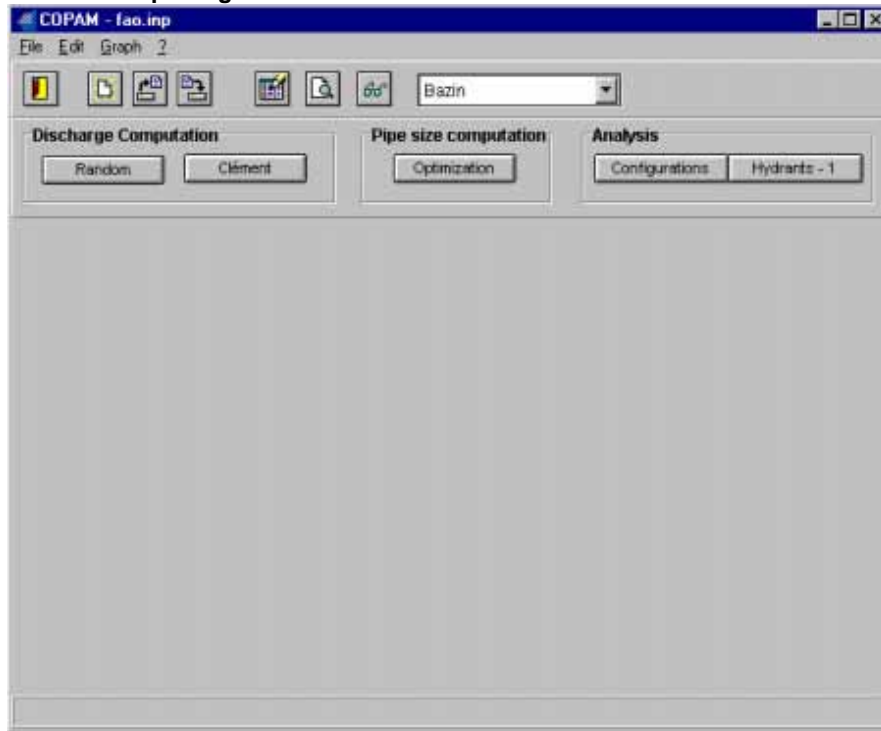
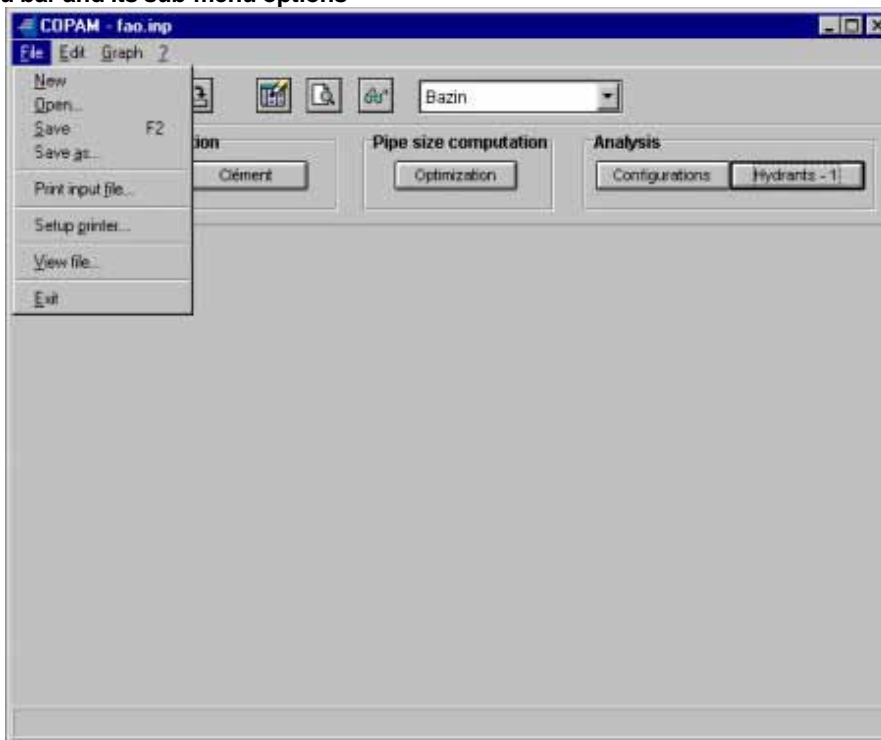

FIGURE 14
File menu bar and its sub-menu options



Preparation of the input file

The line of words beginning “File” is a menu bar. When you click on any of the words with your mouse, a sub-menu will drop down. For example, if you click on the File menu, you will see the sub-menu in Figure 14.

Different options are available in the File menu: New, Open, Save, Save as, Print input file, Setup printer, View file, Exit. All these options are familiar for windows users.

When you want to create a new file, the option “New” is clicked. Then the menu bar “Edit” is selected and the sub-menu in Figure 15 will drop down.

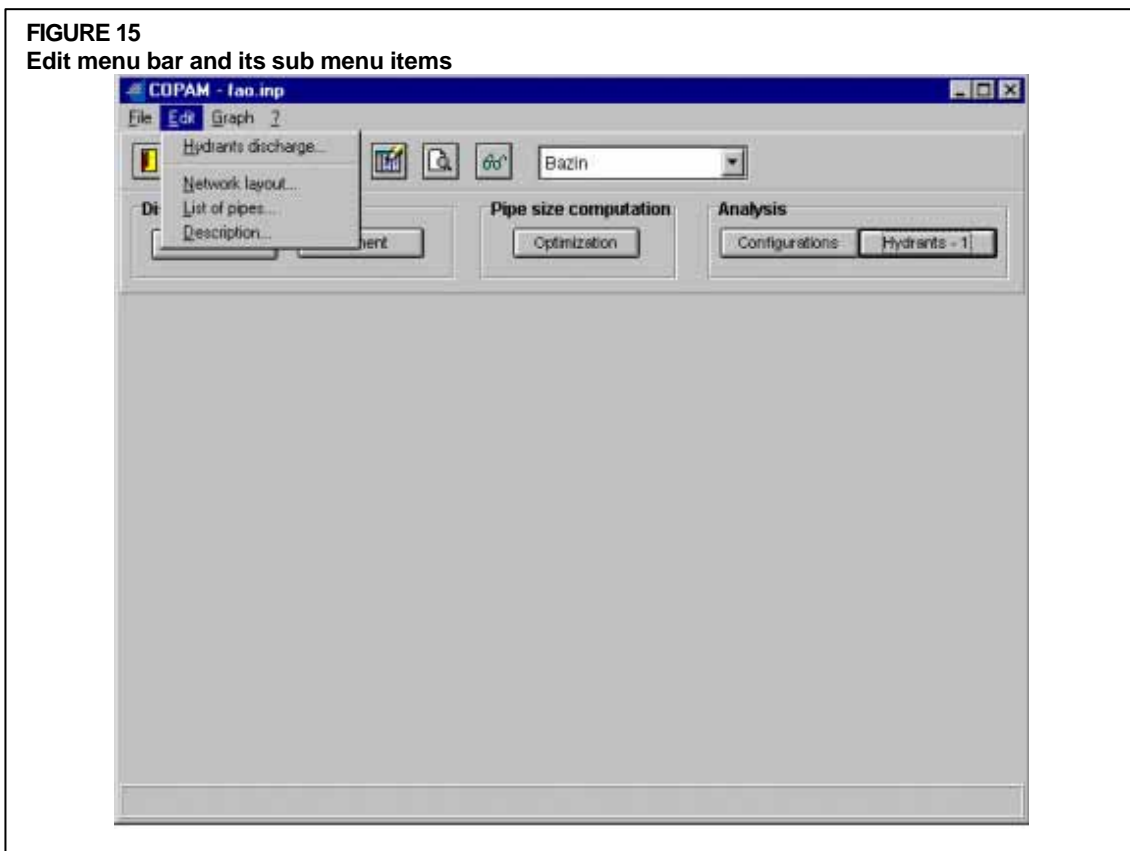

By clicking on each option, the input data may be inserted using the Edit menu. It is strongly recommended to prepare the input data before entering in the program.

First select the sub-menu “Edit/Hydrants Discharge” by clicking on it. Figure 16 will appear and the list of the nominal discharges of the hydrants is inserted in the appropriate edit box. The list of hydrants discharge is introduced in an increasing order and the user should enter any standard values of discharge selected for the project, as used in the respective country.

The command “OK” will close the option and store the information.

By clicking on the option “Network layout”, input data are inserted in the sub-menu “Edit/network layout”.

FIGURE 16
Sub menu Edit/Hydrants discharge

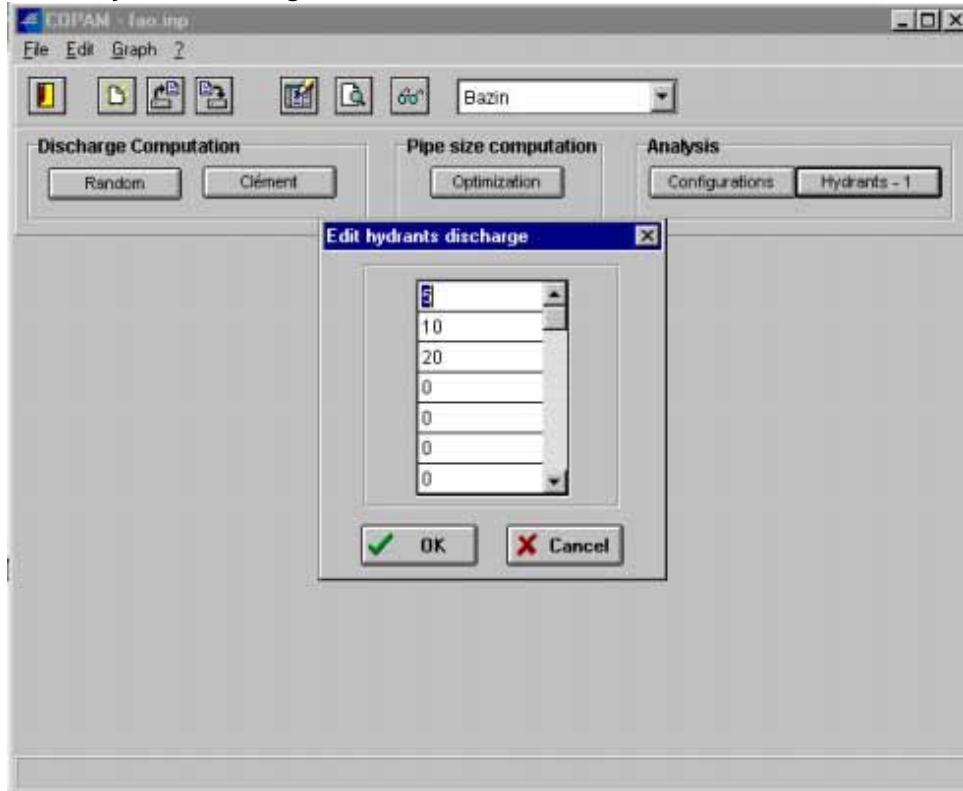

It is assumed the network is of the branching type. Each node (hydrants and/or linking of sections) is positioned by a number. The node numbering is extremely important for the correct execution of the program. It has to be allocated as follows:

- The upstream node (source) must have number 0
- The other nodes are numbered consecutively, from upstream to downstream. Any node may be jumped.
- The number of the section is equal to the number of its downstream node.
- All terminal nodes of the branches must have a hydrant.
- No more than two sections may be derived by an upstream node. If so, an imaginary section with minimum length (i.e.: $l_{\min} = 1$ m) must be created and an additional node must be considered. This node must have a sequential number.
- No hydrants may be located in a node with three sections joined. If so, an additional node with a sequential number must be added.
- If hydrants with two or more outlets exist in the network, one number for each outlet needs to be allocated by creating an imaginary section with minimum length.

When the numbering has been completed, the following information has to be entered in the “Edit/Network layout”:

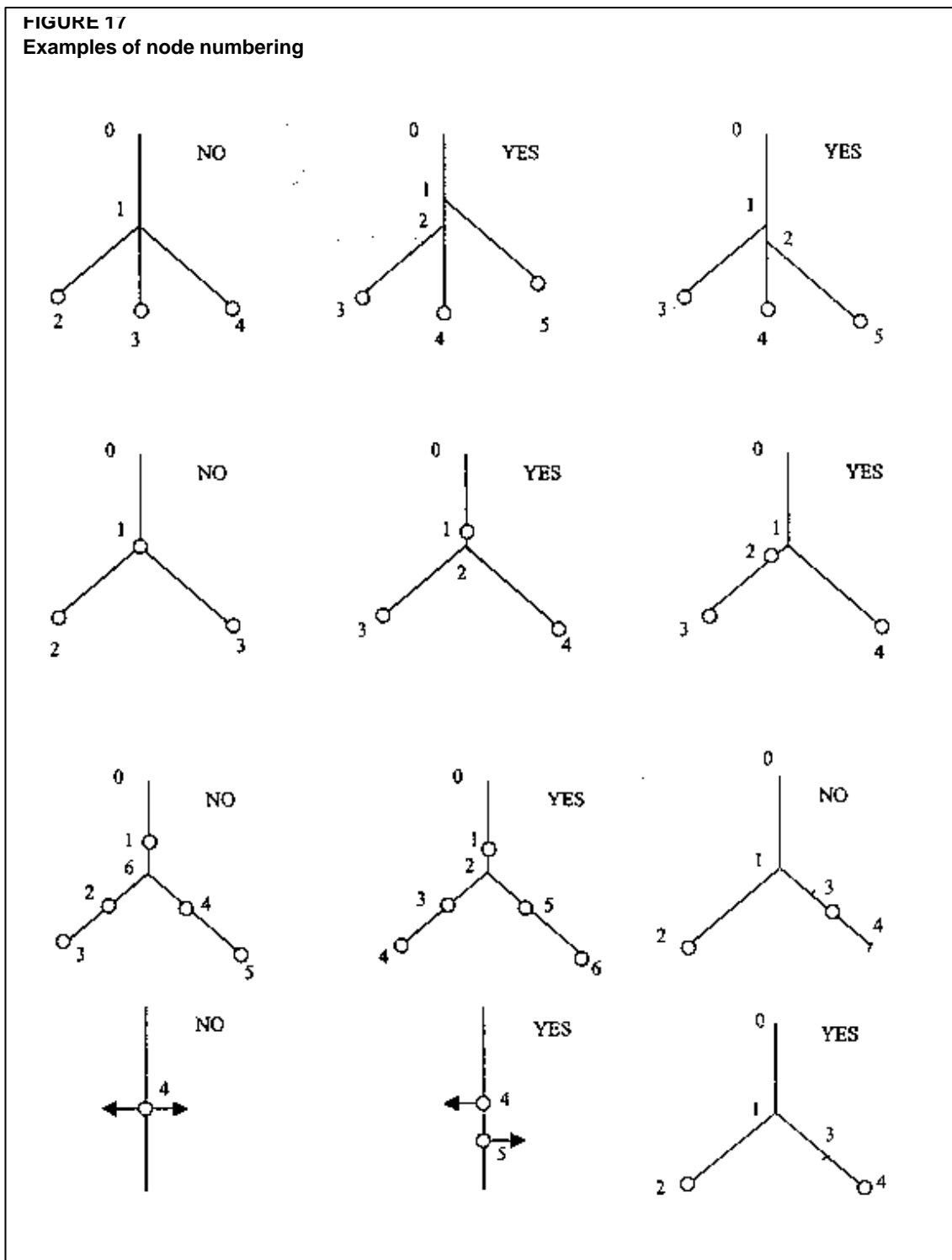

- area irrigated by each hydrant (in hectares); if no hydrant occurs in the node, Area=0 has to be typed,
- hydrant discharge (in $l\ s^{-1}$). It may be selected by clicking in the combo box,
- section length (in m),
- land elevation of the downstream node (in m a.s.l.),

- nominal diameter of the section pipe (in mm). This information is needed when the program is used for the analysis of the network. In the design stage, Diameter=0 must be considered.

In Figure 18, an example of the sub-menu “Edit/network layout” is reported. Additional options are available on the bottom of the screen. They may be activated by clicking on the button: Add Node, Canc Node, Ins Node and Find Section, respectively for adding a new node, delete a node, insert a node and for finding a section. The exit button closes the sub menu.

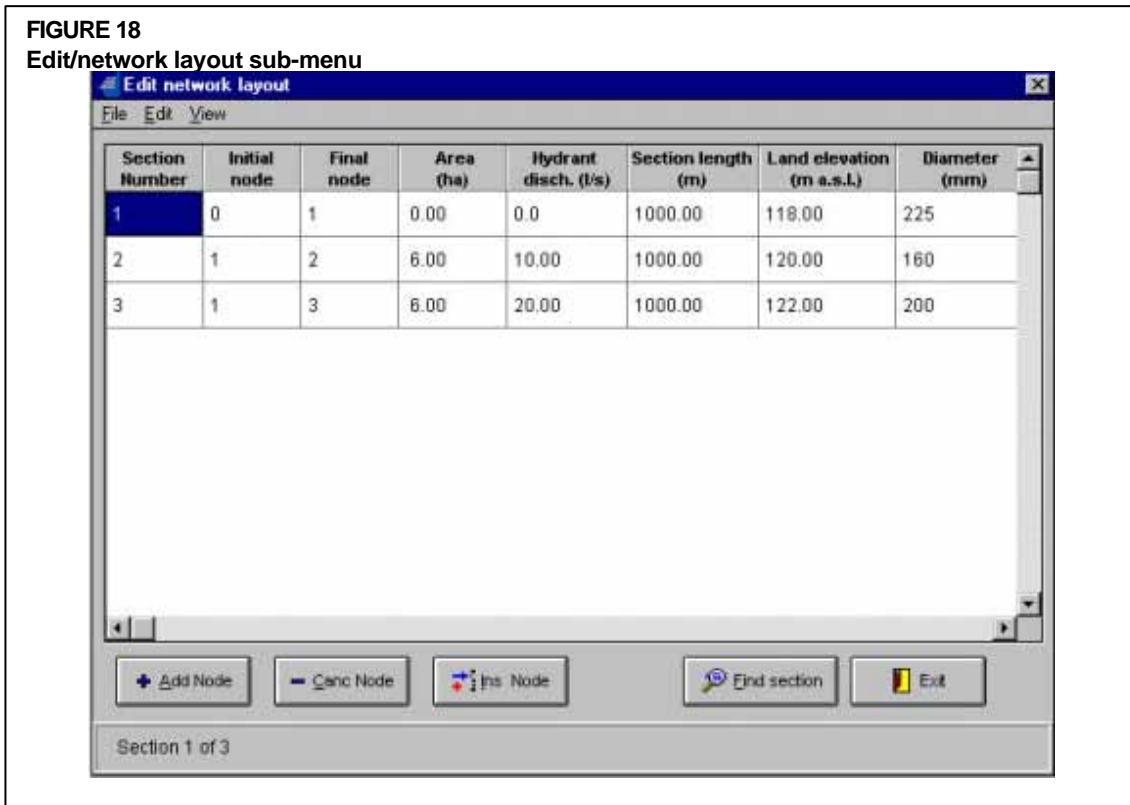

When the network layout is completed, the “Edit/list of pipes” sub menu is selected and Figure 19 will appear.

The list of commercial diameters (in mm) is inserted in the “Edit/list of pipes” sub-menu. The list has to be completed by the thickness (in mm) of the pipes, the roughness (γ , Bazin coefficient) and the unitary cost of the pipe. An internal procedure of the COPAM package will link, automatically, the currency to the regional setting properties of your computer. The pipes unitary costs are typed in increasing order. The nominal diameters are typed in the grid. When the nominal diameter corresponds to the internal diameter, the pipe thickness is considered equal to zero. The types of pipes are identified by the Bazin roughness coefficient.

In the sub-menu “Edit/Description” (Figure 20), the description of the file may be typed. This information is important when a large number of data files are managed to aid with recognition.

FIGURE 19
Edit list of pipes sub-menu

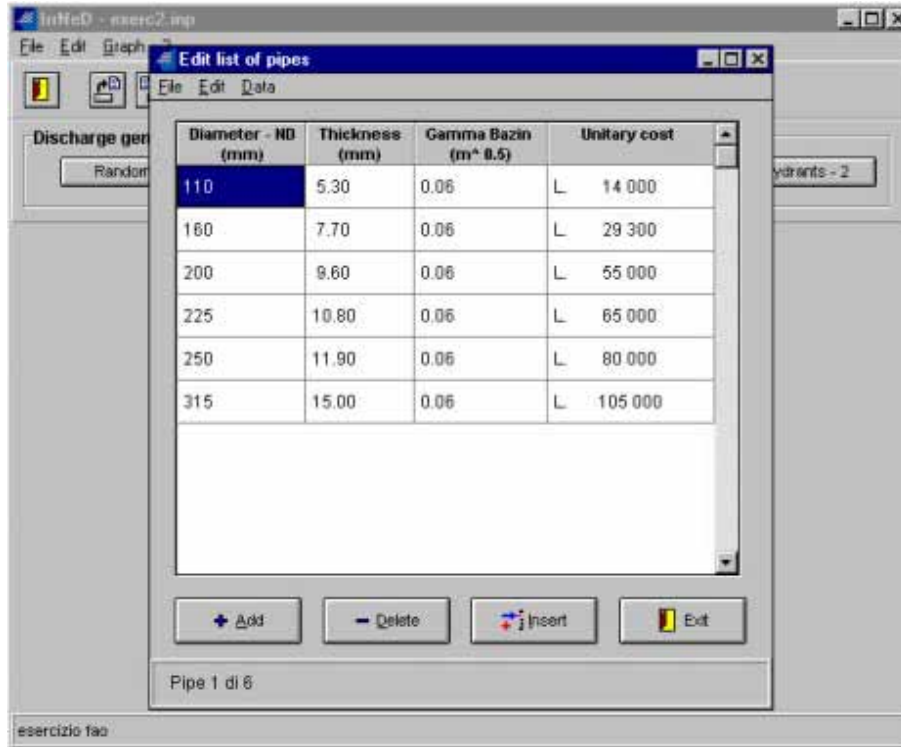

FIGURE 20
Edit description sub-menu

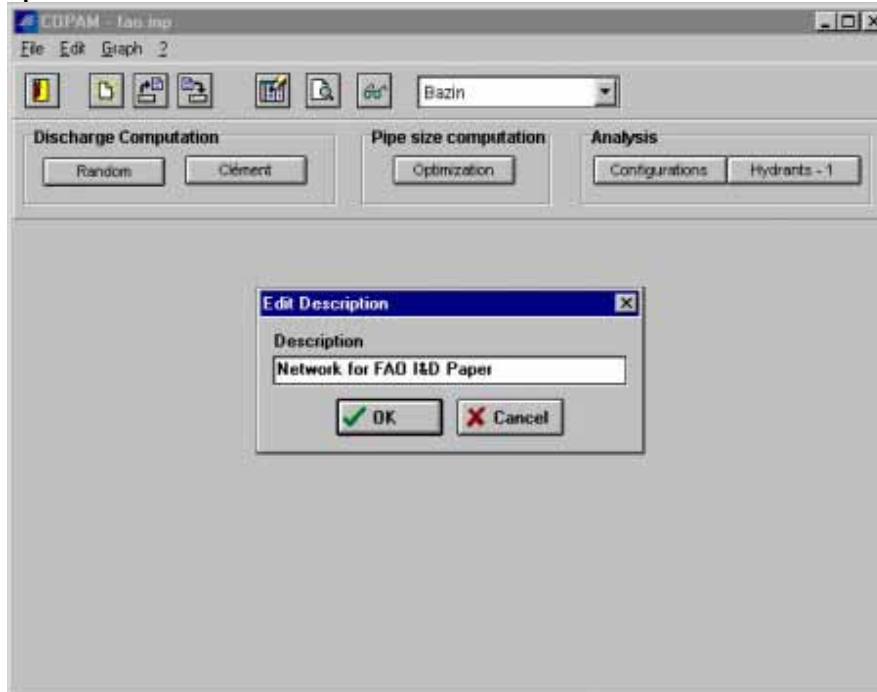

FIGURE 21
Toolbar button "Check input file"

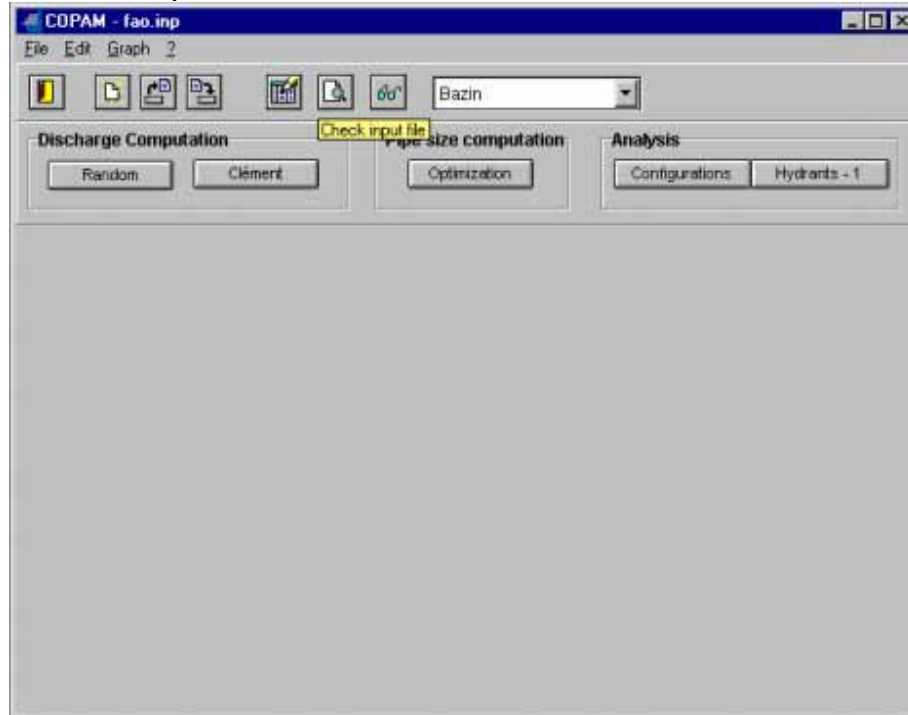
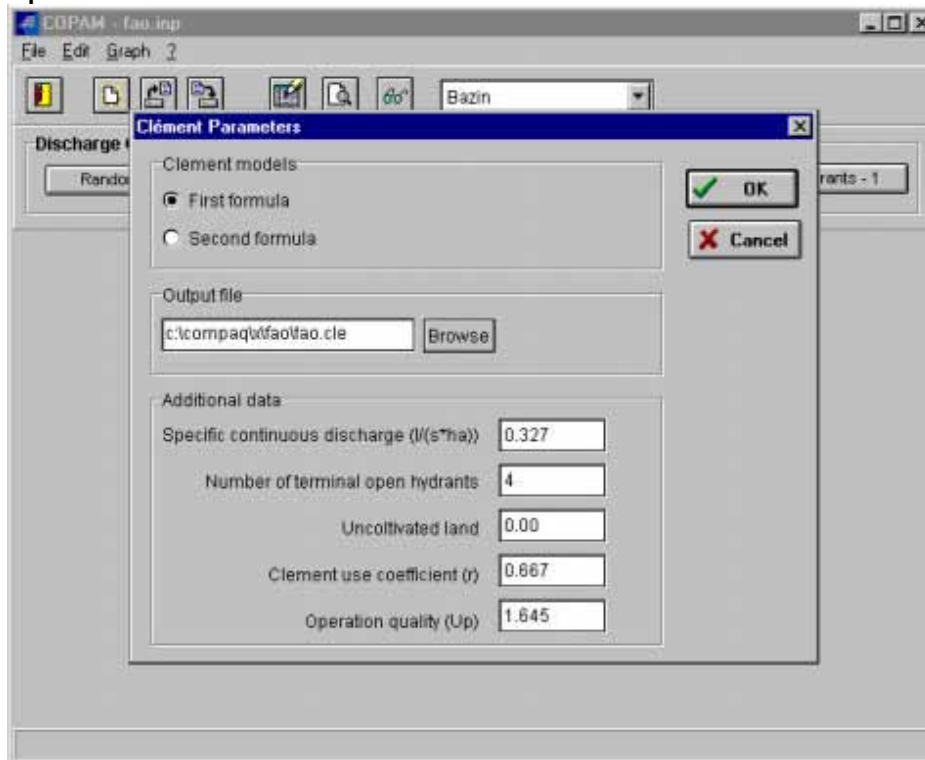

FIGURE 22
Clément parameters: 1st Clément formula



An additional option is available in the COPAM package: the toolbar button “Check input file” (see Figure 21). It checks for the most common errors in the input file.

Computation of discharges

When the set “Discharge computation” is selected, two different programs are available: Clément and Random. The program “Clément” allow the computation of the discharges flowing into the network through the first and the second Clément models. When the first one is selected, additional parameters have to be typed in the “Clément parameters/sub-menu” (Figure 22). They are the:

- specific continuous discharge (in $l\ s^{-1}\ ha^{-1}$)
- minimum number of terminal open hydrants
- percentage of uncultivated land (in %)
- Clément use coefficient (r)
- Clément operation quality, $U(P_q)$.

An example of the output file of the program “Clément” is the one reported in Table 2. The name of the output file is typed in the appropriate edit box and the extension “.cle” is automatically assigned to the file.

The Second Clément's model

Basic theory

Considering the limitations in the first formulation, Clément developed a second model for calculating discharges in irrigation systems operating on-demand (Clément, 1966). This second Clément model is based on the Markovian stochastic theory of birth and death processes. It is summarized hereafter. The complete formulation is reported in Clément (1966) and Lamaddalena (1997). The derivation of the second Clément model is based on some fundamental concepts on the theory of the stationary Markovian processes.

Consider a set of customers arriving at a service station (hydrants in the case of an irrigation system). The pattern of arrivals is described by a distribution function of times of arrival. The customers require different times to be served and, thus, the times of service are described by another statistical distribution function. For an irrigation system we can consider:

- customers in service, which is the average number of arrivals during the average time period of operation of a hydrant;
- customers served, which is the average number of hydrants operating at a given instant t ;
- customers in the queue, which is the average number of arrivals when the system is saturated (during the average waiting time).

Consider a generic system characterized by a random function, $X(t)$, assuming values 1, 2,, N , which represents any possible state of the system.

In the case of an irrigation system, the state of the system is defined by the number of hydrants in operation, while birth and death correspond to opening or closing one hydrant, respectively.

Consider an irrigation network having R hydrants. Let us assume that the operating time for all hydrants follows the same distribution function with average duration of the hydrants operation equal to the average irrigation time, IT . Furthermore, let us assume that the network has been designed with the hypothesis of having N hydrants simultaneously open ($N < R$).

Define P_{SAT} as the probability of saturation of a network equipped with $(R-1)$ hydrants and u' the standard normal variable. It may be demonstrated (Clément, 1966; Lamaddalena, 1997) that:

$$u' = \frac{N - R p}{\sqrt{R p (1 - p)}} \quad (16)$$

and

$$P_{SAT} = \frac{1 - \Psi(u')}{\sqrt{R p (1 - p)} \Pi(u')} \quad (17)$$

where $\Psi(u')$ and $\Pi(u')$ are, respectively, the Gaussian probability distribution function and the Gaussian cumulative distribution function. Making:

$$F(u') = \frac{\Psi(u')}{\Pi(u')} \quad (18)$$

the Equation 17 becomes

$$P_{SAT} = \frac{1}{\sqrt{R p (1 - p)}} F(u') \quad (19)$$

At this stage, it is easy to fix the standard normal variable, u' , according to the target probability, p , and to determine the corresponding values of $\Psi(u')$ and $\Pi(u')$ and also the value of $F(u')$ ¹. In fact, p is given by the Equation 2, P_{SAT} can be selected (usually, $P_{SAT} = 0.01$ is suggested) and $F(u')$ can be calculated using:

$$F(u') = P_{SAT} \sqrt{R p (1 - p)} \quad (20)$$

from a diagram representing $F(u')$ as a function of u' , or directly from the equation representing such a function (Figure 23). It is then possible to determine the corresponding value of u' and, using the Equation 16, we can finally calculate the number of hydrants simultaneously operating in the network:

$$N = R p + u' \sqrt{R p (1 - p)} \quad (21)$$

where Equation 21 represents the second formula of Clément.

¹ It is possible to use the statistical tables giving, for each value of u' , the corresponding values of $\Psi(u')$ and $\Pi(u')$ and the corresponding functions. For the present work the functions $\Psi(u')$ and $\Pi(u')$ have been calculated and introduced in a computer program for solving the discharge calculation by using the 2nd Clément's formula.

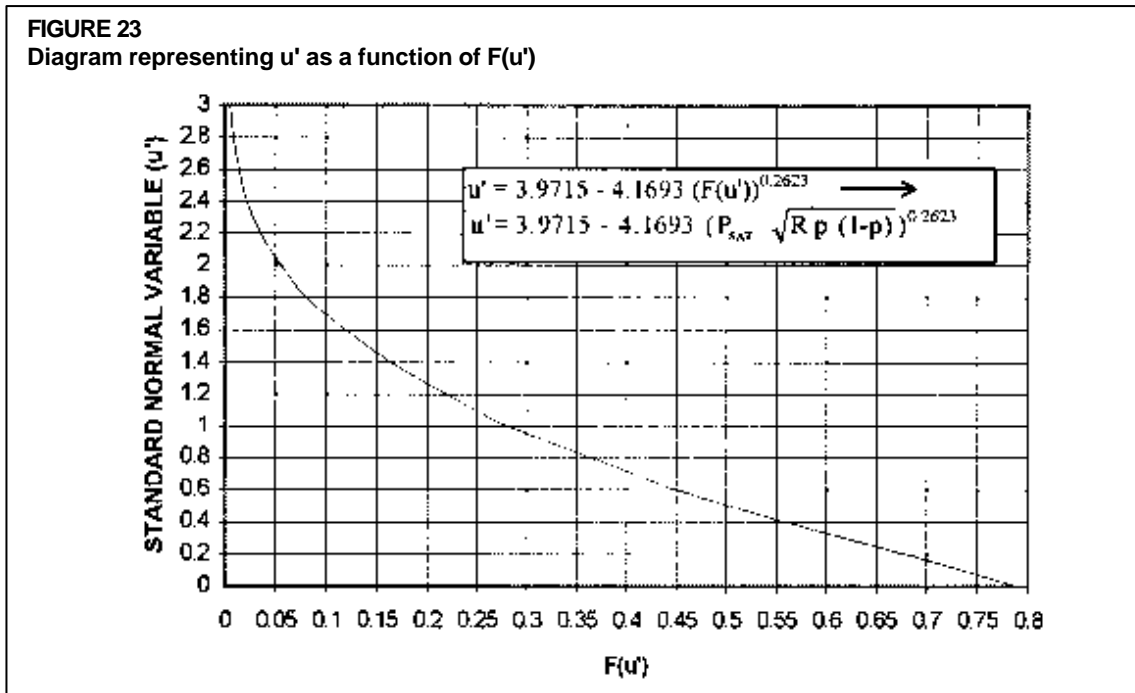

The structure of this second formula of Clément is similar to the first Clément formula but, in this case, u' is not a constant depending on the selected cumulative probability (corresponding to the quality of operation of the network), but it is a function of P_{SAT} , p and R .

The second Clément model is based on the theory of birth and death processes. This hypothesis limits its applicability. In fact, this theory is well applied for designing telephone lines, where if the busy line is engaged (saturation) the customer has to call later. But for irrigation systems it is not so easy to establish saturation conditions. Furthermore, also when the system is saturated farmers may decide to irrigate with a lower pressure and/or discharge at the hydrant. Finally, the complexity in mathematical approach and the negligible differences in results pushed all designers to apply anytime the first model instead of the second one. In Table 3, the discharges flowing into each section of the network in the example are reported.

Applicability of the 2nd Clément model

The computer package COPAM may be used for computing the discharges into each section of an irrigation network by using the 2nd Clément model. The ‘Clément parameters/sub-menu’ of the Clément program (see Figure 24) is filled with the parameters described above.

The application of the 1st and the 2nd Clément models for computing the discharges into an large Italian irrigation network (the one illustrated in the Annex 1) is shown hereafter. The following design data were used for these calculations. The network is equipped with 660 hydrants of 10 l s^{-1} and the design values of the irrigated area A_i , the specific continuous discharge, q_s , and the coefficient of utilization of the network, r , are respectively: $A_i = 2030 \text{ ha}$, $q_s = 0.327 \text{ l s}^{-1} \text{ ha}^{-1}$ and $r = 0.66$. The 1st Clément's model was applied using the cumulative probability $P_q=95\%$ (corresponding to $U(P_q) = 1.645$), while the 2nd Clément's model was applied using the probability of saturation $P_{SAT}=1\%$.

BOX 2: APPLICATION OF THE SECOND CLÉMENT MODEL FOR THE COMPUTATION OF FLOWS IN AN ON-DEMAND NETWORK

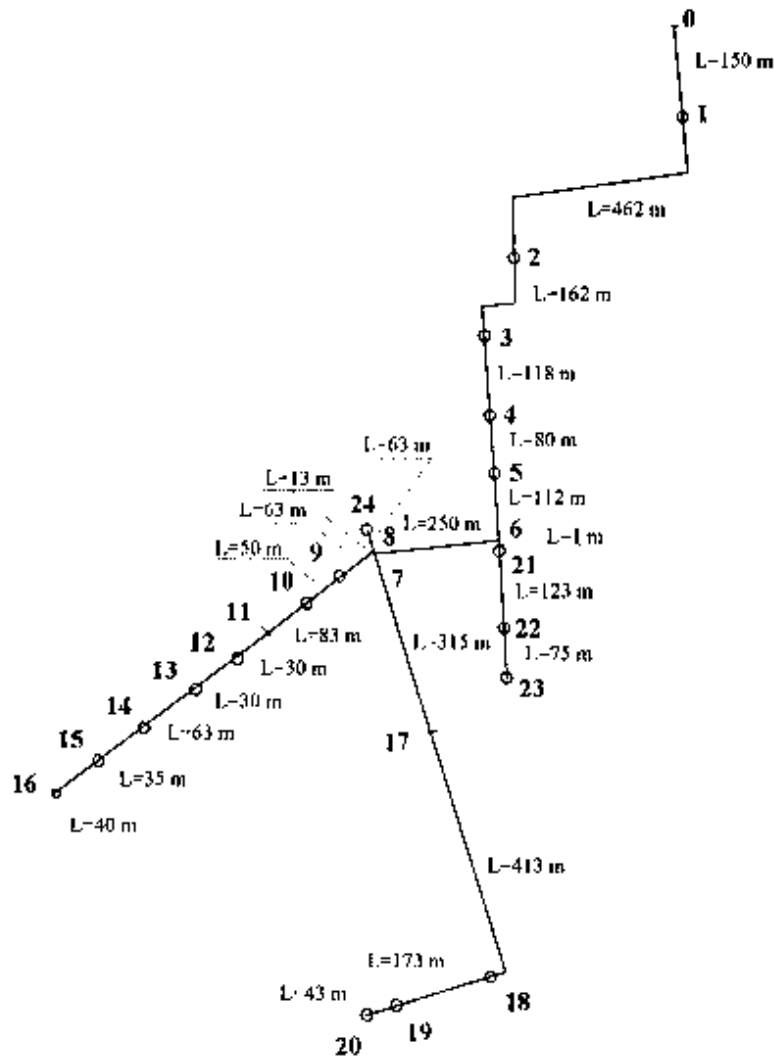

Data:

q_s = specific continuous discharge (24/24 hours) = $0.327 \text{ l s}^{-1} \text{ ha}^{-1}$

A_p = area of the plot to be irrigated = 3 ha

A = total irrigable area = $3 \cdot 19 = 57 \text{ ha}$

d = nominal discharge of the hydrants = 10 l s^{-1}

P_{SAT} = probability of saturation = 0.01

r = use coefficient = 0.667

R = total number of hydrants = 19

N_{ba} = minimum number of hydrants in simultaneous operation = 4

BOX 2 Cont'd

$$p = \text{elementary probability} = \frac{q_s A}{rRd} = \frac{0.327 \cdot 57}{0.667 \cdot 19 \cdot 10} = 0.147$$

$$u' = \text{standard normal variable} = 3.9715 - 4.1693 (P_{\text{SAT}} \sqrt{Rp(1-p)})^{0.2623}$$

1) Number of hydrants simultaneously operating downstream the section 0-1:

$$N_{0-1} = Rp + u' \sqrt{Rp(1-p)} =$$

$$19 \cdot 0.147 + \left\{ 3.9715 - 4.1693 \left[(0.01 \sqrt{19 \cdot 0.147 \cdot (1-0.147)}) \right]^{0.2623} \right\} \sqrt{19 \cdot 0.147 \cdot (1-0.147)}$$

$$= 6.77$$

$$\text{We assume } N_{0-1} = 7^1$$

The design discharge downstream the section 0-1 is:

$$Q_{0-1} = N_{0-1} \cdot d = 7 \cdot 10 = 70 \text{ l s}^{-1}$$

2) Number of hydrants in simultaneous operation downstream the section 1-2:

$$N_{1-2} = Rp + u' \sqrt{Rp(1-p)} =$$

$$18 \cdot 0.147 + \left\{ 3.9715 - 4.1693 \left[(0.01 \sqrt{18 \cdot 0.147 \cdot (1-0.147)}) \right]^{0.2623} \right\} \sqrt{18 \cdot 0.147 \cdot (1-0.147)} =$$

$$= 6.53$$

$$\text{We assume } N_{1-2} = 7$$

The design discharge downstream the section 1-2 is:

$$Q_{1-2} = N_{1-2} \cdot d = 7 \cdot 10 = 70 \text{ l s}^{-1}$$

3) Number of hydrants in simultaneous operation downstream the section 2-3:

$$N_{2-3} = Rp + u' \sqrt{Rp(1-p)} =$$

$$17 \cdot 0.147 + \left\{ 3.9715 - 4.1693 \left[(0.01 \sqrt{17 \cdot 0.147 \cdot (1-0.147)}) \right]^{0.2623} \right\} \sqrt{17 \cdot 0.147 \cdot (1-0.147)} =$$

$$6.29$$

$$\text{We assume } N_{2-3} = 6$$

The design discharge downstream the section 2-3 is:

$$Q_{2-3} = N_{2-3} \cdot d = 6 \cdot 10 = 60 \text{ l s}^{-1},$$

and so on for the calculation of the discharges in the other sections.

1 In this example the mathematical approximation was used for computing the discharges in each section of the network.

TABLE 3
Discharges flowing into each section of the network under study (output of the COPAM package: computation with the second Clément model)

Section Number	Initial Node	Final Node	Number of Hydrants	Area (ha)	2nd Clément discharge (l/s)
1	0	1	19	57.00	70.00
2	1	2	18	54.00	70.00
3	2	3	17	51.00	60.00
4	3	4	16	48.00	60.00
5	4	5	15	45.00	60.00
6	5	6	14	42.00	60.00
7	6	7	11	33.00	50.00
8	7	8	8	24.00	40.00
9	8	9	7	21.00	40.00
10	9	10	6	18.00	40.00
11	10	11	5	15.00	40.00
12	11	12	5	15.00	40.00
13	12	13	4	12.00	40.00
14	13	14	3	9.00	30.00
15	14	15	2	6.00	20.00
16	15	16	1	3.00	10.00
17	7	17	3	9.00	30.00
18	17	18	3	9.00	30.00
19	18	19	2	6.00	20.00
20	19	20	1	3.00	10.00
21	6	21	3	9.00	30.00
22	21	22	2	6.00	20.00
23	22	23	1	3.00	10.00
24	8	24	1	3.00	10.00

FIGURE 24
Clément parameters: 2nd Clément formula

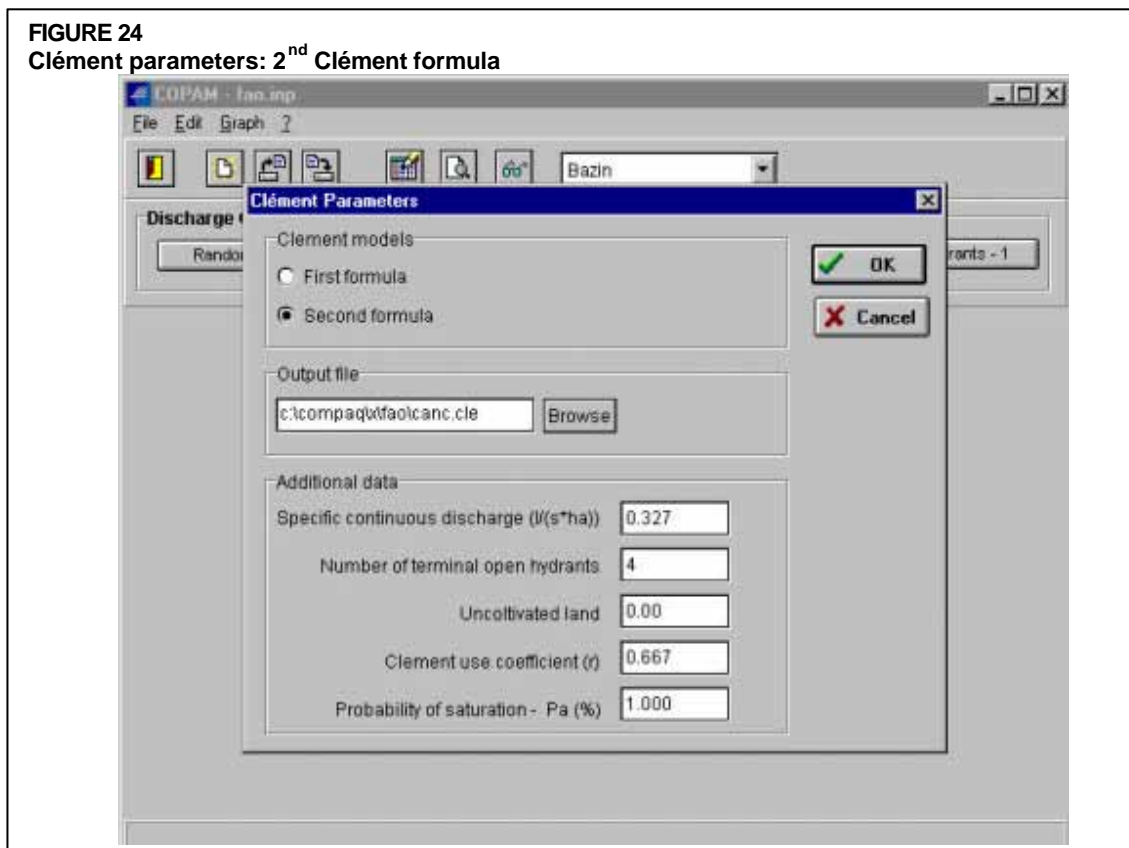

FIGURE 25
Comparison between discharges computed with the 1st and the 2nd Clément equations applied to the Italian irrigation network illustrated in Annex 1

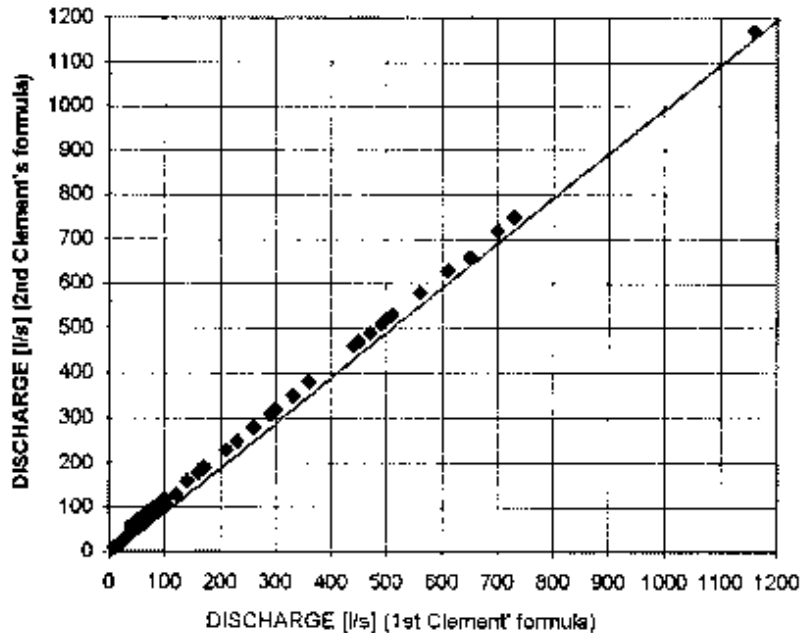
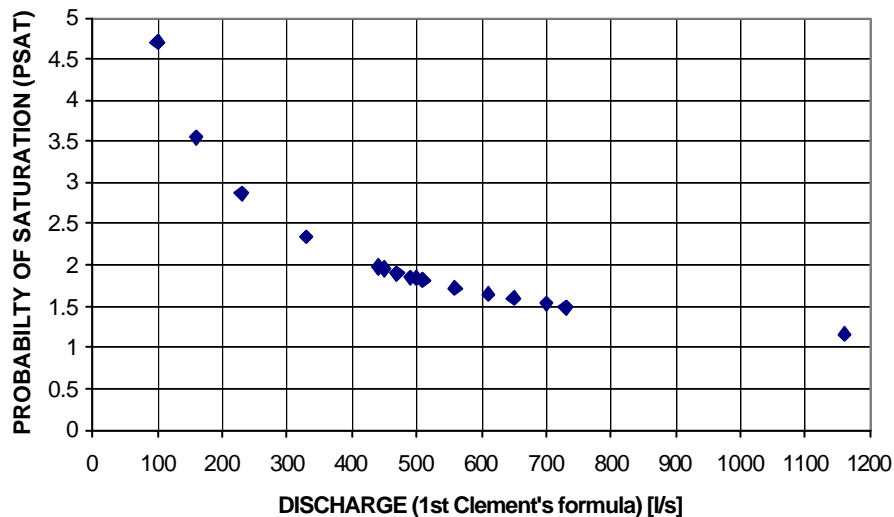
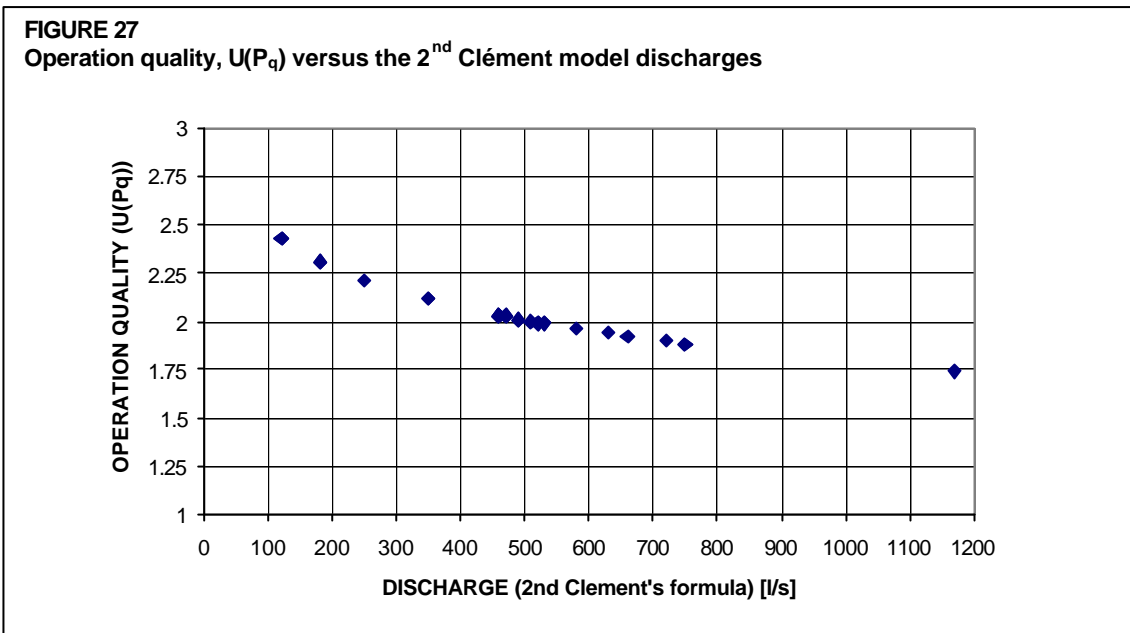

FIGURE 26
Probability of saturation versus the 1st Clément model discharges



The results of the application are summarized in Figure 25 which shows that, for the case under study, using the second model slightly higher discharges are obtained. Further analyses have shown that when the probability of saturation P_{SAT} is computed using the discharges given by the 1st Clément model (using the above design parameters) it becomes evident (Figure 26) that P_{SAT} would be near to 5% for low discharges but would approach $P_{SAT} = 1\%$ for higher discharges. When $U(P_q)$ is computed from the discharges corresponding to the 2^d Clément model, similar results are obtained with a limit value of $U(P_q)$ close to $U(P_q) = 1.645$ (Figure 27).



This example calculation showed that results from both Clément equations are compatible and differences are negligible in practice. Because of the limitation of the theory of birth and death processes applied to the irrigation networks and the mathematical complexity almost all designers use the first model instead of the second.

SEVERAL FLOW REGIMES MODEL (SFR MODEL)

The configuration of discharges (flow regimes) in an irrigation network greatly affects design and operation conditions. In the next sections a model for simulating the water demand in a pressurized irrigation system operating on-demand is described.

Model for generating random discharges

The following approach is proposed in this section for simulating the possible operation conditions of an on-demand irrigation system. It operates using the random generation of K hydrants simultaneously opened among the total number R (with $K < R$). This generation is performed to consider the temporal variability of the discharges flowing into the irrigation network. Each generation, according to the definition reported in the technical literature (CTGREF, 1979; Bethery *et al.*, 1981) produces a hydrants configuration. Each hydrants configuration corresponds to a discharge configuration. Therefore, the discharge in the sections of the network is calculated as the sum of the discharges withdrawn from the downstream opened hydrants.

Before illustrating the procedure used for the generation of discharge configurations, it is important to underline that the use of a computer for generating random numbers is considered conceptually impossible. In fact, any program will produce an output that is predictable, hence not truly random because the numbers are not unrelated. Nevertheless, practical computer random number generators are in common use (Knuth, 1981). To distinguish purely random physical process from computer-generated sequences, the term pseudo-random is used.

There exists a body of random number generators which mutually do satisfy the definition over a very broad class of application programs. But what is random enough for one application may not be random enough for another. The chi-square test may be used to verify the goodness of the random generation for a particular application (Press *et al.*, 1989; Knuth, 1981).

For generating random discharge configurations, uniform deviates are applied. The uniform deviates are just random numbers which lie within a specified range, with any one random number in the range just as likely as any other (Press *et al.*, 1989).

The procedure utilized is as follows (see Figure 28):

- 1- Every node of the system receives an identification number, j .
- 2- Since some nodes do not correspond to hydrants, a code identification of the hydrants is assigned ($ch=0$ when there is no hydrant at the node, $ch=1$ when there is a hydrant with nominal discharge of 5 l s^{-1} , $ch=2$ when there is a hydrant with nominal discharge of 10 l s^{-1} , $ch=3$ when there is a hydrant with nominal discharge of 20 l s^{-1}).
- 3- Definition of a list of discharges to be tested.
- 4- Definition of the number of hydrants configuration to be generated, corresponding to the discharges defined in the previous list.
- 5- Aggregation of the hydrants discharges in each configuration, in order to calculate the discharges flowing into the sections of the network (discharge configuration).

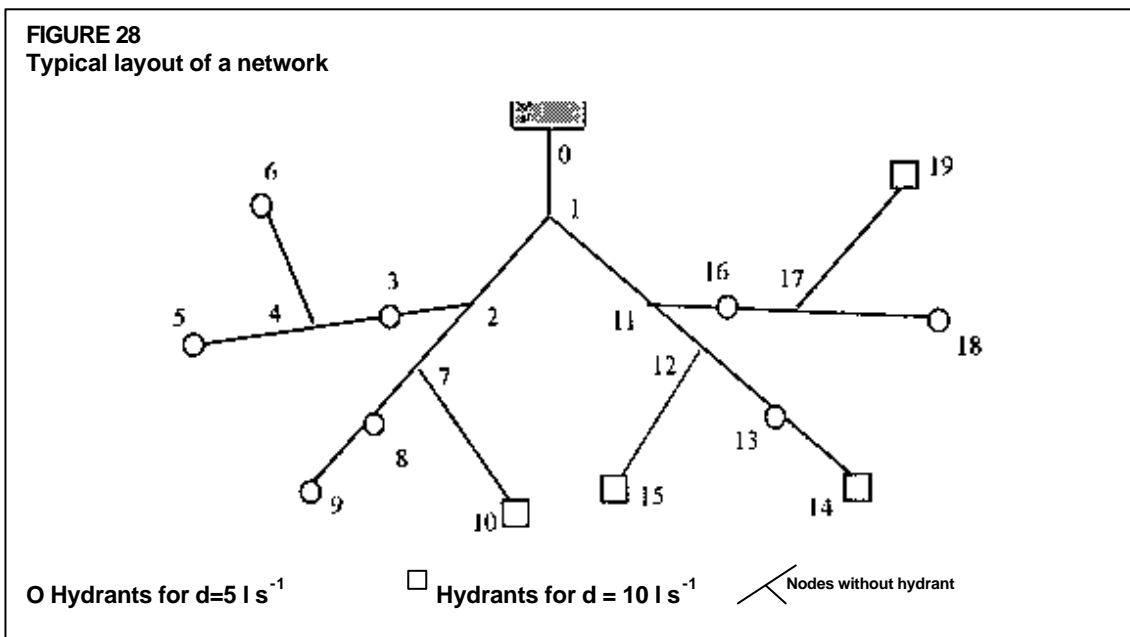

A computer program written in Turbo Pascal, version 6.0 generates random sequences using the internal procedure called Random (Schildt, 1986). The random number generator is initialized by the procedure Randomize. The reliability of the Turbo Pascal random number generator has been verified by Schildt (1986). Additional tests have been also performed by El Yacoubi (1994) and Lamaddalena (1997). The program for the random generation of discharge configurations (RGM: Random Generation Model) is integrated in the COPAM package. It is selected by clicking on the appropriate button (Figure 29). Then Figure 30 will appear on the screen. The input data for the irrigation network were illustrated in the previous section.

FIGURE 29
Random generation program

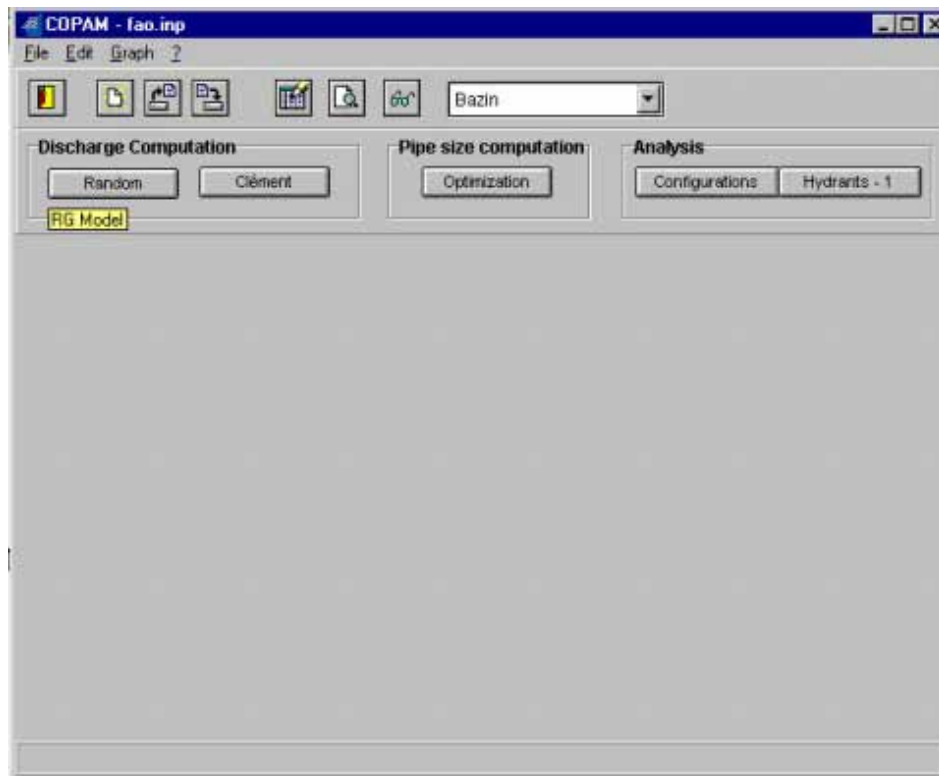

The RG Model may be used for two different purposes:

- analysis of existing irrigation systems;
- design of new irrigation systems.

In the first case, this model is based on the knowledge of the demand hydrograph at the upstream end of the network. In fact, it allows the selection of the upstream discharge corresponding to various hydrant configurations. The value of the upstream discharge is inserted in the appropriate edit box (see Figure 30). Corresponding to the selected discharge, a number of hydrants simultaneously operating (hydrant configuration) is automatically withdrawn. This procedure is repeated for several configurations and is used for analysing the system, as illustrated in the chapter 5. The number of configurations (or flow regimes) to generate is typed in the appropriate edit box (see Figure 30). It must be multiple of 10.

All the generated flow regimes are stored in an output file with its name typed in the appropriate edit box. The extension “.ran” is automatically assigned to this output file.

When a new irrigation system is designed, the upstream discharge is not known a priori. Therefore, to allow the generation of different hydrants configurations, such discharge may be computed, for example, with the Clément models¹. This is achieved through the COPAM

¹ Other models for generating the upstream discharges are under study. Nevertheless, despite the good improvements that have been made in the generation of the upstream withdrawn volumes, the problem of transformation from volumes to discharges has still not been solved because of a number of

FIGURE 30
Random generation parameters

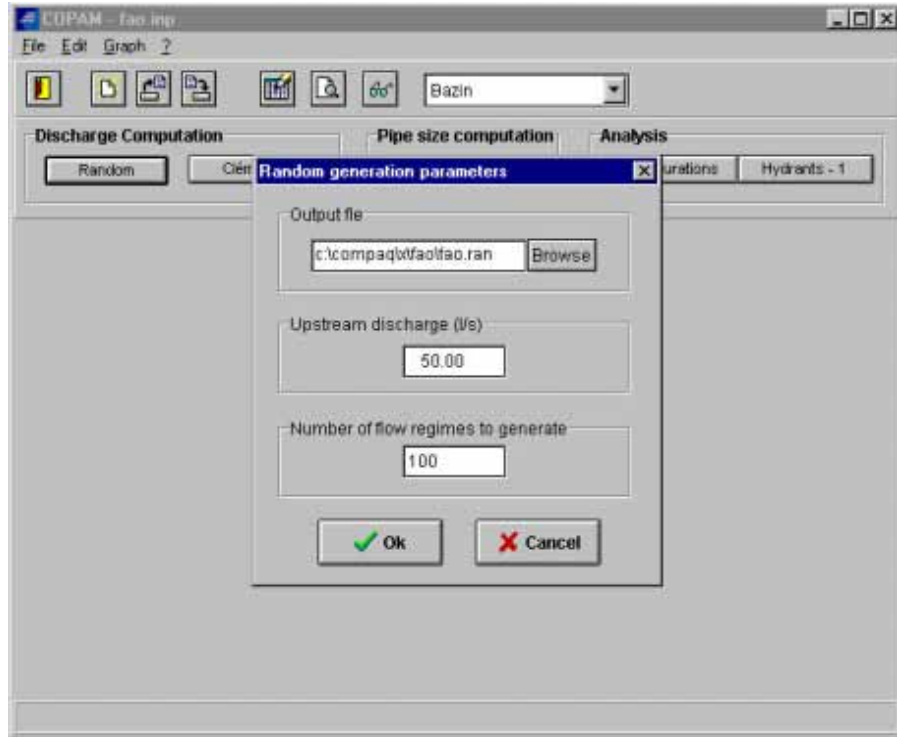

package as explained in the previous section. The discharge value is allocated in the edit box “Upstream discharge” of the “Random generation parameters”. After including the number of configurations to be generated in the appropriate edit box (it must be multiple of 10), operation of the network is simulated by generating the hydrants configurations. These hydrants configurations, stored in a pre-selected output file, are taken into account for computing the optimal pipe size of the network by using the approach illustrated in the chapter 4. Applications of the above methodologies for design and analysis of Italian irrigation networks are reported in Lamaddalena (1997).

uncertainties involved in that process. Some authors (Abdellaoui, 1986; El Yacoubi, 1994; Pereira et al., 1995; Lamaddalena, 1997) presented interesting approaches for the solution of such a problem but only a few applications are available and additional tests are needed for validation and for generalizing the applicability of such models. For this reason, the first Clement model is preferred for the computation of the discharge at the upstream end of the network and, in correspondence of such discharge, a large number of hydrant configurations may be generated. In this way, the actual operation conditions are simulated and are taken into account for the design (and/or the analysis) of the irrigation system.

Chapter 4

Pipe-size calculation

The problem of calculating the optimal pipe size diameters of an irrigation network has attracted the attention of many researchers and designers. Many optimization models based on linear programming (LP), non-linear programming (NLP) and dynamic programming (DP) techniques are available in literature. These models give important improvements to practical problems through less costly solutions and less computation time respect to the classical approaches.

One limitation of the optimization models is that they consider only One Flow Regime (OFR) during the process of the pipe size computation. With this kind of approach, there is no assurance that the system selected is the least costly and compatible with the required performance. Indeed, in on-demand irrigation systems, the distribution of flows in each section may strongly vary in time and space. Thus, several flow regimes (SFR) should be taken into account during the computation process.

In this chapter an optimization model using the Labye's Iterative discontinuous algorithm is presented and applied for the case of One Flow Regime and extended to the case of Several Flow Regimes.

OPTIMIZATION OF PIPE DIAMETERS WITH OFRM

Review on optimization procedures

Research on optimization procedures to design water distribution networks have been reported since the 1960s. Karmeli *et al.* (1968), Schaake and Lai (1969), and Lieng (1971) developed optimization models for solving branched networks where a given demand pattern was used to define the flow uniquely in the pipes. Afterwards, important efforts have been made by Alperovits and Shamir (1977), Quindri *et al.* (1981), Morgan and Goulter (1985) for solving looped systems, where infinite number of distributions of flow can meet a specific demand pattern. Alperovits and Shamir (1977) used fundamental linear programming formulation but their approach is severely limited to small size systems. The approach by Quindri *et al.* (1981) may solve larger systems but only pipes are included in the design and no additional components are considered (e.g. pumping station, reservoirs, valves). In the approach by Morgan and Goulter (1985), the cost of components is not included in the objective function and multiple runs are required to determine the best solution.

Lansley and Mays (1989) proposed a methodology for determining the optimal design of water distribution systems considering the pipe size, the pumping station and reservoirs. In addition, the optimal setting for control and pressure-reducing valves can be determined. This methodology considers the design problem as a non-linear one, where all the typical components of a network are designed while analyzing multiple alternative discharges. This procedure still is computationally intensive and requires a large number of iterations to obtain the solution, especially when applied to large networks.

In view of the concerns sometimes expressed about the use of linear programming when large networks are designed, other approaches have been developed (Labye, 1966 and 1981) using the dynamic programming formulation. Later, another approach was developed (Ait Kadi, 1986) to optimize the network layout and the pipe sizes simultaneously for a network composed by a mainline and secondary parallel branches. This approach (Ait Kadi, 1986) involves two stages. In the first one, an initial solution is constructed by obtaining the optimum layout of the mainline, with each pipe of the network having the smallest allowable diameter. In the second stage, the initial solution is improved by reducing, iteratively, the upstream head and, consequently, varying the layout of the mainline and pipe sizes simultaneously. This iterative process is continued until the optimum head giving the minimum cost of the network is reached.

In recent years, several comprehensive reviews on the state-of-the-art in this field were undertaken (Walsky, 1985b; Goulter, 1987; Walters, 1988). Furthermore, a number of optimization models were assessed (Walsky *et al.*, 1987). An interesting result of the analysis by Walsky *et al.* (1987) was that models produce similar design, both in terms of costs and hardware components selected. The cost associated with the solutions determined by different models only varied by 12%. In addition, the most expensive systems were those with increased level of reliability, imparted by additional storage in the system. Linear programming and dynamic programming for calculating the optimal pipe diameters in irrigation networks have also been compared (Di Santo and Petrillo, 1980a,b; Ait Kadi, 1986).

Di Santo and Petrillo (1980a) demonstrated that a network solved by using both LP and the DP with Bellman's formulation has the same optimal solution. Results obtained by Ait Kadi (1986) for networks solved by using both LP and the Labye's Iterative Discontinuous Method (LIDM) were similar.

The above analyses (Di Santo and Petrillo, 1980a,b; Ait Kadi, 1986; Walsky *et al.*, 1987) indicate that the optimization models utilized were relatively robust and that the optimization is not sensitive to the technique itself. However, it is useful to improve the ability to design and analyze water distribution systems. In fact, system design must consider various critical demand hydrographs to ensure system reliability (Templeman, 1982; Hashimoto *et al.*, 1982). This is valid for both branched and looped networks where the same daily pattern demand may correspond to several configurations of flows in the pipes. In addition, it is useful to examine the extent to which the model techniques and approaches are incorporated into engineering practice.

Better designs have been obtained through optimization models but there has been no guarantee of global optimality, i.e. on what should be the objective of an optimal design. Assuming that an optimal design is the one which meets the applied demands at the least cost (Goulter, 1992), it should incorporate multiple demand conditions, failures in the system components and reliability.

For considering the reliability of the network, a definition of "failure" is necessary. In general, a network failure is an event in which a network is not able to provide sufficient flow or sufficient pressure to meet the demand. Under this definition, failure can occur either if a component (e.g., a pipe) is undersized, or if the actual demand exceeds the design demand. These two cases are independent for practical purposes. A considerable effort has been directed to the reliability question over the last few years.

Relatively little success has been achieved in obtaining comprehensive measures of network reliability that are computationally feasible and physically realistic (Goulter, 1987; Lansey and Basnet, 1990).

The measures that give good representation of reliability are computationally impractical, like the model by Su *et al.* (1987) where 200 min. of computer time is needed for solving a three

loop example. On the other hand, those approaches that are computationally suitable provide very poor description of the network performance. Also, empirical solutions may be considered for improving reliability performance, like the one by Bouchard and Goulter (1991) which proposed to add valves to the links in order to isolate branches during failure for repair.

Despite the efforts in developing optimization models, they are not widely used in practice. The main reasons for this are: they are often too complex to be used and designers are not comfortable with the optimization approaches.

Indeed, Walsky *et al.* (1987) have shown that, by using optimization models, important answers to practical problems are possible which can be verified using simulation techniques. Furthermore, optimization models require less computation time than the classical approaches. Usually, optimization models are difficult to use. The main reason is that they are developed in academic environments where the algorithm is much more important than the input-output interface. In addition, many older engineers have not had opportunity to study formal optimization techniques.

Considering the effort in developing optimization models, it seems reasonable to assert that research should be oriented to integrate simulation and optimization models rather than to develop new optimization algorithms. Techniques for designing optimal pipe diameters for irrigation networks under several discharge configurations need to be improved and tested. Furthermore, reliability of systems need to be well defined in order to be included in the optimization process. Finally, the need for improving the user interface in optimization models software is important (Walsky *et al.*, 1987).

An interesting commercial program for the calculation of the optimal pipe diameters for irrigation networks has been developed by CEMAGREF (1990). This program (XERXES-RENFORS, vers. 5.0) has a user-friendly interface. It computes the discharges with the first Clément formula, or by adding hydrants' discharges, while Labye's discontinuous method is used to compute the optimal diameters. Also, optimal pumping station and optimal reinforcement of the networks may be calculated. This program has interfaces in French and head losses are computed using the Calmon and Lechapt formula.

In the present publication, an effort has been made to develop and distribute the computer program (COPAM). It has an English user-friendly interface and all the calculations are easy. It integrates models for the optimal pipe size computation with models for the analysis of irrigation systems and allow to present the outputs under form of files and graphics. The program facilitates full understanding by the user with the capability to verify the results.

When the design of the pumping stations is required the economic aspects are an important component but the performance analysis of the network is also required. This latter aspect is covered in Chapter 5.

As far as the regulation of the pumping stations is concerned, the reader is referred to Irrigation and Drainage Paper No. 44 (page 128) where the subject is treated in detail. However, the regulation by variable speed pumps is a promising approach concerning energy saving and has been detailed in Chapter 5 (page 74).

Labye's Iterative Discontinuous Method (LIDM) for OFR

The approach proposed by Labye (1981), called Labye's Iterative Discontinuous Method (LIDM), for optimizing pipe sizes in an irrigation network is described in this section. This method is developed in two stages.

In the first stage, an initial solution is constructed giving, for each section k of the network, the minimum commercial diameter (D_{\min}) according to the maximum allowable flow velocity (v_{\max}) in a pipe, when the pipe conveys the calculated discharge (Q_k). The diameter for the section k is calculated by the relationship:

$$(D_{\min})_k = \sqrt{\frac{4Q_k}{\rho v_{\max}}} \quad (22)$$

After knowing the initial diameters, it is possible to calculate the piezometric elevation (Z_0)_{in} at the upstream end of the network, which satisfies the minimum head ($H_{j,\min}$) required at the most unfavorable hydrant (j):

$$(Z_0)_{\text{in}} = H_{j,\min} + ZT_j + \sum_{0 \rightarrow M_j} Y_k \quad (23)$$

where $\sum_{0 \rightarrow M_j} Y_k$ are the head losses along the pathway (M_j) connecting the upstream end of the network to the most unfavourable hydrant.

The initial piezometric elevation (Z_0)_{in} relative to the initial diameters solution is therefore calculated through the relationship (23).

In the second stage, the optimal solution is obtained by iteratively decreasing the upstream piezometric elevation (Z_0)_{in} until reaching the effectively available upstream piezometric elevation, Z_0 , by selecting, for each iteration, the sections for which an increase in diameter produces the minimum increase of the network cost. The selection process at each iteration is carried out as described below.

At any iteration i , the commercial pipe diameters (at most two diameters per section (Labye, 1966)) D_{s+1} and D_s (with $D_{s+1} > D_s$) are known. The coefficient:

$$b_s = \frac{P_{s+1} - P_s}{J_s - J_{s+1}} \quad (24)$$

is defined (Fig. 31), where P_s [ITL] and J_s [m m^{-1}] are, respectively, the cost and the friction loss per unit length of pipe diameter D_s [m], and P_{s+1} [ITL] and J_{s+1} [m m^{-1}] are, respectively, the cost and the friction loss per unit length of pipe diameter D_{s+1} [m].

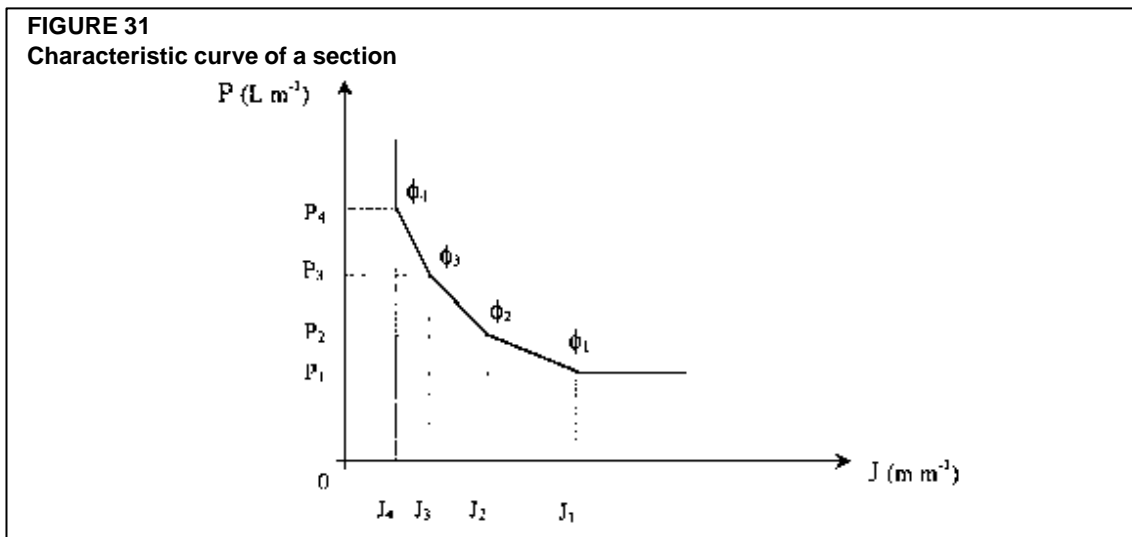

The minimum cost variation, dP , of the elementary scheme $(SN)^*$ (Figure 32) of any sub-network, (SN) , and a section k in series with (SN) , for any given variation, dH' , of the head H' [m], at the upstream end of $(SN)^*$, is obtained by solving the following "local" linear programming (Ait Kadi *et al.*, 1990):

$$\min. dP = - \mathbf{b}_{s,SN} dH - \mathbf{b}_{s,k} dY_k \quad (25)$$

subject to:

$$dH + dY_k = dH' \quad (26)$$

where dH [m] and dY_k [m] are, respectively, the variation of the head at the upstream end of (SN) and the variation of the friction loss in section k .

The optimal solution of the equations (25) and (26) is:

$$dH = dH' \quad \text{and} \quad dY_k = 0 \quad \text{if} \quad \mathbf{b}_{s,SN} < \mathbf{b}_{s,k} \quad (27)$$

$$dH = 0 \quad \text{and} \quad dY_k = dH' \quad \text{if} \quad \mathbf{b}_{s,SN} > \mathbf{b}_{s,k} \quad (28) \dots$$

Therefore, the minimum cost variation, dP , of $(SN)^*$ can be written as:

$$dP = - \mathbf{b}^* dH' \quad \text{with} \quad (29)$$

$$\mathbf{b}^* = \min (\mathbf{b}_{s,SN}, \mathbf{b}_{s,k}) \quad (30)$$

Hence, proceeding from any terminal section of the pipe network, the equation (30) can be used to determine the section that will vary at each iteration. Note that in this process, $\mathbf{b}_{s,SN}$ of the assembly of two sections in derivation is equal to (Fig. 32):

$$\mathbf{b}_{s,SN} = \mathbf{b}_{s,1} + \mathbf{b}_{s,2} \quad (31)$$

whereas, for two sections in series it would be equal to:

$$\mathbf{b}_{s,SN} = \min (\mathbf{b}_{s,1}, \mathbf{b}_{s,2}) \quad (32)$$

In the case of a terminal section with a head in excess at its downstream end ($H_j > H_{j,min}$), the value of $\mathbf{b}_{s,SN}$ to be used in the process is equal to zero as long as the excess head prevails.

The magnitude of dH_i , for each iteration i , is determined as:

$$dH_i = \min (EH_i, \Delta Y_i, \Delta Z_i) \quad (33)$$

where:

EH_i is the minimum value of the excess head prevailing in all the nodes where the head will change;

ΔY_i is the minimum value of $(Y_{ki} - Y^*)$ for those sections which will change in diameters, with Y_{ki} being the value of the head loss in the section k at iteration i , and Y^* is, for this section, the value of the head loss corresponding to the largest diameter over its entire length if the section has two diameters, or the next greater diameter if the section has only one diameter. Note that for those terminal sections with head in excess ($H_j > H_{j,min}$), ΔY_i is equal to the value of this excess ($H_j - H_{j,min}$).

ΔZ_i is the difference between the upstream piezometric elevation, $(Z_0)_i$, at iteration i , and the piezometric elevation, Z_0 , effectively available at the upstream end of the network.

The iterative process is continued until Z_0 is reached, obtaining the optimal solution. An example is described in Box 3.

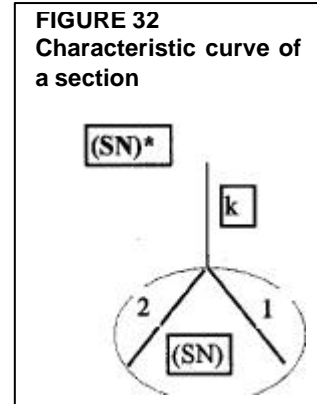

FIGURE 32
Characteristic curve of a section

BOX 3

Using the LIDM, compute the optimal pipe sizes for the network in figure. The following range of flow velocity is considered: $v_{\max} = 2.5 \text{ ms}^{-1}$, $v_{\min} = 0.2 \text{ ms}^{-1}$. The available upstream piezometric elevation is: $Z_0 = 165 \text{ m a.s.l.}$

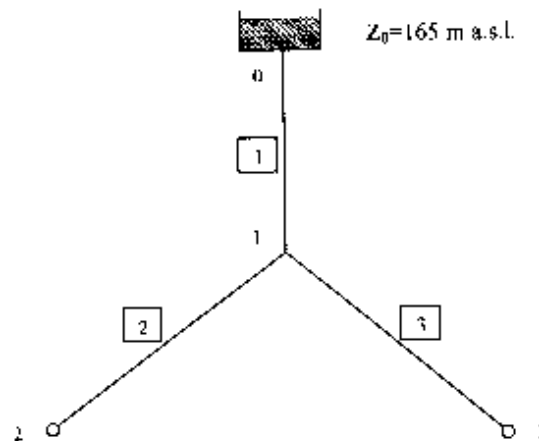

TABLE 3.1
Characteristic of the network

Section Number	Initial Node	Final Node	Discharge (l s^{-1})	Length (m)	Land Elevation (m a.s.l.)	H_{\min} (m)
1	0	1	35	1000	110	20
2	1	2	15	1000	120	30
3	1	3	20	1000	122	30

TABLE 3.2
List of commercial pipes

\varnothing (mm)	Thickness (mm)	γ_{Bazin} ($\text{m}^{0.5}$)	Cost (ITL m^{-1})
110	5.3	0.06	14 000
160	7.7	0.06	29 300
200	9.6	0.06	55 000
225	10.8	0.06	65 000
250	11.9	0.06	80 000
315	15.0	0.06	105 000

Darcy's equation was used for calculating the friction slope J [m m^{-1}] in the pipes:

$$J = u Q^2$$

where

$$u = 0.000857 (1 + 2\gamma D^{-0.5})^2 D^{-5}$$

γ is the roughness parameter of Bazin, expressed in $\text{m}^{0.5}$. Q ($\text{m}^3 \text{ s}^{-1}$) is the discharge flowing into the section and D (m) is the diameter of the section.

BOX 3 Cont'd

By applying the Darcy's equation, the following values of u are obtained:

\bar{E} (mm)	u
110	168.343079
100	23.462156
200	7.293085
225	3.945896
250	2.269560
315	0.683712

The following flow velocities are obtained for each section:

Section 1	
$Q = 35 \text{ l s}^{-1}$	
\bar{E} (mm)	v (ms ⁻¹)
110	4.51
160	2.13
200	1.36
225	1.08
250	0.85
315	0.55

Section 2	
$Q = 15 \text{ l s}^{-1}$	
\bar{E} (mm)	v (ms ⁻¹)
110	1.93
160	0.91
200	0.58
225	0.46
250	0.37
315	0.24

Section 3	
$Q = 20 \text{ l s}^{-1}$	
\bar{E} (mm)	v (ms ⁻¹)
110	2.58
160	1.22
200	0.78
225	0.62
250	0.50
315	0.31

The list of the commercial pipe diameters available for each section, according the allowable range of flow velocities is:

Section Number	\bar{E} (mm)	\bar{E} (mm)	\bar{E} (mm)	\bar{E} (mm)	\bar{E} (mm)	\bar{E} (mm)
1	-	160	200	225	250	315
2	110	160	200	225	250	315
3	-	160	200	225	250	315

Section Number	Discharge (l s ⁻¹)	\bar{E}_{\max} (mm)	\bar{E}_{\min} (mm)
1	35	315	160
2	15	315	110
3	20	315	160

The friction losses are:

Section 1	
\bar{E} (mm)	Jx1000
160	28.74
200	8.93
225	4.83
250	2.78
315	0.84

Section 2	
\bar{E} (mm)	Jx1000
110	37.88
160	5.28
200	1.64
225	0.84
250	0.51
315	0.15

Section 3	
\bar{E} (mm)	Jx1000
160	9.39
200	2.92
225	1.58
250	0.91
315	0.27

BOX 3 Cont'd

The values of the coefficient β are:

$$b_s = \frac{P_{s+1} - P_s}{J_s - J_{s+1}}$$

Section 1	
F (mm)	b/1000
160	1297
200	2439
225	7304
250	1287
315	

Section 2	
F (mm)	b/1000
110	469
160	7064
200	13278
225	39769
250	70064
315	

Section 3	
F (mm)	b/1000
160	3974
200	7469
225	22370
250	39411
315	

- Initial solution

For each section k of the network, the initial solution is constructed giving the minimum commercial diameter (D_{\min}) according to the maximum allowable flow velocity (v_{\max}) in the pipe.

After knowing the initial diameters, it is possible to calculate the piezometric elevation (Z_0)_{in} at the upstream end of the network, which satisfies the minimum head ($H_{j,\min}$) required at the most unfavourable hydrant (j):

$$Z_{0-2} = 150 + J_{110,2} * L_2 + J_{160,1} * L_1 = 150 + 37.88 + 28.74 = 216.63 \text{ m a.s.l.}$$

$$Z_{0-3} = 152 + J_{160,3} * L_3 + J_{160,1} * L_1 = 152 + 9.39 + 28.74 = 190.13 \text{ m a.s.l.}$$

The most unfavourable hydrant in this example is number 2 and, therefore, the initial solution is represented by the upstream piezometric elevation $Z_{0,\text{in}} = 216.62 \text{ m a.s.l.}$ and the initial minimum diameters:

Section Number	D_{\min} (mm)
1	160
2	110
3	160

By starting from the node 0 along the path $0 \rightarrow 3$, it is possible to compute the pressure head on the node 2 and 3. On the node 2 there is no excess head, while on the node 3 there is excess equal to:

$$\Delta H_3 = 216.62 - 28.74 - 9.39 - 152 = 26.49 \text{ m}$$

This implies that $\beta_3=0$. According to the theory of LIDM, we have to compare $\beta_1=1297$ and $\beta_2=469$ in series. The minimum value correspond to β_2 , so we have to change the diameter of the section 2 from $\phi = 110 \text{ mm}$ to $\phi = 160 \text{ mm}$.

At this stage, we have to decrease $Z_{0,\text{in}}$, so we select the minimum value among:

- Excess head on node where the head change: excess on node 3 = 26.49 m

BOX 3 Cont'd

$$- Z_{0,in} - Z_0 = 216.62 - 165 = 51.62 \text{ m}$$

$\Delta Y \longrightarrow$ by changing the diameter of the section 2 from $\phi = 110 \text{ mm}$ to $\phi = 160 \text{ mm}$:

$$\Delta Y = 37.88 - 5.28 = 32.60 \text{ m}$$

The minimum value is 26.49 m

- The solution at the first iteration is:

$$Z_{0,1} = 216.62 - 26.49 = 190.13 \text{ m a.s.l.}$$

This gives the diameters shown below:

Section Number	ϕ_{min} (mm)
1	160
2	160 *
3	160

* By changing the whole diameter on the section 2 we would recover 32.60 m and, in fact, we decrease the upstream piezometric elevation only 26.49 m. This implies that we have a mixage on section 2 between the diameters $\phi = 110 \text{ mm}$ and $\phi = 160 \text{ mm}$. The lengths of such mixage are:

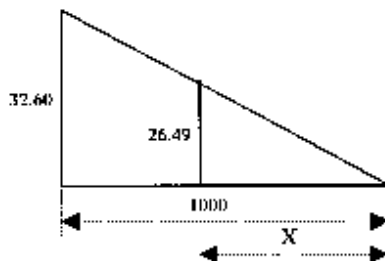

Note that $1000 / 32.60 = X / 26.49$ and

$$X = \frac{1000 \cdot 26.49}{32.60} = 813 \text{ m}$$

This means that 813 m of the section 2 needs a diameter $\phi = 160 \text{ mm}$ and $(1000-813) = 187 \text{ m}$ needs a diameter $\phi = 110 \text{ mm}$.

At this stage, there is no excess head on the nodes 2 and 3. Therefore, the sections 2 and 3 are in parallel, and the values of the coefficients β for identifying the sections to be changed are

$$\text{- for the sections 2 and 3: } \beta = \beta_2 + \beta_3 = 469 + 3974 = 4453$$

$$\text{- for the sections 1: } \beta_1 = 1297$$

The minimum value is β_1 , therefore we have to increase the diameter on the section 1 from $\phi = 160 \text{ mm}$ to $\phi = 200 \text{ mm}$.

BOX 3 Cont'd

We select a the minimum value for $Z_{0,1}$ among:

- Excess head on the nodes where the head change: no head variations on the nodes 2 and 3 occur;

$$- Z_{0,1} - Z_0 = 190.13 - 165 = 25.13 \text{ m}$$

$\Delta Y \longrightarrow$ by changing the diameter of the section 1 from $\phi = 160 \text{ mm}$ to $\phi = 200 \text{ mm}$:

$$\Delta Y = 28.74 - 8.93 = 19.81 \text{ m}$$

The minimum value is 19.81 m, therefore we have to change diameter on the whole section 1 from $\phi = 160 \text{ mm}$ to $\phi = 200 \text{ mm}$.

Therefore, the solution at the second iteration is:

$$Z_{0,2} = 190.13 - 19.81 = 170.32 \text{ m a.s.l.}$$

This gives the diameters shown below:

Section Number	\bar{E}_{\min} (mm)
1	200
2	160-110
3	160

At this stage, there is no excess head on the nodes 2 and 3. Therefore, the sections 2 and 3 are considered in parallel, and the values of the coefficients β for identifying the sections to be changed are

$$- \text{for the sections 2 and 3: } \beta = \beta_2 + \beta_3 = 469 + 3974 = 4453$$

$$- \text{for the sections 1: } \beta_1 = 2439$$

The minimum value is β_1 , so we increase the diameter on the section 1 from $\phi = 200 \text{ mm}$ to $\phi = 225 \text{ mm}$.

We select a minimum value $Z_{0,1}$ among:

- Excess head on the nodes where the head change: no head variations on the nodes 2 and 3 occur;

$$- Z_{0,1} - Z_0 = 170.32 - 165 = 5.32 \text{ m}$$

$\Delta Y \longrightarrow$ by changing the diameter of the section 1 from $\phi = 200 \text{ mm}$ to $\phi = 225 \text{ mm}$:

$$\Delta Y = 8.93 - 4.83 = 4.10 \text{ m}$$

The minimum value is 4.10 m, so we change the diameter on the whole section 1 from $\phi = 200 \text{ mm}$ to $\phi = 225 \text{ mm}$.

Therefore, the solution at the second iteration is:

$$Z_{0,2} = 170.32 - 4.10 = 166.22 \text{ m a.s.l.}$$

This gives the diameters shown below:

Section Number	\bar{E}_{\min} (mm)
1	225
2	160-110
3	160

BOX 3 Cont'd

At this stage, there is still no any excess head on the nodes 2 and 3, so sections 2 and 3 are considered in parallel, and the values of the coefficients β for identifying the sections to be changed are

- for the sections 2 and 3: $\beta = \beta_2 + \beta_3 = 469 + 3974 = 4453$

- for the sections 1: $\beta_1 = 7304$

The minimum value is $\beta = \beta_2 + \beta_3$, so we increase the diameter on the sections 2 and 3.

We select the minimum $Z_{0,2}$ value among:

- Excess head on the nodes where the head change: no head variation on the nodes 2 and 3 occur;

- $Z_{0,2} - Z_0 = 66.22 - 165 = 1.22$ m

ΔY \longrightarrow by changing the diameter of the section 3 from $\phi = 160$ mm to $\phi = 200$ mm:

$$\Delta Y_3 = 9.38 - 2.92 = 6.46$$
 m

ΔY \longrightarrow by changing the whole diameter of the section 2 from $\phi = 110$ mm to $\phi = 160$ mm:

$$\Delta Y_2 = 32.60 - 26.49 = 6.11$$
 m

The minimum value is 1.22 m, so we change part of the diameter $\phi = 110$ mm in the section 2 to $\phi = 160$ mm and we change part of the diameter $\phi = 160$ mm in the section 3 into $\phi = 200$ mm. We will have mixage on the sections 2 and 3.

The solution at the third iteration is:

$$Z_{0,3} = 166.22 - 1.22 = 165 \text{ m a.s.l.}$$

This gives the diameters shown below:

Section Number	\bar{E}_{\min} (mm)
1	225
2	160-110
3	200-160

Mixage on the section 3:

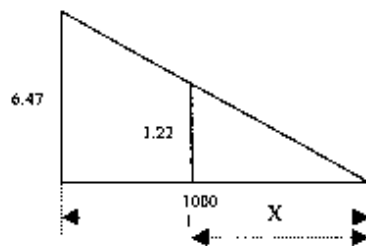

Note that $1000 / 6.47 = X / 1.22$, so

$$X = \frac{1000 \cdot 1.22}{6.47} = 189 \text{ m}$$

This means that 189 m of the section 3 needs a diameter $\phi = 200$ mm and $(1000 - 189) = 811$ m needs a diameter $\phi = 160$ mm.

BOX 3 Cont'd

Mixage on the section 2:

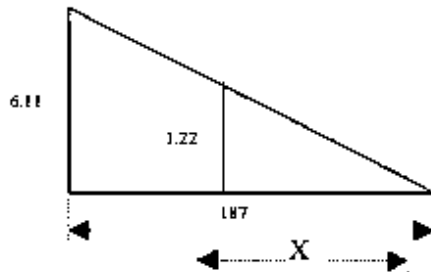

Note that $187 / 6.11 = X / 1.22$, so

$$X = \frac{187 \cdot 1.22}{6.11} = 37 \text{ m}$$

This means that additional 37 m of the section 2 needs a diameter $\phi = 160$ mm, so that $(813+37)=850$ m needs a diameter $\phi = 160$ mm, and $(1000-850)=150$ m needs a diameter $\phi = 110$ mm.

The final solution is:

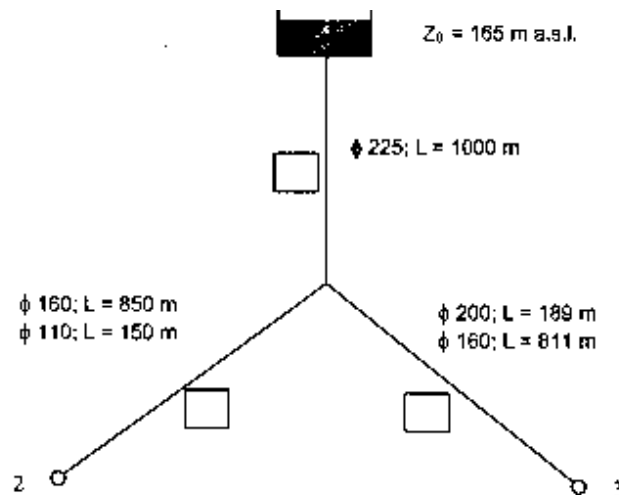

The cost of the network is: 126 162 300 ITL

OPTIMIZATION OF PIPE DIAMETERS WITH SFRM

The above described optimization method considers fixed discharges flowing into the pipes of the network. This is not true for irrigation systems, especially when on-demand delivery schedules are adopted. In these systems, the discharges are strongly variable in time because of the extreme variability of the configurations of hydrants operating simultaneously, which depend on cropping patterns, irrigated areas, meteorological conditions, and farmer's behaviour. For this reason the LIDM has been extended (Ait Kadi *et al.*, 1990; Lamaddalena, 1997) to take

into account the hydraulic happenings in the network which consists of Several Flow Regimes (SFRM). Using a computer program, flow regimes were generated using the RGM approach presented in chapter 3.

Labye's Iterative Discontinuous Method extended for SFR (ELIDM)

The algorithm of the Labye's iterative discontinuous method extended for SFR (Labye, 1981; Ait Kadi *et al.*, 1990) is divided in two stages. In the first stage, an initial solution is constructed giving, for each section k of the network, the minimum commercial diameter $(D_{\min})_k$ according to the maximum allowable flow velocity (v_{\max}) when the pipe conveys the maximum discharge ($Q_{\max,k}$) for all the configurations. The diameter for the section k is calculated by the relationship:

$$(D_{\min})_k = \sqrt{\frac{4 Q_{\max,k}}{\pi v_{\max}}} \quad (34)$$

After knowing the initial diameters, it is possible to calculate, for each configuration r , the piezometric elevation $(Z_0)_{in,r}$ [m a.s.l.] at the upstream end of the network, satisfying the minimum head, $H_{j,\min}$ [m], required at the most unfavorable hydrant, j :

$$(Z_0)_{in,r} = H_{j,\min} + ZT_j + \sum_{0 \rightarrow M_j} Y_{k,r} \quad (35)$$

where $\sum_{0 \rightarrow M_j} Y_{k,r}$ are the head losses along the pathway (M_j) connecting the upstream end of the network to the most unfavorable hydrant when the flow regime occurs.

Within all the configurations of discharges, only those requiring an upstream piezometric elevation, $(Z_0)_{in,r}$, greater than the effectively available one, Z_0 , are considered.

With the first of C possible configurations (r_1), the initial piezometric elevation $(Z_0)_{in,r_1}$, relative to the initial diameters solution, $(D_{\min})_k$, is calculated through the relationship (35). The optimal solution for r_1 is obtained by iteratively decreasing the upstream piezometric elevation. For each iteration, select sections for which a change in diameter produces the minimum increase in the network cost. The selection process for each iteration is described below.

At any iteration (I), the commercial pipe diameters are known. There are no more than two diameters per section (Labye, 1966) with $D_{s+1} > D_s$. The coefficient:

$$b_s = \frac{P_{s+1} - P_s}{J_s - J_{s+1}} \quad (24)$$

is defined, where P_s [ITL] and J_s [$m \ m^{-1}$] are, respectively, the cost and the friction loss per unit length of pipe diameter D_s [m], and P_{s+1} [ITL] and J_{s+1} [$m \ m^{-1}$] are, respectively, the cost and the friction loss per unit length of pipe diameter D_{s+1} [m].

The minimum cost variation, dP , of the elementary scheme $(SN)^*$ (Figure 33) of any sub-network, (SN) , and a section k in series with (SN) , for any given variation, dH' , of the head H' [m], at the upstream end of $(SN)^*$, is obtained by solving the following "local" linear programming (Ait Kadi *et al.*, 1990):

$$\min. dP = - b_{s,SN} dH - b_{s,k} dY_k \quad (36)$$

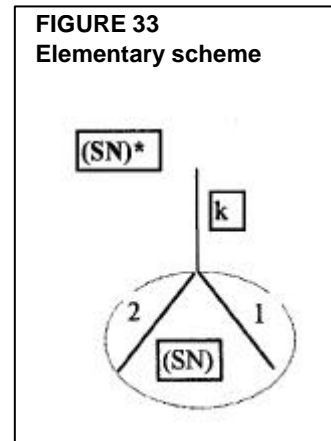

subject to:

$$dH + dY_k = dH' \quad (37)$$

where dH [m] and dY_k [m] are, respectively, the variation of the head at the upstream end of (SN) and the variation of the friction loss in section k . The optimal solution of the equations (36) and (37) is:

$$dH = dH' \quad \text{and} \quad dY_k = 0 \quad \text{if} \quad \mathbf{b}_{s,SN} < \mathbf{b}_{s,k} \quad (38)$$

$$dH = 0 \quad \text{and} \quad dY_k = dH' \quad \text{if} \quad \mathbf{b}_{s,SN} > \mathbf{b}_{s,k} \quad (39)$$

Therefore, the minimum cost variation, dP , of (SN)^{*} can be written as:

$$dP = - \mathbf{b}^* dH' \quad \text{with} \quad (40)$$

$$\mathbf{b}^* = \min (\mathbf{b}_{s,SN}, \mathbf{b}_{s,k}) \quad (41)$$

Hence, proceeding from any terminal section of the pipe network, the equation (40) can be used to determine the section that will vary at each iteration. Note that in this process (Figure 33), $\mathbf{b}_{s,SN}$ of the assembly of two sections in derivation is equal to:

$$\mathbf{b}_{s,SN} = \mathbf{b}_{s,1} + \mathbf{b}_{s,2} \quad (42)$$

whereas, for two sections in series it is equal to:

$$\mathbf{b}_{s,SN} = \min (\mathbf{b}_{s,1}, \mathbf{b}_{s,2}) \quad (43)$$

It should be mentioned that in the case of a terminal section with a head in excess at its downstream end ($H_j > H_{j,min}$), the value of $\mathbf{b}_{s,SN}$ which is used in the process is equal to zero as long as the excess head prevails.

The magnitude of $dH_{i,r}$, for each iteration i and configuration r , is determined as:

$$dH_{i,r} = \min (EH_i, \Delta Y_i, \Delta Z_i) \quad (44)$$

where:

EH_i is the minimum value of the excess head prevailing in all the nodes where the head will change;

ΔY_i is the minimum value of $(Y_{ki} - Y^*)$ for those sections that change in diameter, with $Y_{k,i}$ being the value of the head loss in the section k at iteration i , and Y^* is, for this section, the value of the head loss corresponding to the largest diameter over its entire length if the section has two diameters, or the next greater diameter if the section has only one diameter. Note that for those terminal sections with head in excess ($H_j > H_{j,min}$), ΔY_i is equal to the value of this excess ($H_j - H_{j,min}$).

ΔZ_i is the difference between the upstream piezometric elevation, $(Z_0)_{i,r_1}$, at iteration i when the flow regime r_1 occurs, and the piezometric elevation, Z_0 , effectively available at the upstream end of the network.

The iterative process is continued until Z_0 is reached, obtaining the optimal solution for the examined configuration, r_i . This solution is considered as the initial solution for the next configuration (r_2) and the iterative process is repeated. The process is continued until all the discharge configurations, C , have been considered. Diameters of the sections can only increase or remain constant for the previous analysed configurations to be satisfied. The final optimal solution should satisfy all the examined discharge configurations.

A computer program for calculating the optimal pipe size of an irrigation network under both several discharge configurations and in case of single flow regime has been developed (Lamaddalena, 1997) and integrated into the COPAM package. The ELIDM has been validated using the linear programming formulation extended for several flow regimes (Ben Abdellah, 1995; Lamaddalena, 1997). The commercial computer package (LINDO) was adapted for calculating the optimal solution for the irrigation network with linear programming.

Darcy's equation was used in ELIDM for calculating the friction slope J [m m^{-1}] in the pipes:

$$J = 0.000857 (1 + 2\gamma D^{-0.5})^2 Q^2 D^{-5} = u Q^2 \quad (45)$$

where γ is the roughness parameter of Bazin, expressed in $\text{m}^{0.5}$. The other variables have been already defined in the text. In Table 4 the values of the roughness Bazin parameters for different types of pipes are reported. They are compared with the values of the equivalent homogeneous roughness ϵ (mm). Information on the different types of pipes is reported in Annex 2.

TABLE 4
Bazin roughness parameter (γ) for different types of pipes

TYPE OF PIPE	Equivalent homogenous roughness ϵ (mm)	γ ($\text{m}^{0.5}$)
1- Technically smooth tubes (glass, brass, drawn copper, resin)	0 ÷ 0.02	--
2- Steel pipes		
A) Time degradable coverings		
- New pipes, varnished by centrifugation	0.05	--
- Bitumened by immersion	0.1 ÷ 0.015	≤ 0.06
- In current duty with light rust	0.2 ÷ 0.4	0.10
- With asphalt or tar applied by hands	0.5 ÷ 0.6	0.16
- With diffused tubercolisation	1 ÷ 3	0.23
B) Non degradable coverings		
- Cement applied by centrifugation	0.05 ÷ 0.15	≤ 0.06
3- Welded sheet-pipes		
- In good conditions	0.2 ÷ 0.3	0.10
- In current duty with crusting	0.4 ÷ 1.0	0.16
4- Nailed sheet-pipes		
- 1 line of longitudinal nails	0.3 ÷ 0.4	0.10
- 2 lines of longitudinal nails	0.6 ÷ 0.7	0.16
- Idem with crusting	1 till 3.0	0.30
- 4-6 lines of longitudinal nails	2.0	0.23
- 6 lines of longitudinal nails + 4 transversal	3.0	0.30
- Idem with crusting	1 till 5.0	0.36
5- Cast iron pipes		
- With centrifuged-cemented covering	0.1	≤ 0.06
- New, covered internally with bitumen	0.15	0.06
- New, not covered	0.2 ÷ 0.4	0.10
- With light crusting	0.4 ÷ 1.0	0.16
- In current duty, partially rusted	1.0 ÷ 2.0	0.23
- strongly encrusted	3.0 ÷ 5.0	0.36
6- Cement-pipes		
- Asbestos cement	0.1	≤ 0.06
- New reinforced concrete, plaster perfectly smooth	0.1 ÷ 0.15	0.06
- Reinforced concrete with smooth plaster, in work for many years	2.0	0.23
- Tunnels with cement plaster, depending on the degree of finish	2.0 ÷ 5.0	0.23 ÷ 0.36

The applicability of the ELIDM in the case of a network with SFR is presented in the next section.

Applicability

In this section, the applicability of the Labye iterative discontinuous method has been verified through the linear programming formulation. Both the methods have been applied to a network under several flow regimes.

The RGM presented in chapter 3 was previously used for generating different sets of random discharge configurations. These sets of configurations have been utilized for the calculation of the optimal diameters using the ELP and ELIDM programs.

The difference in cost of the network under study is shown in Figure 34. It is always less than 2% because in the ELP formulation all the discharge configurations are considered as a unique block and, thus, the exact solution is obtained. In the ELIDM program the configurations are considered one by one, with the final solution for the configuration r_i being the initial solution for the r_{i+1} configuration. Therefore, diameters of the sections can only increase or remain constant when the configurations change. For this reason, the order of the discharge configurations during the calculation has little effect on the optimal solution.

The differences between the ELP and the ELIDM are small. When several discharge configurations are considered, the latter method is preferred because it is more flexible and the computation time is very short (a few seconds for each discharge configuration). Furthermore, the computer software integrated in the COPAM package is user-friendly and allows the calculation of networks up to 1000 nodes under more than 1000 flow regimes.

THE INFLUENCE OF THE PUMPING STATION ON THE PIPE SIZE COMPUTATION

The basic relationship between the pumping station at the upstream end of an irrigation system and the pipe network is that the higher upstream pressure the lower the diameters of the network, and vice versa. The other important relationship is that the higher the pressure the higher the costs of the pumping station and the energy.

Through the optimization programs we can compute the variation of the network costs for different upstream piezometric elevations "z". On the other hand, the piezometric elevation can be translated into energy and pumping station costs. The total cost for the irrigation system (network, pumping station and energy) is given by the sum of both costs. The total cost is represented by a curve having a minimum value corresponding to an optimal solution (Figure 35). It is understood that all costs must be referred to the same life span and therefore must be actualized.

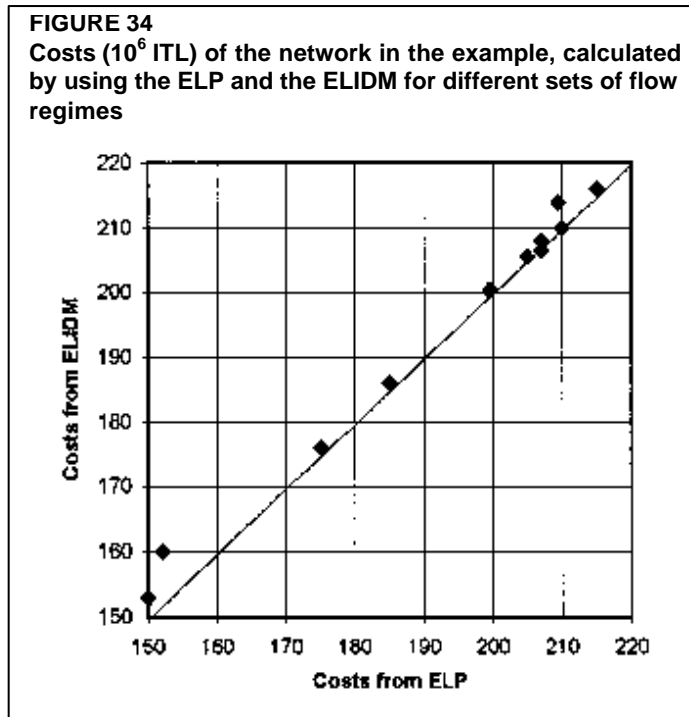

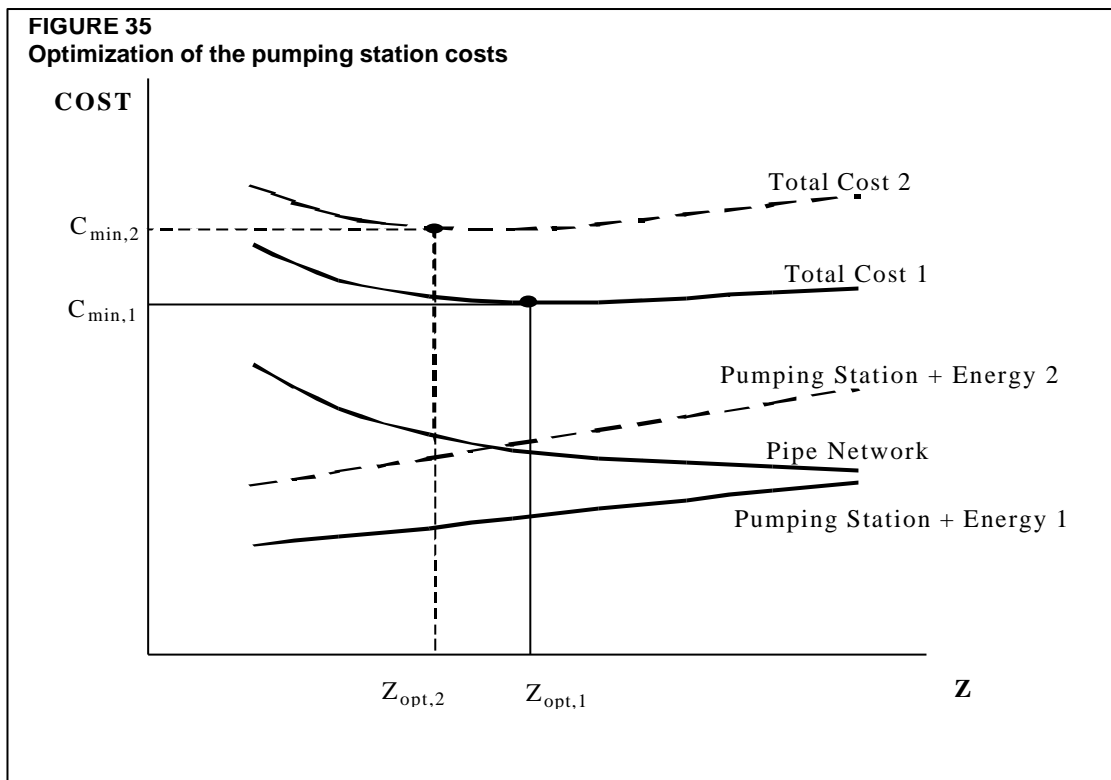

Notwithstanding the correctness of this mathematical approach, a practical limitation should be highlighted concerning the uncertainty in the energy cost evolution. In fact, there are examples of pumping stations that were designed when energy costs were relatively low (before the petrol crisis) and at that time an optimal upstream piezometric elevation was found that nowadays it is not economical and causes very high water fees (Figure 35).

According to these considerations, the designer should use the optimization procedures with a critical view. For this reason the automatic optimization of the upstream piezometric elevation has not been included in COPAM. Nevertheless COPAM gives the possibility to compute the optimal cost of the network for several piezometric elevations but each one has to be computed one by one. The designer can use these results to evaluate different pumping station alternatives taking into account that related costs can only be estimated, in a reliable way, under present conditions.

THE USE OF COPAM FOR PIPE SIZE COMPUTATION

The use of the optimization program integrated in the COPAM package is easy. After completing the input file, as described in the chapter 3, by clicking on the “Optimization” button (Figure 36) the page control in Figure 37 will appear on the screen.

Three alternatives are available within the “Options” Tab control, concerning the flow regimes (Figure 37): single flow regimes, several flow regimes directly generated by the program, and several flow regimes previously generated and stored in a file to be read. The last option allows network optimization also in the case of rotation delivery schedule. In fact, the flow regimes are computed according to the planned irrigation schedule and stored in a file that will be read by the program. Concerning the option “single flow regimes”, the program allows the computation of discharges by using the 1st or 2nd Clément model.

FIGURE 36
Pipe size computation program

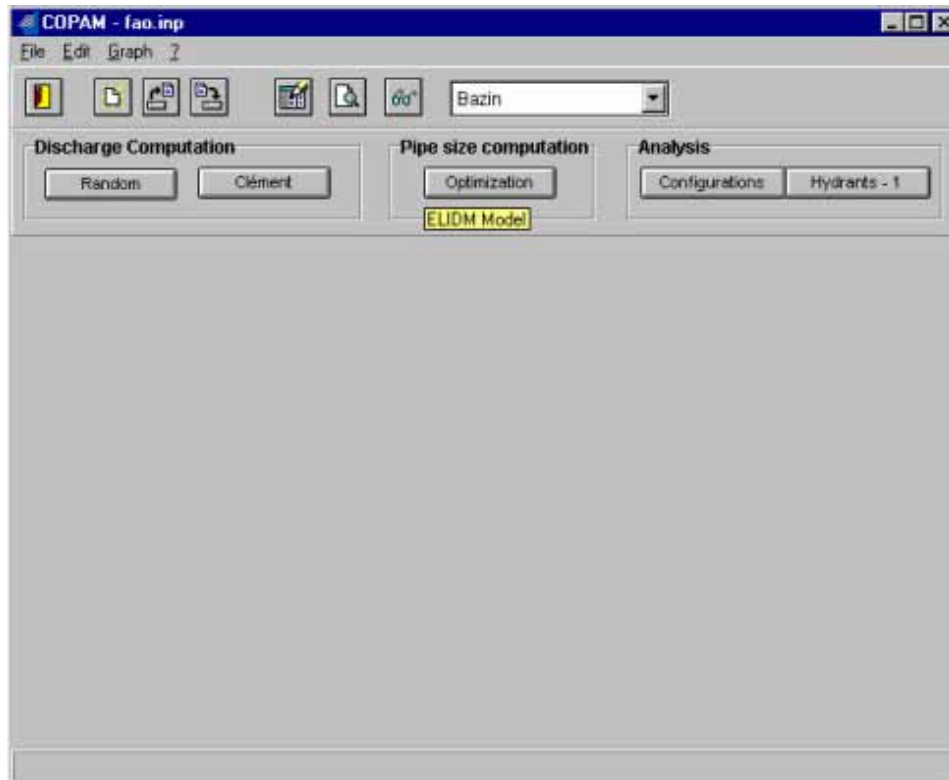
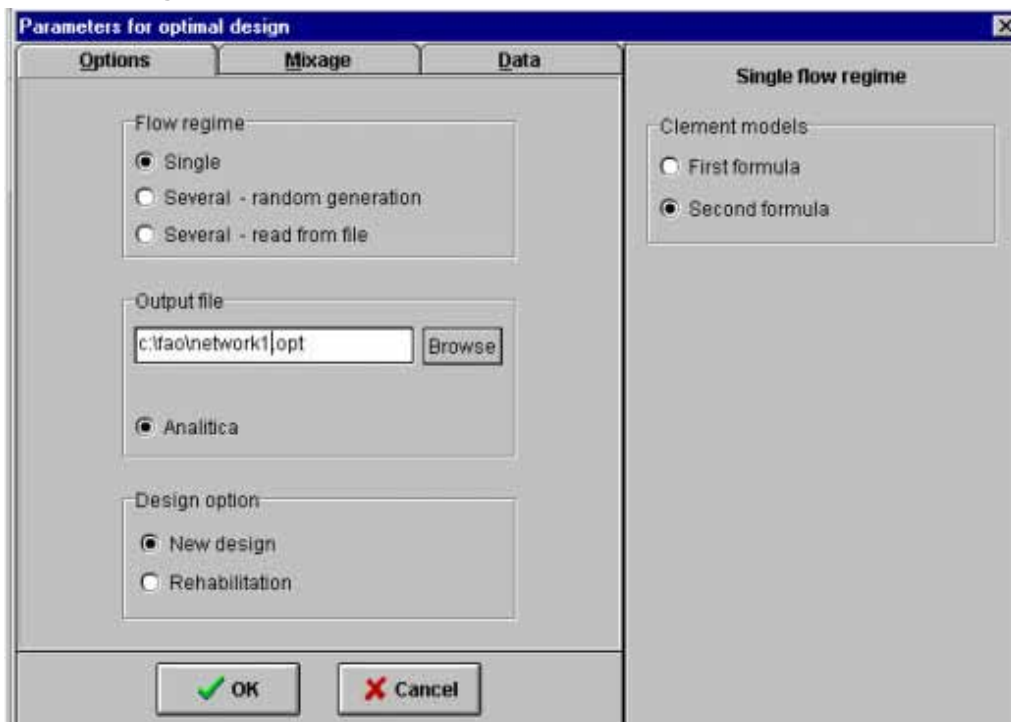
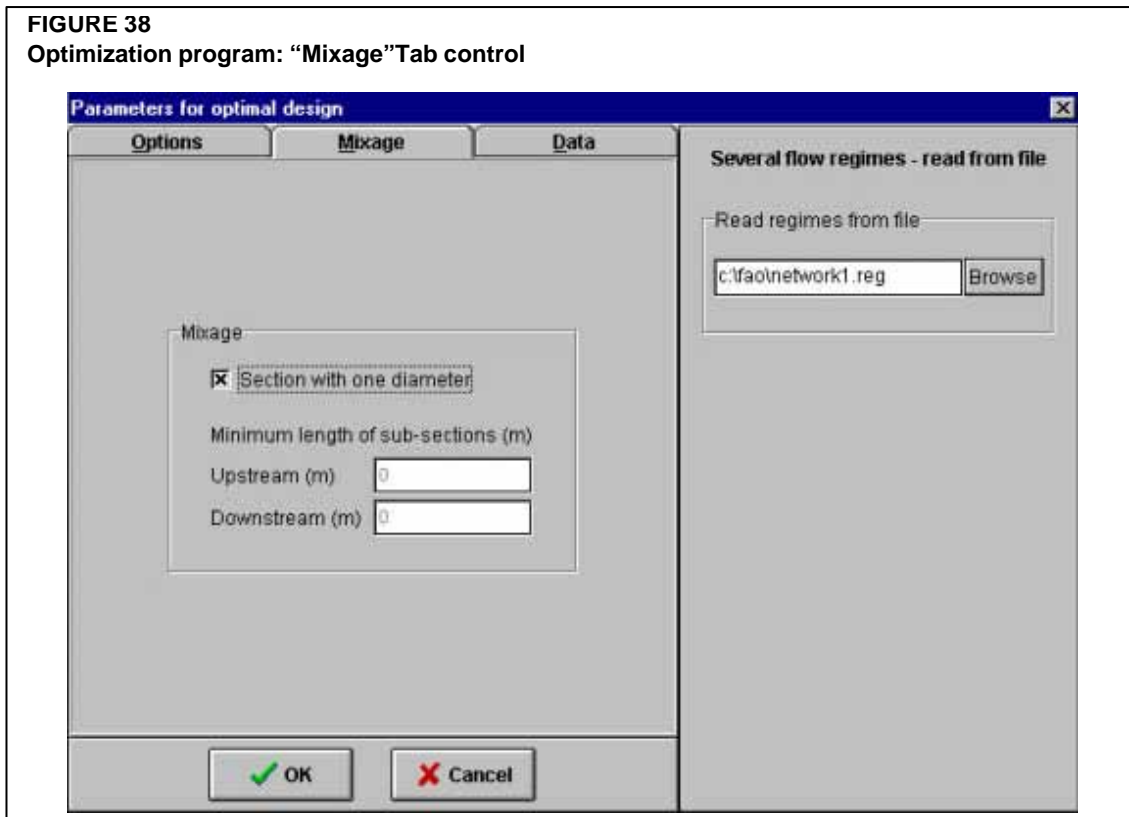

FIGURE 37
Optimization program: "Options" Tab control





The name of the output file is typed in the appropriate edit box. The extension “.opt” is automatically assigned to this output file. All information concerning the computation is stored in that file (see the example of the output file in Annex 3). Finally, two additional design options are available in the program: new design and rehabilitation. In the first case, the program computes the optimal pipe size diameters starting from an initial solution obtained by using the smallest diameters respecting the maximum flow velocities constraints (as explained in the chapter 4). In the case of rehabilitation, the initial solution is given by the actual diameters of each section of the network.

The program, within the “Mixage” tab control (Figure 38), gives the possibility to select one diameter for each section or to consider the mixage with two diameters for each section where required. From a practical point of view, one diameter should be selected in order to avoid possible mistakes during the construction phase.

In the “Data” Tab control (Figure 39), all the parameters related to the 1st or 2nd Clément formula are introduced. These parameters were illustrated in chapter 3. The upstream piezometric elevation and the minimum pressure head required at the hydrants are typed in the appropriate edit boxes.

The software allows also the computation of the optimal pipe size diameters when the minimum pressure head at the hydrants is not a constant. In this case, the radio button “variable” is selected and, in the last column of the input file, the appropriate minimum pressure heads (H_{\min}) are typed in correspondence of each hydrant (Figure 40).

FIGURE 39
Optimization program: "Data" Tab control

Parameters for optimal design

Options **Mixage** **Data**

Minimum head at hydrants (m)

Constant

Variable

Upstream piezometric elevation (m a.s.l.)

Additional data

Specific continuous discharge (l/s*ha)

Number of terminal open hydrants

Uncultivated land

Clement use coefficient (r)

Operation quality (Up)

Single flow regime

Clement models

First formula

Second formula

OK Cancel

FIGURE 40
Input file: Edit network layout

EDIT network layout

Final node	Area (ha)	Hydrant disch. (l/s)	Section length (m)	Land elevation (m a.s.l.)	Diameter (mm)	Hmin hydrants (m)
1	0.00	0.0	500.00	102.00	1200	25.00
2	0.00	0.0	775.00	102.00	800	25.00
3	0.00	0.0	375.00	102.00	800	25.00
4	0.00	0.0	425.00	102.00	800	30.00
5	0.00	0.0	775.00	88.00	700	30.00
6	0.00	0.0	1000.00	94.00	700	30.00
7	0.00	0.0	950.00	74.00	700	30.00
8	0.00	0.0	5.00	74.00	700	35.00
9	0.00	0.0	650.00	70.00	700	35.00

+ Add Node - Canc Node + Ins Node End section Exit

Section 11 of 903

FIGURE 41
Optimization program: “Options” Tab control

When “Several flow regime” is selected within the “Options” Tab control (Figure 41), the final solution or the analytical solution for each flow regime may be printed on the output file by clicking on the appropriate radio button. The name of the output file is typed in the edit box. In this case the final solution is recommended, especially when many flow regimes are generated and the output file might be too long.

When the option “Several flow regimes” is selected, only the upstream piezometric elevation and the minimum pressure head are typed in the appropriate edit boxes in the “Data” Tab control (Figure 42).

In the case of flow regimes generated directly by the program (Option: Several-random generation in Figure 41), the name of the file where the flow regimes are stored needs to be specified in the appropriate box (Figure 41). Also, the maximum upstream discharge and the number of flow regimes to be generated (remember that this number must be multiple of 10) are specified in the appropriate boxes (Figure 41).

These last two inputs are not required when the flow regimes are read from a file (Option: Several-read from file, in Figure 43). Only the name of the file for reading the flow regimes is specified in the appropriate edit box.

Sensitivity analysis of the ELIDM

The actual number of flow regimes in an irrigation network is large and the optimal solution varies according to the number of flow regimes considered (see Figure 34). Consequently, a sensitivity analysis is required to examine the variation of the optimal solution for several sets of flow regimes.

FIGURE 42
Optimization program: "Data" Tab control

Parameters for optimal design

Options | **Mixage** | **Data**

Minimum head at hydrants (m)

Constant 20.0

Variable

Upstream piezometric elevation (m a.s.l.) 128.00

Additional data

Specific continuous discharge (l/(s*ha)) 0.327

Number of terminal open hydrants 4

Uncultivated land 0.00

Clement use coefficient (r) 0.667

Probability of saturation - Pa (%) 1.000

Several flow regimes - random

Write regimes on file

c:\faot\flowregime1.reg Browse

Maximum upstream discharge (l/s) 50

Number of flow regimes to generate 100

OK Cancel

FIGURE 43
Optimization program: "Options" Tab control

Parameters for optimal design

Options | **Mixage** | **Data**

Flow regime

Single

Several - random generation

Several - read from file

Output file

c:\compaq\w\faot\fao.opt Browse

Final solution

Analitica per ogni regime

Design option

New design

Rehabilitation

OK Cancel

esempio di file input per il calcolo di una rete collettiva

FIGURE 44
Layout of the network

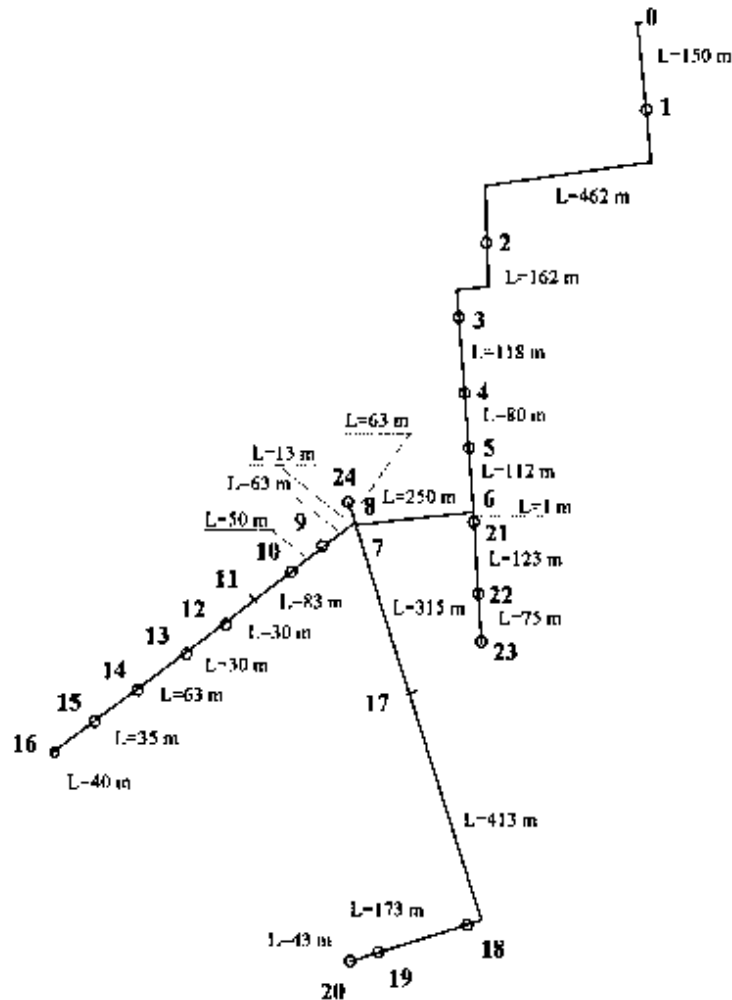

The ELIDM was used for the irrigation network in Figure 44. Fifty different sets of flow regimes, corresponding to 50 l s^{-1} , were randomly generated by the RGM (described in the chapter 3), and used for investigating the sensitivity of the optimal solution versus the number of flow regimes. The input file of the network is reported in the Annex 3, as well as an example of the output file for one random flow regime.

Initially, ten random discharge configurations were generated for calculating the cost $P_{1,10}$. Subsequently, another ten random discharge configurations were generated for calculating the cost $P_{1,10}$, and so on for every $P_{1,10}$ up to a total of 50 sets of flow regimes. This procedure was repeated for an increased number of configurations in each set, from 20 up to 100. Therefore, if C is the number of configurations in each set, varying from 10, 20, ..., 100, the average cost for each C is:

$$\bar{P}_C = \frac{\sum_{i=1}^{50} P_{i,C}}{50} \quad (46)$$

In Figure 45, the average cost of the network and the relative confidence interval at 95% of probability is reported for each set of discharge configurations.

Figure 45 shows that when a larger number of flow regimes is considered a more stable solution is obtained. When the number of flow regimes increases, the designed network is able to satisfy a larger population of possible configurations. Figure 45 also shows that when a larger number of flow regimes is considered, the optimal solution obtained for different repetitions of the same number of flow regimes falls within a narrower range of confidence interval. The results indicate that a minimum of 50 discharge configurations ($C = 50$) is needed for calculating the network in the example.

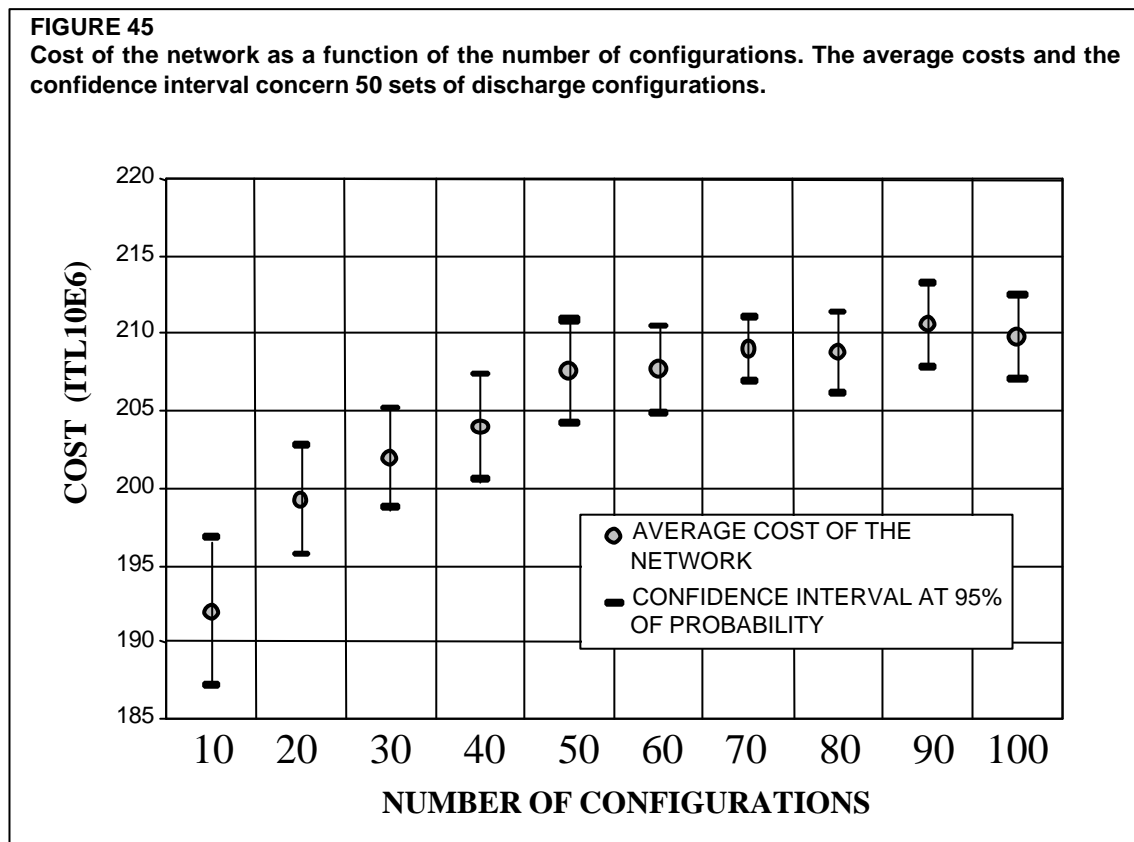

The sensitivity analysis (Figure 45) shows how the cost of the network depends upon the number of flow regimes. Thus, the need to establish criteria for selecting the “most suitable” solution arises. We can define it as a “Satisfactory Solution” instead of an “Optimal Solution. This satisfactory solution is related to performance criteria. In the next chapter, models for the analysis of on-demand irrigation systems and performance indicators are presented and applied.

Chapter 5

Analysis of performance

ANALYSIS OF PRESSURIZED IRRIGATION SYSTEMS OPERATING ON-DEMAND

Introduction

Irrigation systems analysis is the process of using a computer simulation model to analyse performance capabilities and to define the system requirements necessary to meet system design standards for pressure and/or discharge (AWWA, 1989). The most important advantage of computer modelling is that it makes the network analysis feasible. In fact, without computerized techniques, analysis is impractical except for simple systems. Based on a computer model, network analysis is used to determine the adequacy of the existing irrigation systems, to identify the causes of their deficiencies and to develop the most cost-effective improvements.

Network analysis is often used also for improving design techniques. In fact, before the advent of computer system analysis, over-design was the common reaction to account for uncertainties in the design stage. Actually, models for analysis and performance criteria may contribute to support design of new irrigation systems that should be able to operate satisfactorily within a wide range of possible demand scenarios.

In this chapter, two models for the analysis of irrigation systems operating on-demand are illustrated and a discussion on the power and weakness of those models is presented. In particular, the first model provides information on the global performance of the irrigation system, while the second model gives more precise information that allows for determination of the percentage of unsatisfied hydrants, their position and the magnitude of their pressure deficit. Furthermore, mathematical definitions of some performance indicators (i.e. reliability and relative pressure deficit) are formulated to help both the designer and manager in selecting a satisfactory solution.

Indexed characteristic curves

The indexed characteristic curves model (CTGREF, 1979; Bethery *et al.*, 1981; Labye *et al.*, 1983) provides information on the global performance of an on-demand irrigation system. This information may be used for a variety of applications, as described below.

Description of the model

Under the hypothesis that any operating hydrant may deliver the nominal discharge, d [l s^{-1}], even when the pressure head changes (see Figure 46) (usually this is true when the hydrants incorporate a proper flow limiter), let us redefine "configuration" (r) as a group of operating hydrants (j) corresponding to a fixed value of the nominal discharge, Q [l s^{-1}], at the upstream end of the network.

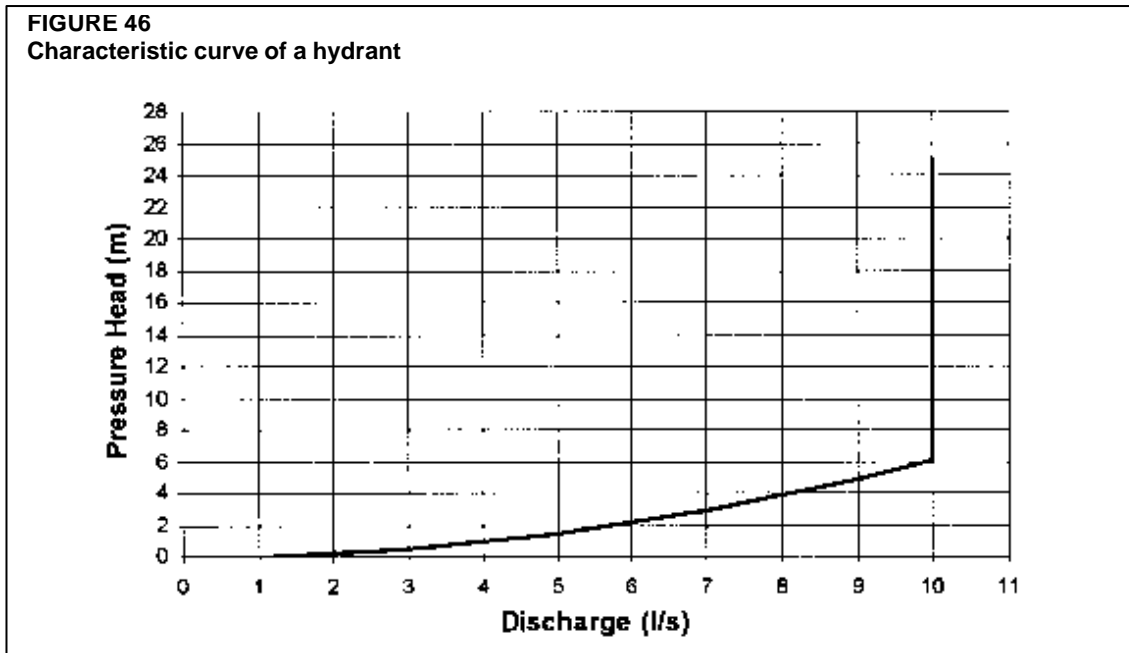

A configuration is satisfied when, for all the operating hydrants of the configuration, the following relationship is respected:

$$(H_j)_r \geq H_{\min} \quad (47)$$

where $(H_j)_r$ [m] represents the hydraulic head of the hydrant j within the configuration r , and H_{\min} [m] represents the minimum required head for appropriate operation of the on-farm system.

For each configuration, the satisfaction of the condition (47) depends on the plano-altimetric location of the operating hydrants. In general, the network is able to satisfy only a percentage of the possible configurations. For any value of the discharge Q flowing in the upstream section of the network, within zero and Q_{\max} (discharge corresponding to the total number of hydrants in operation), different values of the piezometric elevation, Z_r [m a.s.l.], satisfy the relationship (47), each one corresponding to a different hydrant configuration. Therefore, if for all the possible configurations r , the couples (Q_r, Z_r) referred to discharges ranging between 0 and Q_{\max} are calculated, a cloud of points (Figure 47) is observed within an envelope in a plane (Q, Z) . Each point $P_u(Q_r, Z_r)$ of the upper envelope curve gives a piezometric elevation Z_r , at the upstream end of the network, which fully satisfies condition (47) for every discharge Q_r . Each point $P_l(Q_r, Z_r)$ of the lower envelope curve gives a piezometric elevation Z_r for which it is not possible to satisfy the condition (47). In other words, the upper envelope corresponds to 100% of satisfied configurations (relationship 47), while the lower envelope concerns a situation where any configuration is not satisfied (CTGREF, 1979; Bethery *et al.*, 1981; CEMAGREF, 1983; Bethery, 1990).

It is then possible to obtain other curves, between these two envelopes (i.e. indexed characteristic curves) that represent a percentage of satisfied configurations.

The complete investigation of all the possible configurations leads to a large number of cases, equal to

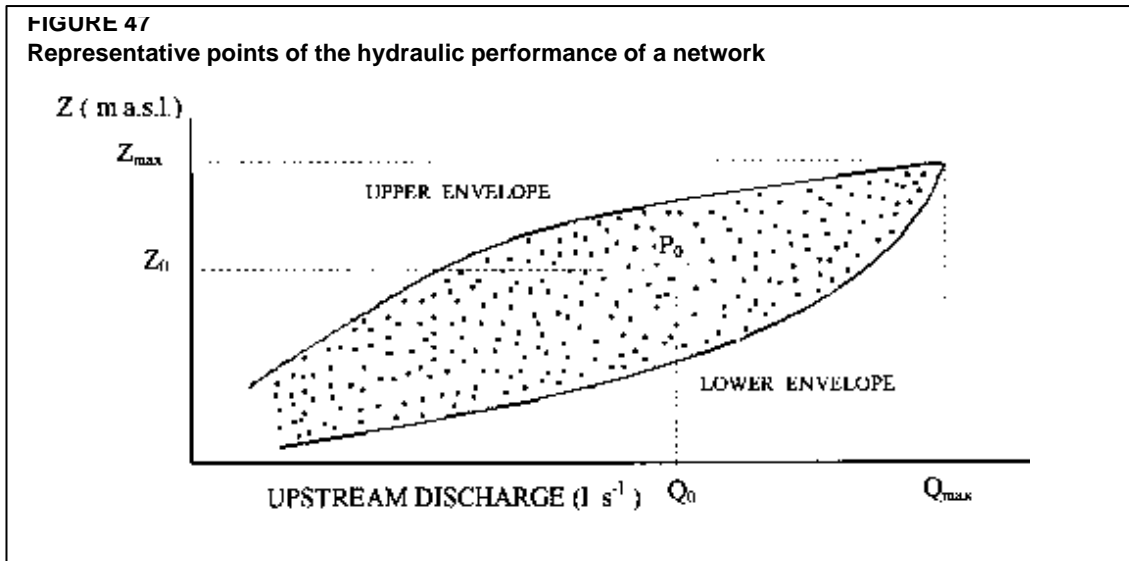

$$C_R^K = \frac{R!}{K!(R-K)!} \quad (48)$$

where C_R^K represents the number of possible configurations when the discharge Q_r is delivered, corresponding to K hydrants simultaneously operating, and R is the total number of hydrants in the network. Therefore, in order to calculate the indexed characteristic curves, an equivalent model is used that reduces the number of cases investigated.

One can establish a given discrete number of discharges where each of them corresponding to a number, K , of simultaneously open hydrants:

$$K = Q_r/d \quad (49)$$

This assumes that all the hydrants have the same nominal discharge, d ¹.

The number C of configurations to be investigated for each discharge should be close to the total number of hydrants (R) according to the results obtained by Bethery (1990). Therefore, once C is known, a generator of random numbers, having uniform probability distribution, is used. Thus, the K hydrants for each configuration are drawn in the range between 1 and R .

¹ In the case of different hydrant discharges, the number of hydrants simultaneously opened will vary as a function of the classes of hydrants drawn. In this case, random drawing will be performed to satisfy the relationship:

$$|Q_{tir} - Q_i| < \epsilon_\tau$$

where Q_{tir} [$l s^{-1}$] is the discharge corresponding to K hydrants drawn at random, and ϵ_τ is the accepted tolerance. In general, ϵ_τ is assumed as equal to the value of the lowest hydrant discharge (Bethery *et al.*, 1981).

FIGURE 48
Characteristic curves program

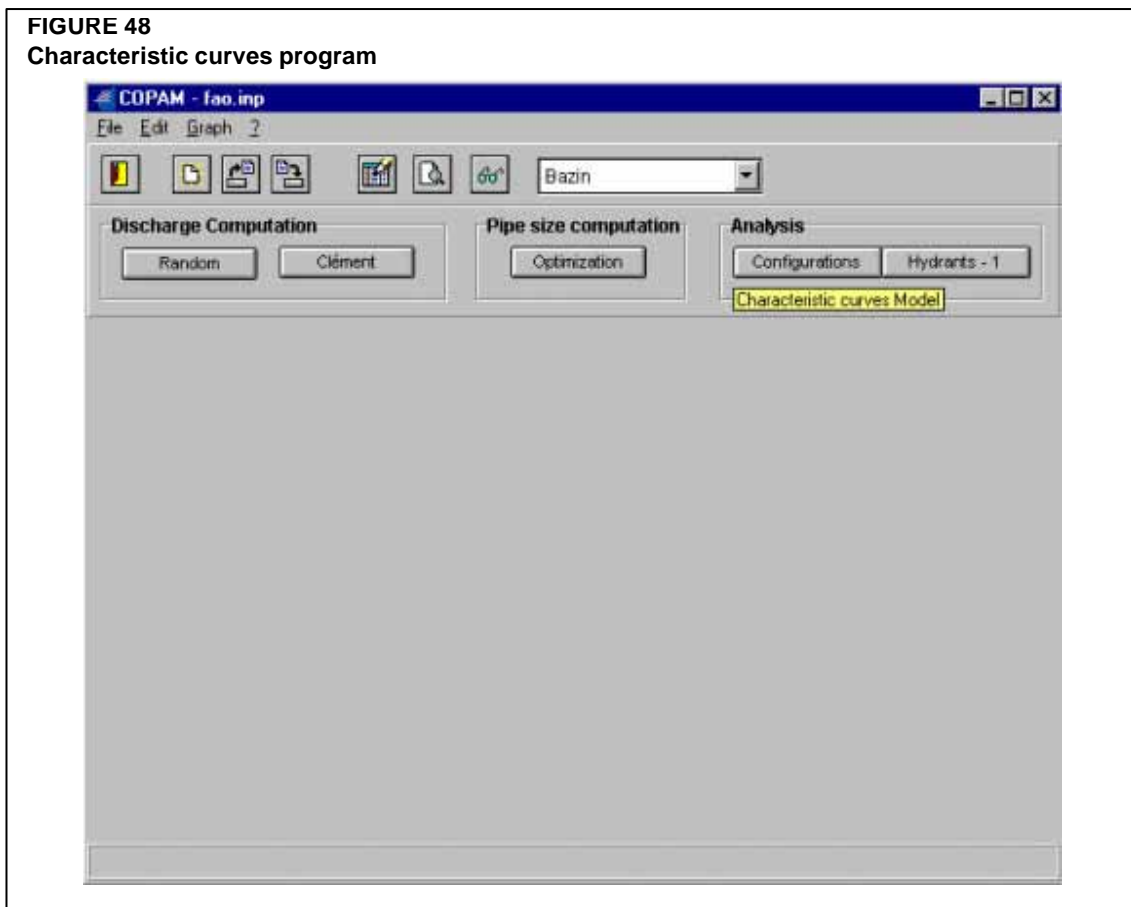

When testing the network under steady flow conditions, it is possible to associate a piezometric elevation at the upstream end of the network to each discharge configuration, such that it satisfies relationship (47). Once the C configurations are investigated, a series of piezometric elevations (Z_r) at the upstream end of the network is associated to each discharge Q_r , so that each one represents the piezometric elevation able to satisfy a given percentage of C configurations.

The indexed characteristic curves are drawn by plotting, in the plane (Q, Z) , the discharge values chosen and the corresponding vectors, as well as by joining the points having the same percentage of configurations satisfied. The shape of these curves depends on the geometry of the network and on the topography of the area to be irrigated. Therefore, indexed characteristic curves with smooth or steep slope are obtained.

Let Z_0 [m a.s.l.] be the design piezometric elevation at the upstream end of the network and Q_0 [l s^{-1}] be the upstream design discharge. Let us define $P_0(Q_0, Z_0)$ as the "set-point" of the network. The performance of the network is then associated to the percentage of satisfied configurations corresponding to the coordinates of the set-point.

The indexed characteristic curves provide information on the global performance of irrigation systems. Nevertheless, the above indexed characteristic curves are drawn following the principle that a configuration is said to be unsatisfied even if the head H_j of one hydrant only is lower than the minimum required H_{\min} . Therefore, if the set-point (Q_0, Z_0) falls on an indexed characteristic curve corresponding to a low percentage of satisfied configurations, then the model is not able to give a precise evaluation of the performance of the network. Consequently,

a new model was formulated to give a more precise picture of the behaviour of the network. It is reported in the next sections.

A software package generating the indexed characteristic curves is available at the CEMAGREF (France) and it may be coupled with the software XERXES-RENFORS (CEMAGREF, 1990), which was reported in chapter 4. An alternative software for computing the indexed characteristic curves is integrated in the COPAM package (see Figure 48). It is used in the applications presented below. The Darcy equation was used for computing the head losses¹, Y [m], in the network:

$$Y = 0.000857 (1 + 2\gamma D^{0.5})^2 Q^2 D^5 L = u Q^2 L \quad (50)$$

where γ is the roughness parameter of Bazin, expressed in $m^{0.5}$, Q [$m^3 s^{-1}$] is the discharge flowing in the pipe, u [$m^{-1} s^2$] is the dimensional coefficient of resistance and L [m] is the length of the pipe.

By clicking on the button program “Configuration”, Figure 49 will appear on the computer screen.

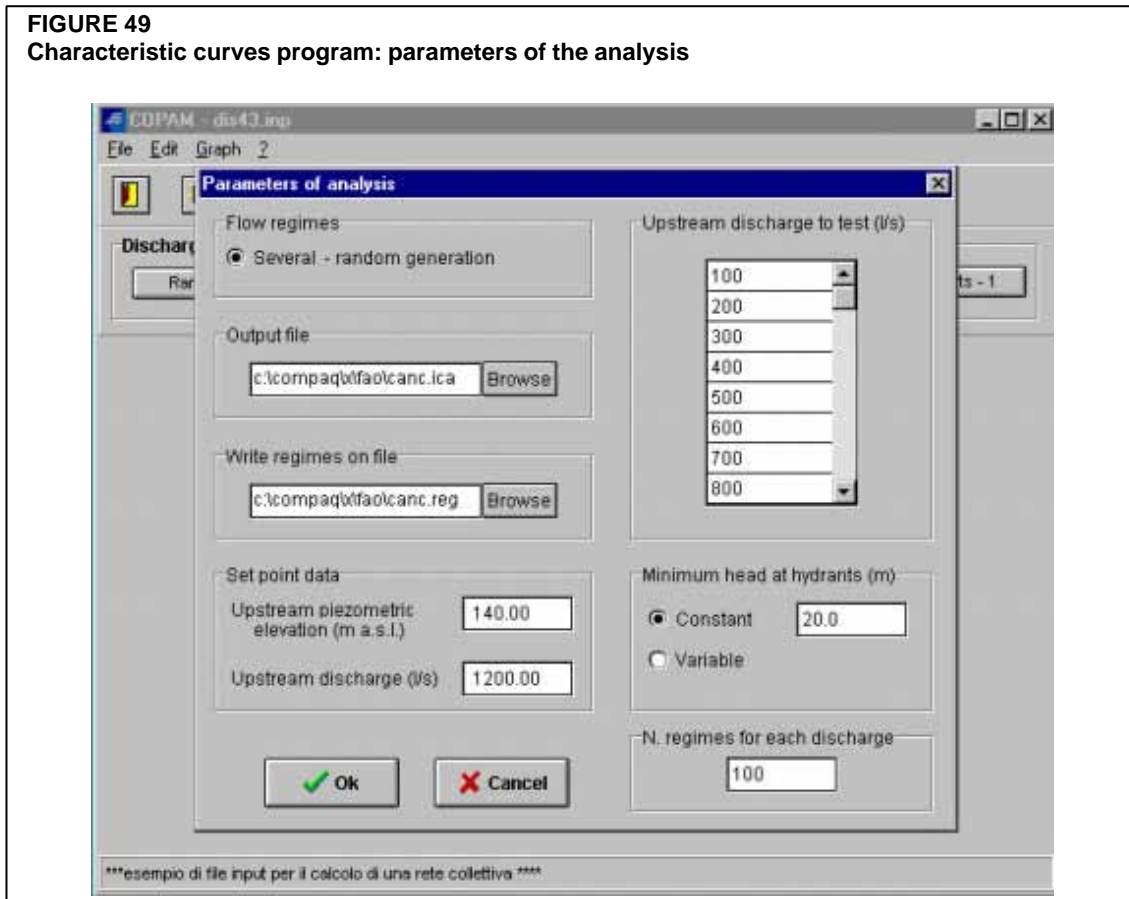

¹ Local head losses have been neglected in the computations. Usually they are very small respect to the linear head losses, anyway they may be taken into account when the upstream piezometric elevation is analysed.

FIGURE 50
Input file: edit network layout

Final node	Area (ha)	Hydrant disch. (l/s)	Section length (m)	Land elevation (m a.s.l.)	Diameter (mm)	Hmin hydrants (m)
1	0.00	0.0	500.00	102.00	1200	25.00
2	0.00	0.0	775.00	102.00	800	25.00
3	0.00	0.0	375.00	102.00	800	25.00
4	0.00	0.0	425.00	102.00	800	30.00
5	0.00	0.0	775.00	88.00	700	30.00
6	0.00	0.0	1000.00	94.00	700	30.00
7	0.00	0.0	950.00	74.00	700	30.00
8	0.00	0.0	5.00	74.00	700	35.00
9	0.00	0.0	850.00	70.00	700	35.00

FIGURE 51
Graph menu bar and sub-menu items

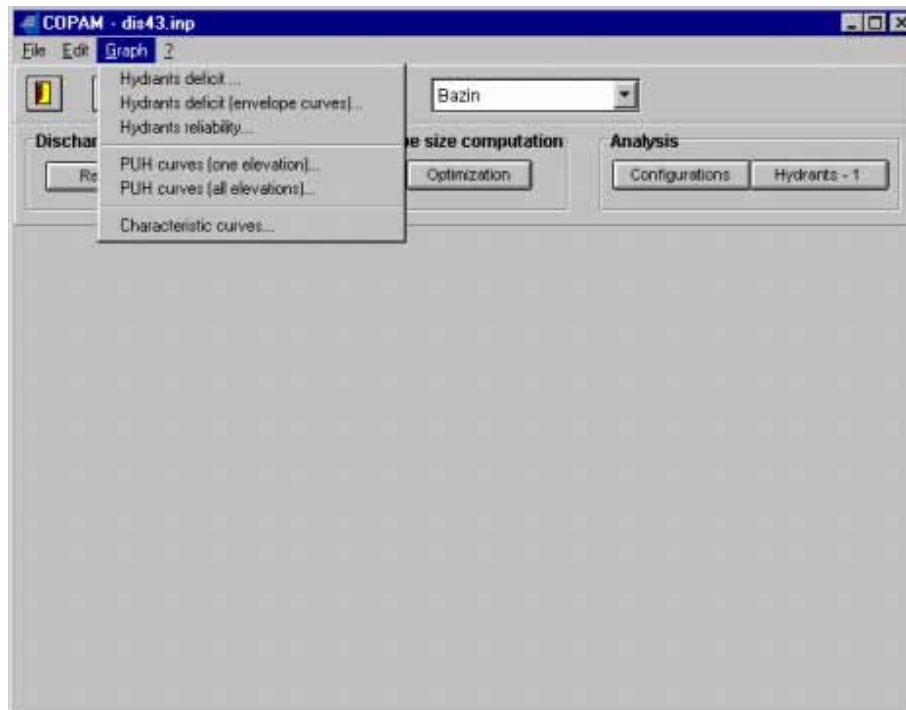

FIGURE 52
Open file to print the characteristic curves



The name of the output file is typed in the appropriate edit box. The extension “.ica” is automatically assigned by the program. The name of the file for storage of the random generated flow regimes has the extension “.ran” automatically assigned. The piezometric elevation (in m a.s.l.) available at the upstream end of the network, and the design upstream discharge (in $l\ s^{-1}$) are written in the “set point data” option. The list of discharges to be tested, flowing at the upstream end of the network, is inserted in the appropriate box, as well as the number of regimes to generate for each discharge. Finally, the program allows the computations where the minimum pressure head (H_{min}) required for an appropriate on-farm irrigation is constant or variable. In the first case, the radio button “Constant” is selected in the frame “Minimum head at the hydrants” and the value H_{min} is written in the appropriate box. In the other case, the radio button “Variable” is selected and the values of the minimum head at each hydrant are inserted in the last column of the input file (see Figure 50).

The COPAM package has an easy graphical interface. It prints the characteristic curves of the network by clicking on the “Graph” menu bar and then on the “Characteristic curves ...” which is a sub-menu item (Figure 51). The name of the output file (with extension “.ica”) is selected for printing the graphic (Figure 52).

Two different analysis are reported in the next sections:

- the first is for an irrigation system under design;
- the second is for an existing irrigation system.

Application 1: Network under design, served by an upstream pumping station

This section describes the application of the indexed characteristic curves model to an irrigation network supplied by a pumping station equipped with variable speed pumps (Lamaddalena and Piccinni, 1993)¹. The example shows the wide applicability of the model during the design stage.

The irrigation network serves an irrigable area of 582 ha equipped with 175 hydrants out of which 129 with nominal discharges of 5 l s^{-1} , 22 hydrants of 10 l s^{-1} and 24 hydrants of 20 l s^{-1} . It was designed for on-demand operation. The area is upsloping towards the origin of the network, with elevations ranging from 15 m a.s.l. to about 24 m a.s.l. The lifting plant is designed for a maximum discharge of 325 l s^{-1} (calculated with the first Clément model) with an upstream piezometric elevation $Z_0 = 66.7 \text{ m a.s.l.}$ The total head of the lifting plant is $H_{PS} = 62 \text{ m}$ (since the land elevation of the pumping station is $Z_{TPS} = 2.7 \text{ m a.s.l.}$, and the head losses within the pumping station are $Y_{PS} = 2.0 \text{ m}$). The minimum design head at each hydrant (H_{min}) is 25 m, aiming at low pressure sprinkler or trickle irrigation methods. Downstream of the pumping station, a flow meter, a pressure meter and an inverter are installed. The inverter serves to modify the rotation speed of a pump by changing the input frequency (50 Mhz standard). It is controlled by a computer which receives information on the discharge and head from the flow and pressure meters.

The indexed characteristic curves are represented in figure 53. They were drawn using 200 random configurations of hydrants corresponding to upstream discharges Q_r between 10 and 600 l s^{-1} . The figure shows that the set-point P_0 (325, 66.7) falls on the indexed curve of 93%. This means that the head at the hydrants is higher than the minimum required in 93% of all the examined discharge configurations. Indeed, the performance of this system, as defined by this model, is 93%. In this case, the application of the model will save energy at the pumping station since it is equipped with variable speed pumps (Lamaddalena and Piccinni, 1993).

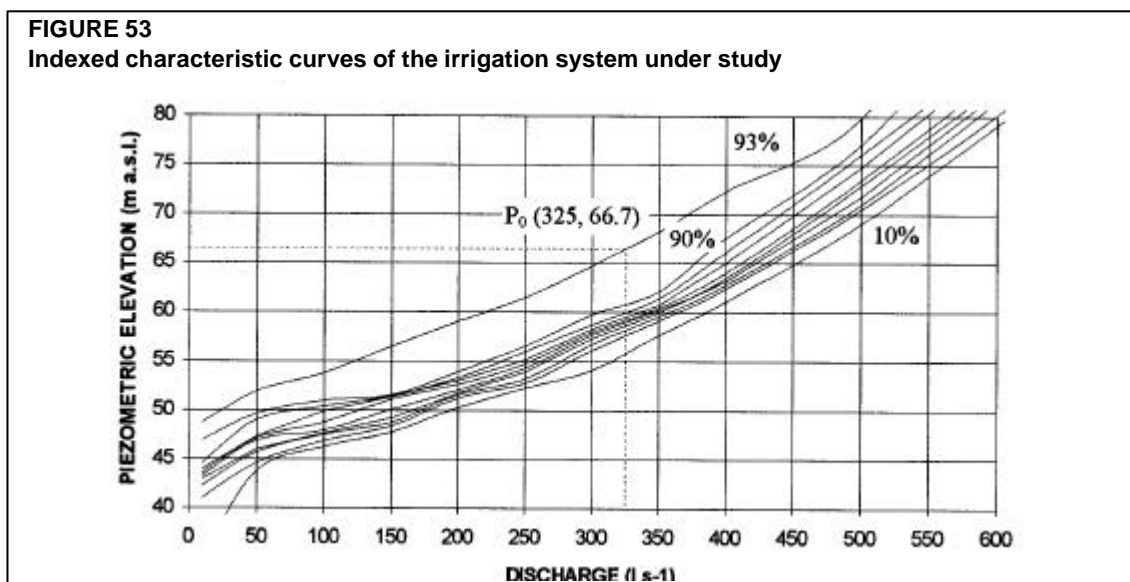

¹ Several types of pumping stations are available in practice, in addition to the variable speed pumps presented in this section. For more information, FAO I&D Paper 44 is suggested to the readers.

From Figure 53, when the discharge decreases from 325 l s^{-1} to 10 l s^{-1} , the same percentage of configurations (93%) may be satisfied when the upstream piezometric elevation decreases from 66.5 m to 52.7 m, or with heads from 62 m to 48 m. Because the lifting station is equipped with variable speed pumps, it is possible to adjust the head of the pumps according to the indexed characteristic curve. Indeed, when discharges are lower than 325 l s^{-1} , the head H_{PS} of the pumping station may decrease with consequent energy saving.

The pumping plant is equipped with five horizontal electric pumps, each designed for a discharge of 65 l s^{-1} , for $H_{PS} = 62 \text{ m}$, at 1480 rpm. A smaller pump with a discharge of 20 l s^{-1} , for the same head, completes the pumping station. A scheme of a pumping station equipped with variable speed pumps is reported in Figure 54. The characteristic curves of the pumps when operating in parallel are shown in Figure 55.

The small pump operates up to a discharge of about 30 l s^{-1} to compensate for the low efficiency which would result if one of the main pumps operates at low discharge. As the demand in the irrigation network increases, the pressure head drops to the minimum pre-established head for the operation of the small pump ($H=52.0 \text{ m}$ as shown in Figure 55). Then the inverter will cause the first main pump to operate automatically at the lowest speed. With further increase of the discharge in the network, the speed of that pump will increase up to the maximum value of 1480 rpm. Successive increases of the demand induce the operation of a successive pump, first at low speed and finally at the highest speed.

As for the required power, with 1300 rpm the plant can supply a discharge of 50 l s^{-1} with a head of 48.9 m, an efficiency of 74.5% and requiring 32.2 kW. If a full speed electrical pump were started at 1480 rpm (to maintain the head at 62.0 m), 50 l s^{-1} would require 40.0 kW. The resulting energy saving is about 21%. Further comparisons are reported in Table 5, where the power required by the plant equipped with variable speed pumps (pumping plant A) is compared with a classical plant (B).

TABLE 5
Comparing the power requirements for a pumping plant equipped with variable speed pumps (type A) and for a classical pumping plant (type B), as a function of the discharges supplied

DISCHARGE (l s^{-1})	PLANT A (Variable speed pumps)				PLANT B		Power Difference (%)
	rpm	Head (m)	Efficiency (%)	Power (KW)	Head (m)	Power (KW)	
50	1300	48.9	74.5	32.2	62.0	40.0	21
75	1350	49.4	81.0	44.8	62.0	56.3	20
90	1400	49.8	81.0	54.3	62.0	67.5	19
115	1480	50.6	77.5	73.6	62.0	90.2	18
175	1480+1400	53.4	79.8	114.8	62.0	133.3	14
200	1480*2	54.3	80.5	132.3	62.0	151.0	12
260	1480*3	57.6	81.5	180.2	62.0	193.9	7
300	1480*4	60.2	80.5	220.0	62.0	226.5	3
325	1480*5	62.0	78.5	251.7	62.0	251.7	0

Differences between pumping plants are reported in Figure 56 as a function of the discharges supplied. Corresponding energy savings are significant for a wide range of discharges. Considering that the maximum design discharge (and consequently the design head) is in fact required for a short time period with respect to the irrigation season, substantial savings are possible during the lifetime of the system.

FIGURE 54
Scheme of a pumping station equipped with variable speed pumps

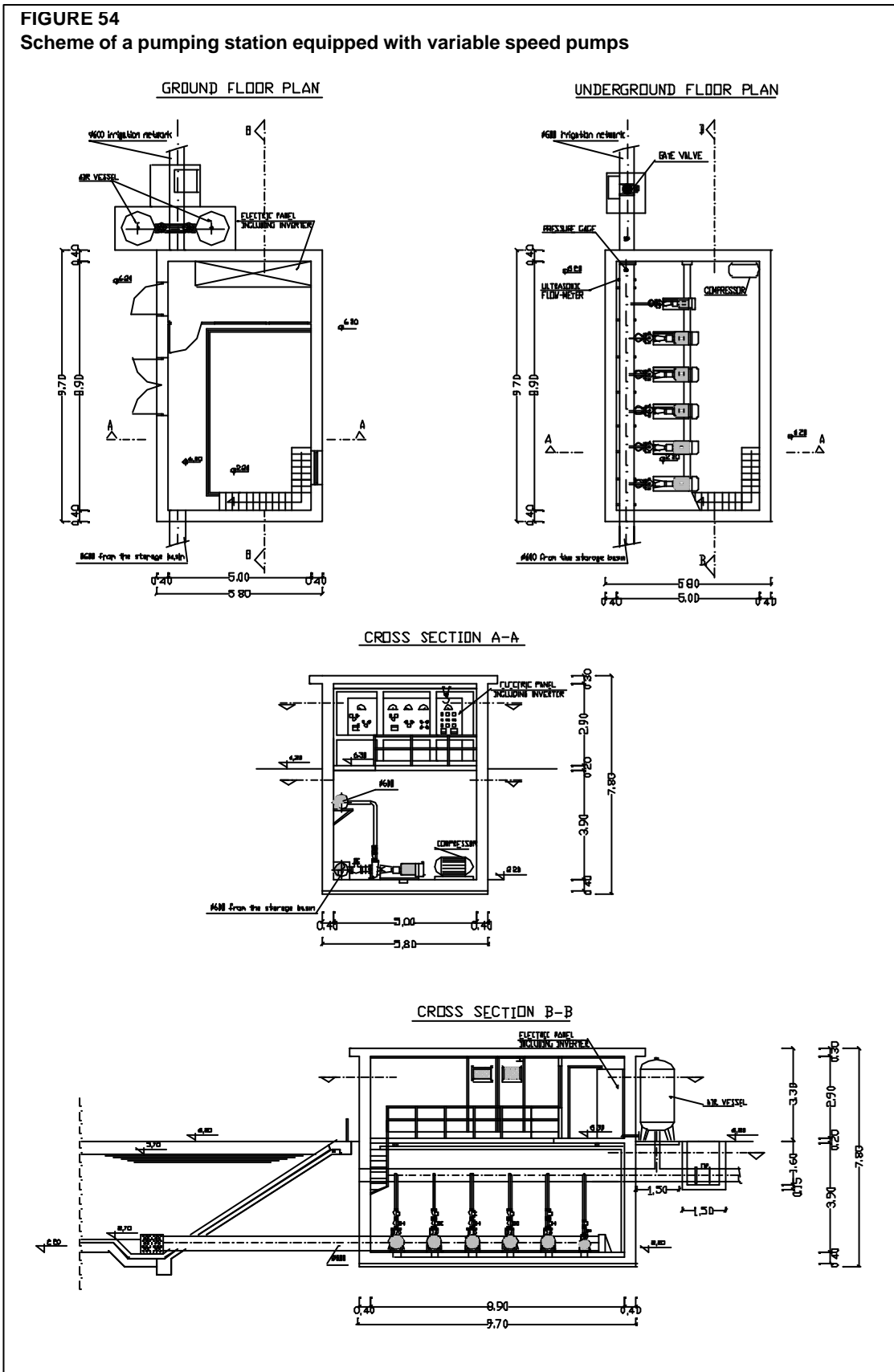

FIGURE 55

Characteristic curves of variable speed pumping station and the 93% indexed characteristic curve of the network. The characteristic curve PP concerns the small pump. The curves 1,2,3,4 and 5 are the characteristic curves resulting from the simultaneous operation of 1,2,3,4 or 5 pumps at 1480 rpm. The dotted lines a,b,c and d concern the modification of those characteristic curves when speed changes to 1440, 1400, 1350 and 1300 rpm respectively.

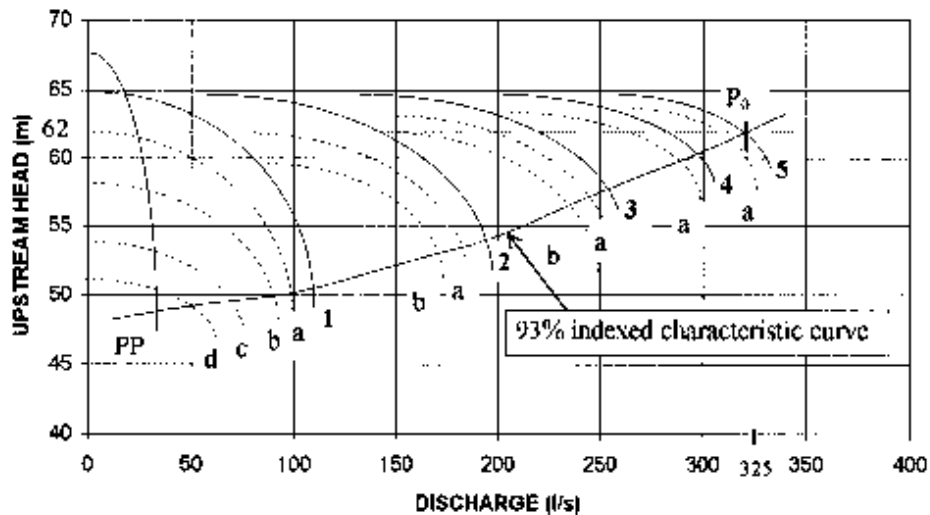
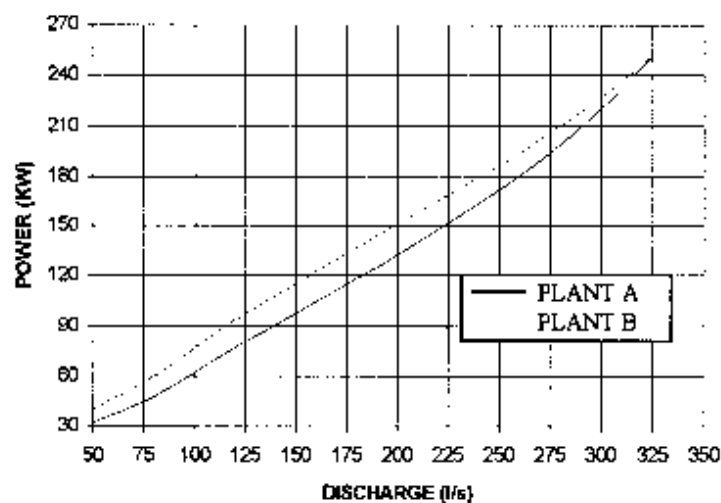

FIGURE 56

Power required by the plant equipped with variable speed pumps (type A) and a classical plant (type B), as a function of the supplied discharges



With the above application, it was shown that the investigation, using the indexed characteristic curves, is an important tool both for testing the hydraulic performance of the network and for designing the associated lifting plants. In the first case, the percentage of satisfied configurations with the variation of the upstream discharge is established and the need to improve the design (or to rehabilitate an existing system) is analysed. In the second case, the investigation is essential to evaluate the need for lifting plants with variable speed pumps, which

could ensure optimal management under the energy point of view. A lifting station equipped with such advanced technologies implies a higher installation cost and a more specialized staff.

Application 2

This irrigation network is located near the town of Lecce (Italy) and serves a total area of 1340 ha. It is equipped with 348 hydrants, out of which 253 of 5 l s^{-1} , 62 of 10 l s^{-1} and 33 of 20 l s^{-1} . It is designed for on-demand operation. The discharges in the network were calculated using the first Clément model, giving a maximum value of 675 l s^{-1} at the upstream end. The upstream piezometric elevation is 81.8 m a.s.l. The minimum head required at each hydrant (H_{\min}) is 25 m, aiming at the low pressure sprinkler and trickle irrigation. The indexed characteristic curves, calculated by the characteristic curves model, are reported in Figure 57.

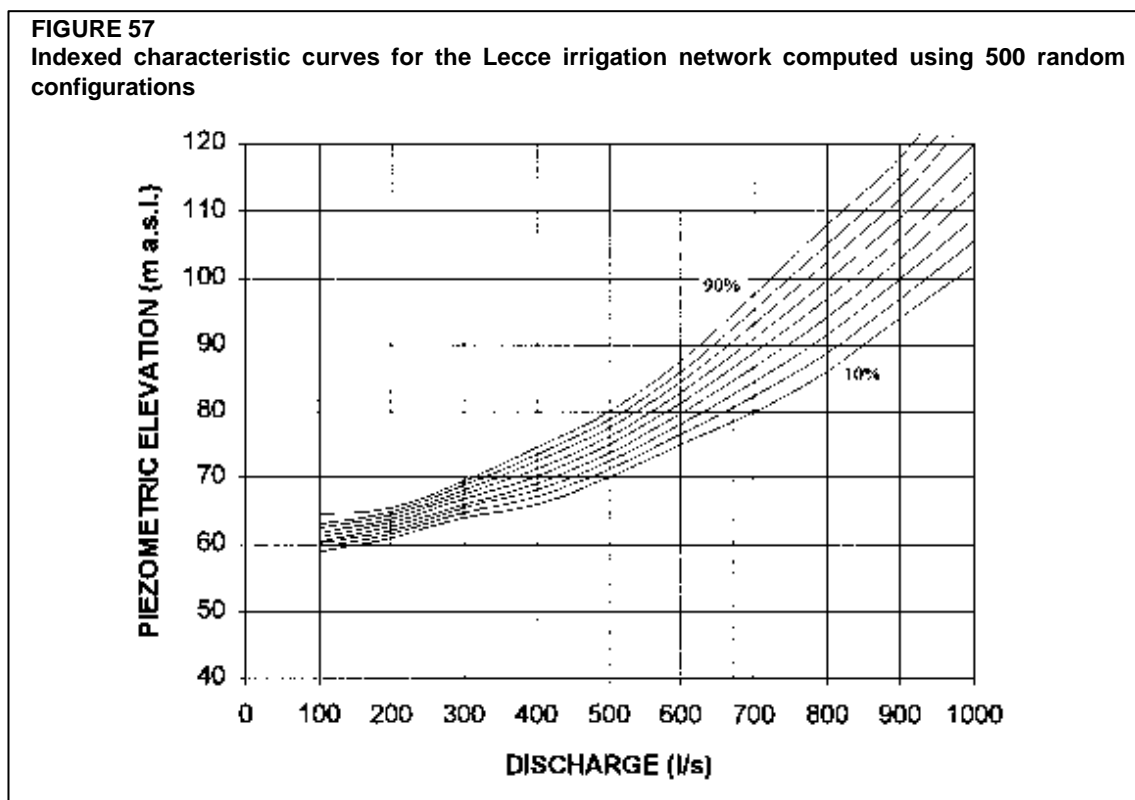

From the characteristic curves, it is observed that the set-point P_0 (675 l s^{-1} , 81.8 m a.s.l.) falls on the characteristic curve of 25%. It means that only 25% of the investigated configurations are fully satisfied, which is a low value.

As mentioned before, the indexed characteristic curves were drawn following the principle that a configuration is said to be unsatisfied even if only one of its hydrant has the head lower than the minimum required. Indeed, especially when the set-point falls on the low percentage characteristic curves (i.e., lower than 50%), a new model is needed for a better evaluation of the system performance and for understanding if any design change is required. This new model, allowing the analysis at the hydrant level, is presented and evaluated in the next section.

Models for the analysis at the hydrant level

The model presented hereafter, called AKLA¹, allows analysis of the pressure head at each hydrant under different operating conditions. This pressure head is compared with the minimum pressure required for an appropriate on-farm irrigation, so a measure of the hydraulic performance for each hydrant is obtained through the computation of the relative pressure deficit defined hereafter. The model is applicable under the hypothesis that the hydrants may deliver a constant discharge for a wide range of operating pressure heads (see Figure 46). This condition is appropriate for a wide range of commercial delivery equipment. Computer software for the model has been developed and integrated in the COPAM package.

The Environmental Protection Agency (EPA) of the United States has also developed a computer program called EPANET (Rossman, 1993) that performs extended period simulation of hydraulic and water quality behaviour within pressurized pipe networks (branched or looped). For this program, also the demand hydrograph at each node is an input data. EPANET tracks the flow of water in each pipe, the pressure at each node, the height of water in each tank and the concentration of a substance throughout the network during a multi-time period simulation. The Windows version of EPANET allows input data to be edited, run the simulator and graphically display its results in a variety of ways on a map of the network. The program can be downloaded from the web site: www.epa.gov/ord/nrmrl/epanet.

Model description

The AKLA model is an improvement of the model described in the previous section. Instead of analysing the whole configurations of hydrants, it permits performance analysis at the level of each hydrant of the network. The model is based on the multiple generation of a pre-fixed number of hydrants simultaneously operating (configuration) using a random number generator having a uniform distribution function (see chapter 3). The computer software has an internal procedure to generate directly the random discharge configurations, or to read the flow regimes from an external file.

Within each generated configuration (r), a hydrant (j) is considered satisfied when the following relationship is verified:

$$H_{j,r} = H_{\min} \quad (51)$$

where $H_{j,r}$ [m] represents the head of the hydrant, j , within the configuration r , and H_{\min} [m] represents the minimum required head for the appropriate operation of the on-farm systems.

The relative pressure deficit at each hydrant is defined as:

$$\Delta H_{j,r} = \frac{H_{j,r} - H_{\min}}{H_{\min}} \quad (52)$$

A flow chart of the AKLA model is presented in Figure 58. The code of the computer program has been written using the language Turbo Pascal Version 6.

¹ This model has been developed by Ait Kadi and Lamaddalena. The first version of the computer program has been available since 1991. It has been utilized for the analysis of several irrigation schemes and reported in M. Sc. Thesis at the CIHEAM., Insitute of Bari (Italy) under the supervision of Proff. Ait Kadi and/or Lamaddalena (Abdelwahab, 1992; El Aallouni, 1993; El Yacoubi, 1994; Ben Abdellah, 1995; Nerilli, 1996; Zaccaria, 1998; Khadra, 1999).

The AKLA model computes the relative pressure deficit at each hydrant and determines the percentage of unsatisfied hydrants. The head losses, Y [m], are computed using the Darcy equation:

$$Y = 0.000857 (1 + 2\gamma D^{0.5})^2 Q^2 D^5 L = u Q^2 L \quad (50)$$

where γ is the roughness parameter of Bazin, expressed in $m^{0.5}$, Q [$m^3 s^{-1}$] is the discharge flowing in the pipe and u [$m^{-1} s^2$] is the dimensional resistance coefficient.

Assuming that each hydrant withdraws the nominal discharge, d [$l s^{-1}$] even when its head is lower than the minimum required (H_{min}), if the discharge is fixed at the upstream end of the network, the number of hydrants simultaneously operating (K_r) is¹:

$$K_r = Q_r / d \quad (49)$$

where Q_r [$l s^{-1}$] is the upstream discharge. Once the available piezometric elevation at the upstream end of the network, Z_0 [m a.s.l.], is established, the set of discharges to be tested, Q_r , and the number of configurations, C , to be investigated for each discharge are selected. From the Eq. 49, the number of hydrants corresponding to each discharge Q_r is calculated. Later, by using the RGM (see chapter 3), the K_r hydrants simultaneously operating are randomly drawn. This procedure is repeated C times for each discharge Q_r .

Based on the analysis of a large number of irrigation systems, the number of configurations to be tested should be higher than the number of hydrants in the network ($C > R$) when $R < 200$ but the number is smaller when R is very large ($R > 600$). The discharges flowing in each section of the network for each discharge Q_r are obtained by aggregating, from downstream to upstream, the discharges delivered by the selected K_r hydrants.

Starting from the upstream piezometric elevation, Z_0 , Eq. 50 is used to calculate the head losses² and the head available at each hydrant in each configuration. Indeed, those hydrants having a head lower than the minimum pre-established (H_{min}) are identified and defined as unsatisfied hydrants. The percentage of unsatisfied hydrants (PUH) out of the total number of open hydrants in the investigated configuration is plotted in a plane (Q , PUH).

Selecting a large number of configurations for a given upstream discharge, the analysis provides a variable number of unsatisfied hydrants, thus a range of PUH for that given discharge. Repeating this procedure for several discharges, a cloud of points is obtained in the plot. An upper and a lower envelope curve will contain all points. The upper envelope represents the maximum percentage of unsatisfied hydrants for the range of discharges under consideration and for all the investigated configurations. The lower envelope represents the minimum PUH for the number of investigated configurations. When the number of tested configurations is large, the PUH can be assigned to different probabilities of occurrence. Envelope curves representing equal probabilities that PUH is exceeded for the discharges being considered can be plotted (Fig. 59).

¹ In the case of different hydrant discharges, the same procedure reported in the previous section is applied. Random drawing will be performed to satisfy the relationship:

$$|Q_{tir} - Q_i| < \epsilon_t$$

where Q_{tir} is the discharge corresponding to K hydrants drawn at random ($l s^{-1}$) and ϵ_t is the accepted tolerance. In general, ϵ_t is assumed as equal to the value of the lowest hydrant discharge.

² Local head losses are neglected in the computations. Usually they are small with respect to the linear head losses and they may be taken into account when the upstream piezometric elevation is analysed.

FIGURE 58
Flow chart of AKLA

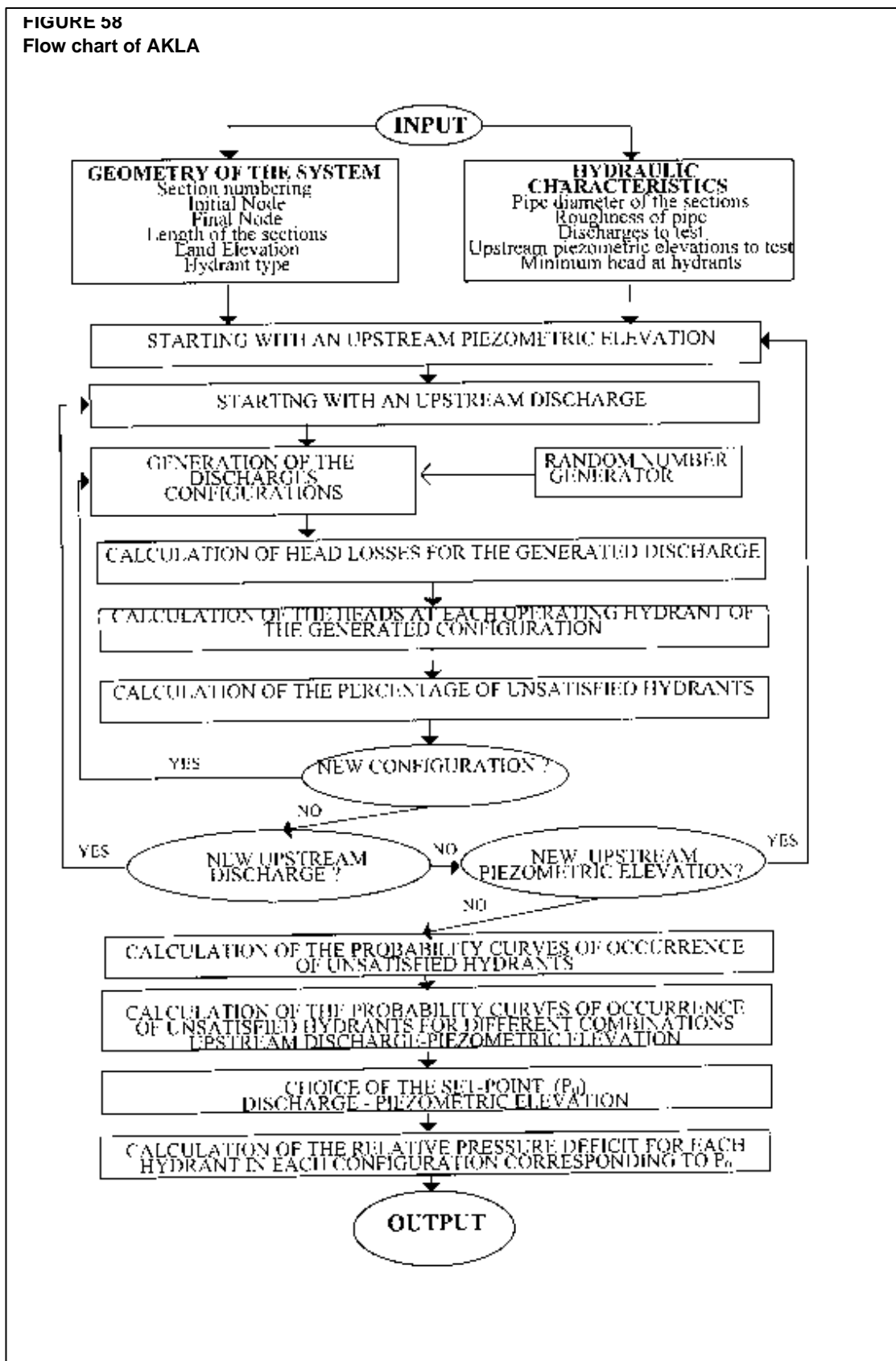

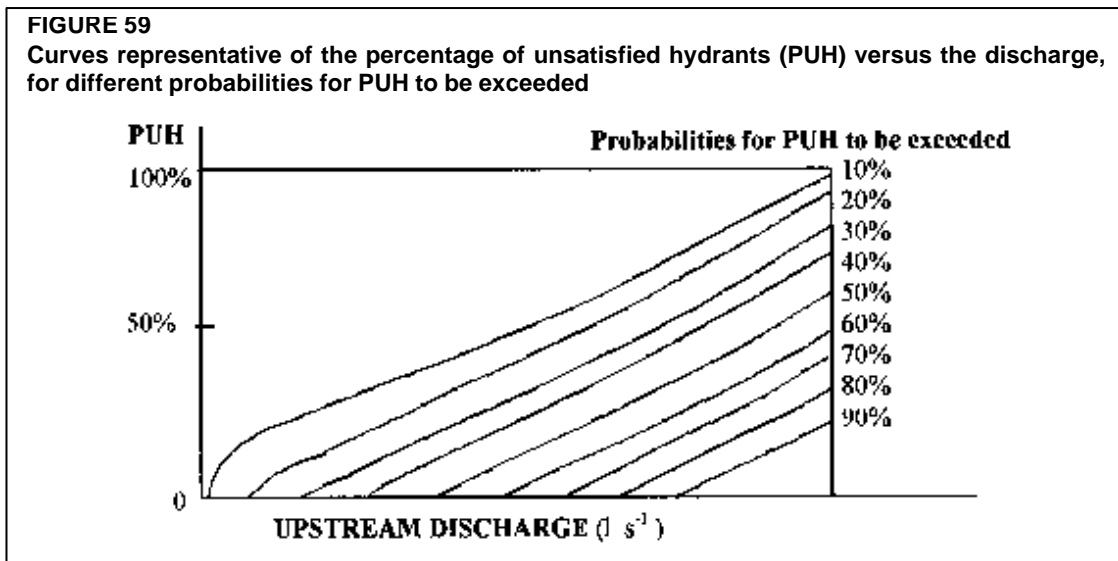

Probability curves can also be plotted for the upstream piezometric elevation (Z_0). Thus, by selecting the 10% of probability of being exceeded curve, a new diagram is obtained giving the percentage of unsatisfied hydrants with the variation of upstream piezometric elevation (Figure 60). From this diagram, through a simple transformation of coordinates, the curves of the PUH (Figure 61) are obtained in the plane (Q, Z).

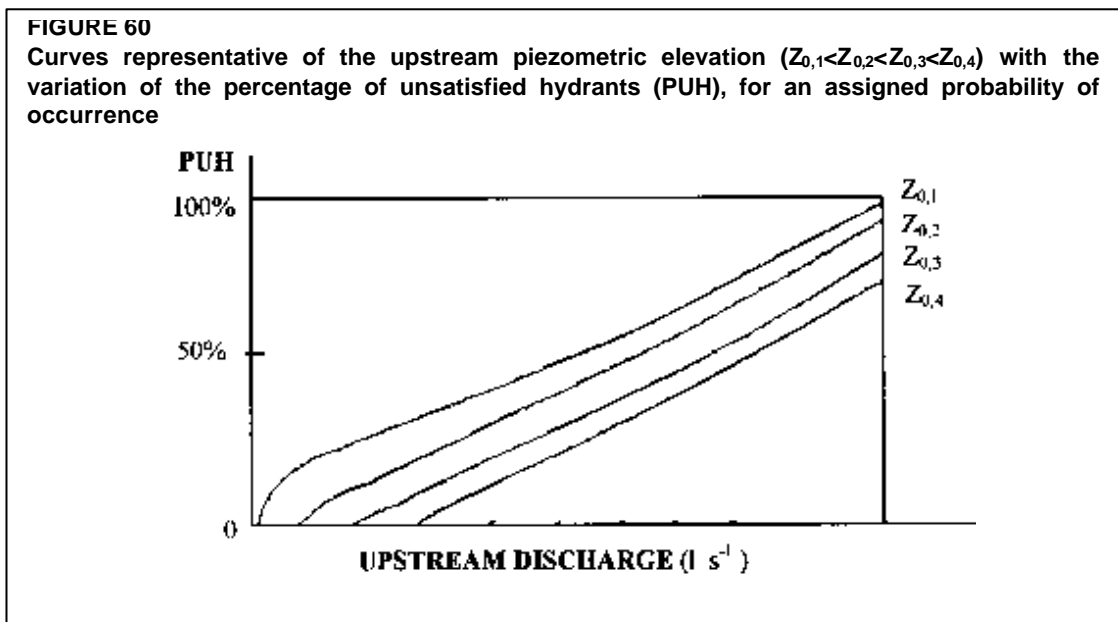

This last representation is interesting because it provides for an immediate and complementary comparison with the indexed characteristic curves model. Indeed, through the analysis of both models, the number of fully satisfied configurations as well as the percentage of unsatisfied hydrants are identified with the variation of the piezometric elevation at the upstream end of the network.

Furthermore, once the analysis is completed, it is also possible to identify, for each configuration, the range of variation of the head at each hydrant. Indeed, the relative pressure

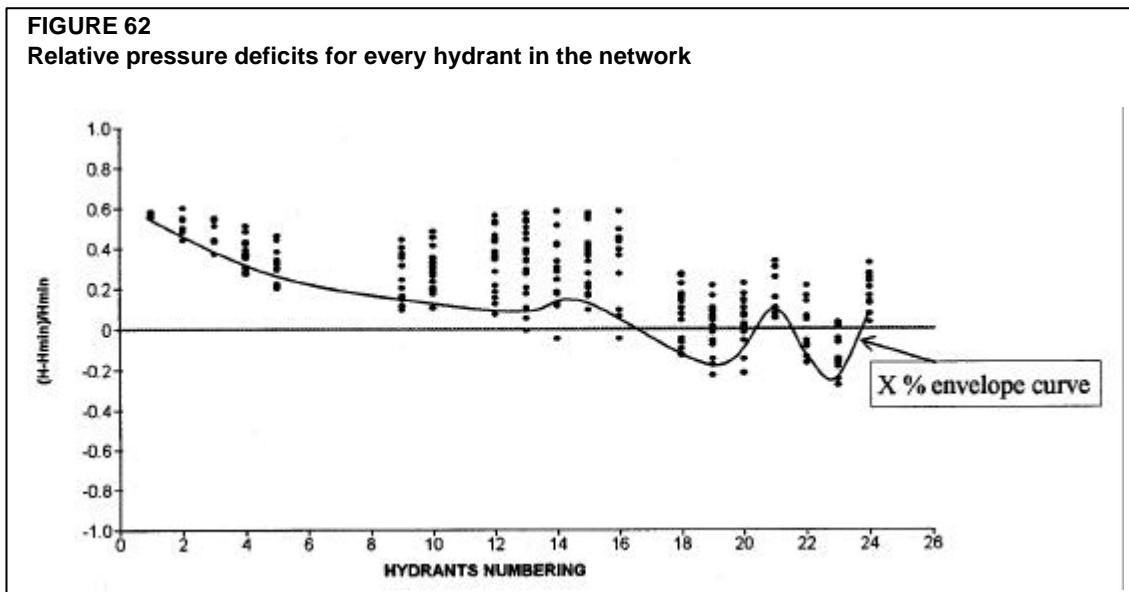
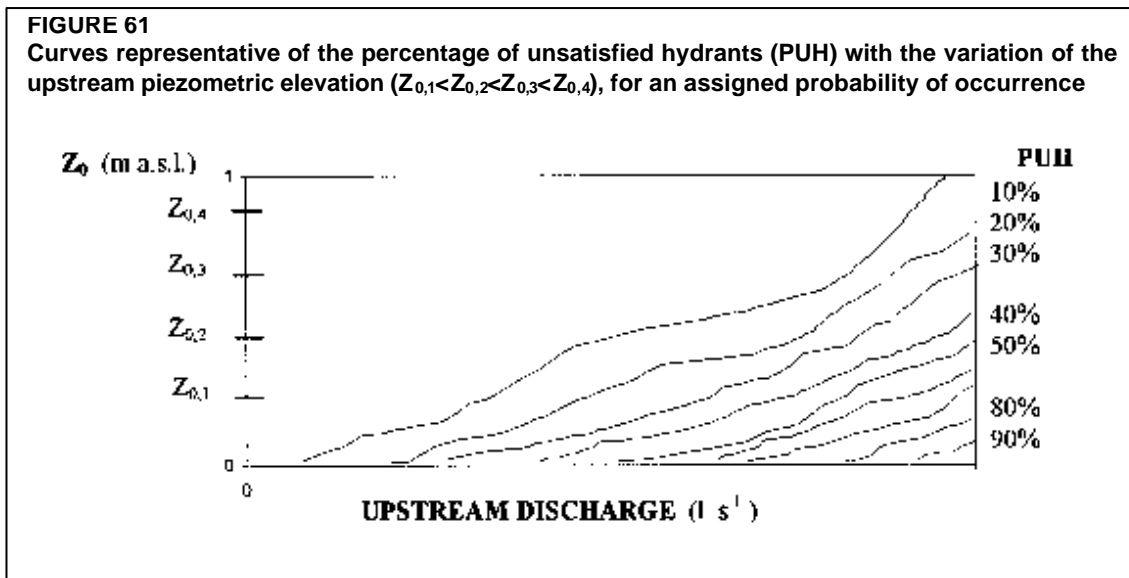

deficit, $\Delta H_{j,r}$ (Eq. 52), may be represented in a plane (Hydrants numbering, ΔH). In this way, the hydrants which are most subject to insufficient pressure head and critical zones of the network are clearly identified (Figure 62). Also, the upper, the lower and the indexed envelope curves (from 10% to 90%) may be represented in the same plane.

Computer software for the computation of the percentage of unsatisfied hydrants and the relative pressure deficits is integrated into the COPAM package (see Figure 63). It is used for the applications presented hereafter.

By clicking on the button program “AKLA” (Figure 63), Figure 64 will appear.

Within the “Options” Tab control, two alternative types of flow regimes are available (Figure 64): the first automatically generates the random flow regimes and the second reads the flow regimes from an external file.

FIGURE 63
Hydrants analysis program: AKLA model

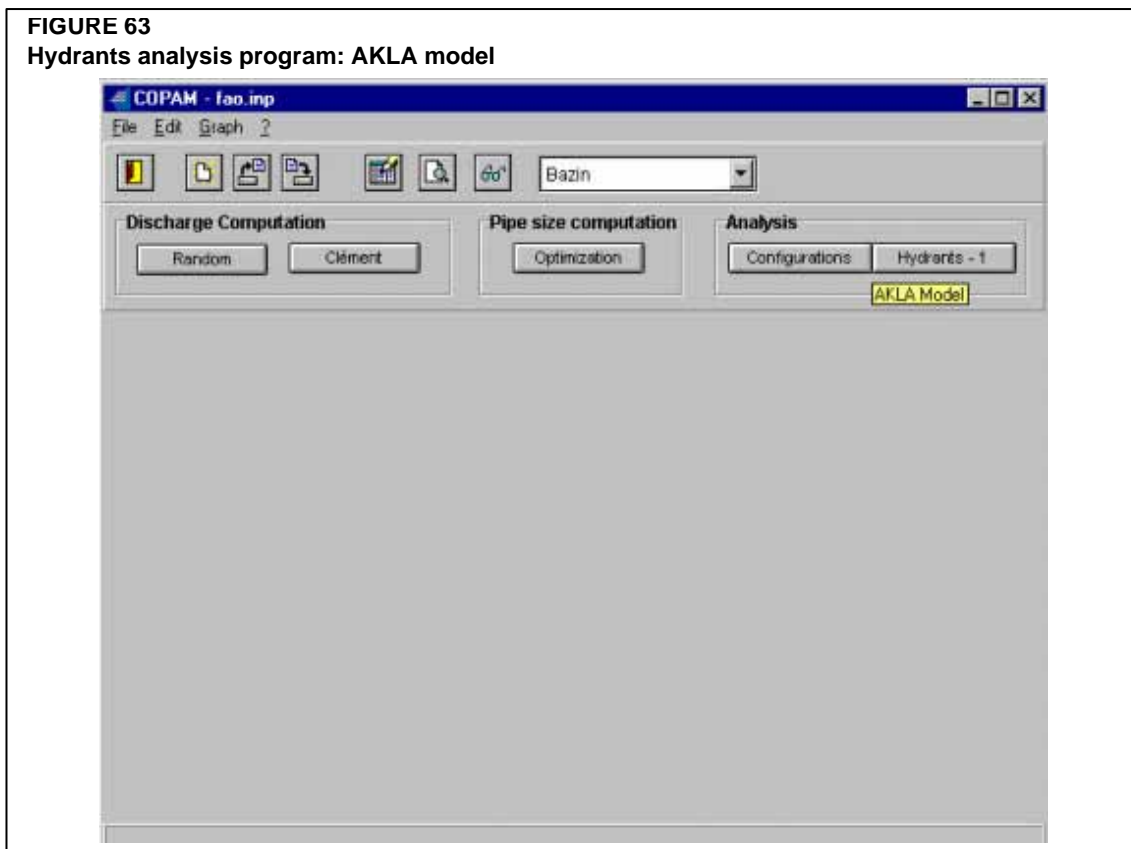

FIGURE 64
Hydrants analysis program: "Options" Tab control, "Several-random generation" flow regime

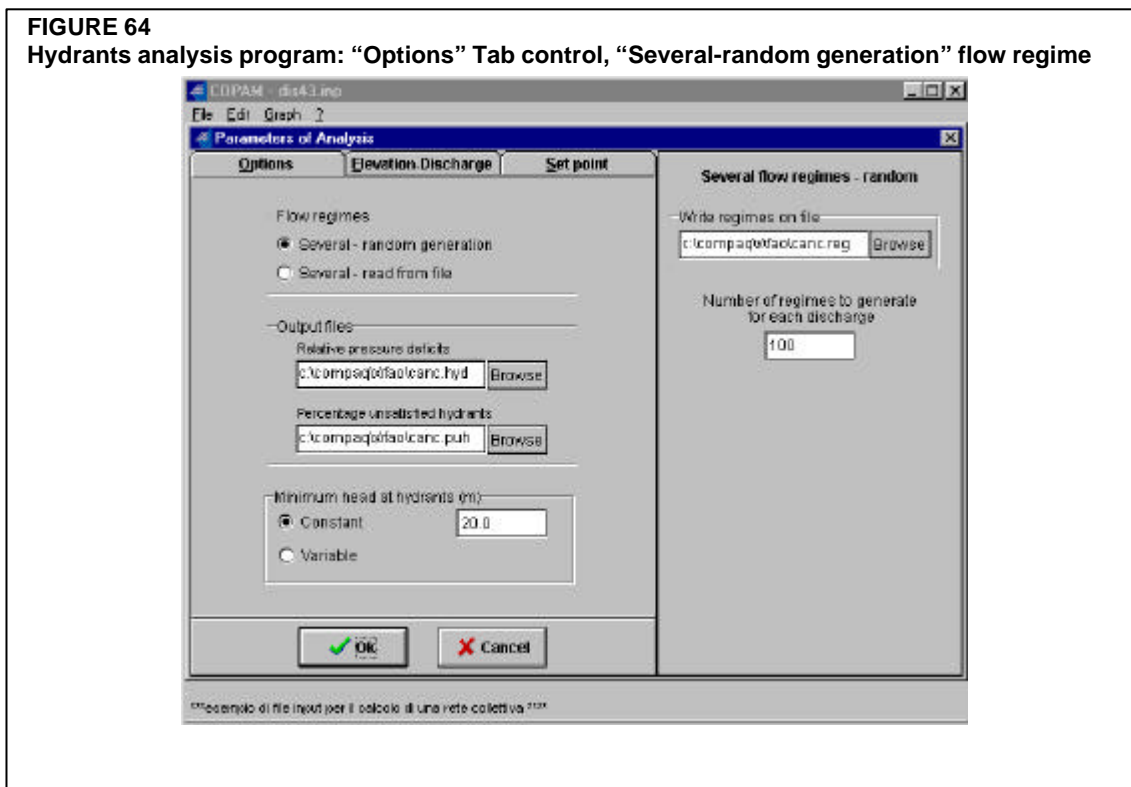
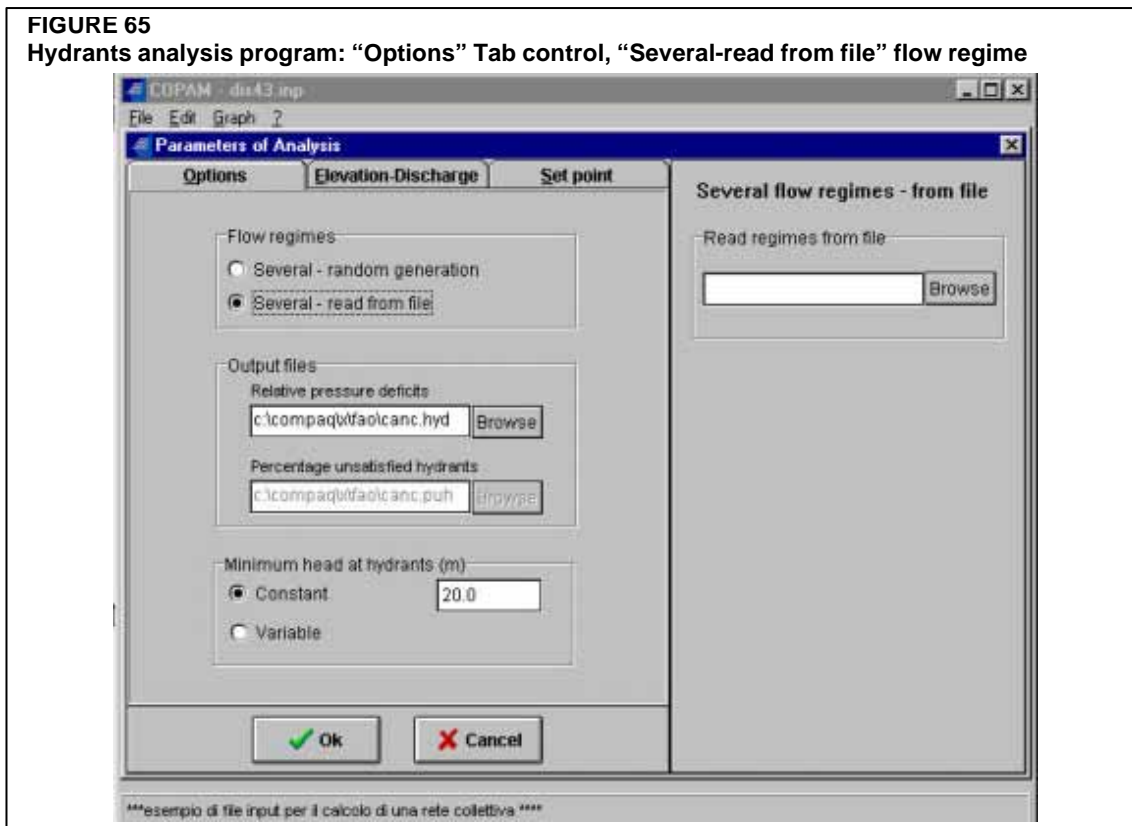

FIGURE 65

Hydrants analysis program: “Options” Tab control, “Several-read from file” flow regime



This second option allows analysis of irrigation systems operating on rotation and/or on arranged demand. In these cases, in fact, the flow regimes are previously generated according to the management rules and stored in an appropriate file to be read by the program (see Figure 65).

The name of the output file for storing information on the hydrants relative pressure deficit (extension “.hyd” is automatically assigned to this file) and on the percentage of unsatisfied hydrants (extension “.puh” is automatically assigned to this file) is written in the appropriate edit boxes, as well as the name of the file in which the random generated flow regimes are stored (Figure 64) (extension “.reg” is automatically assigned to this file).

If the option “Several – random generation” is selected, the number of regimes to generate for each discharge is typed in the appropriate edit box (Figure 64).

If “Several - read from file” is selected, the name of the file in which flow regimes have been previously generated and stored is input in the box “Read regimes from file ...” (Figure 65). In this case the number of flow regimes to be generated is not required because the flow regimes are already stored in the file

The program allows network computations where the minimum pressure head (H_{\min}) required for an appropriate on-farm irrigation is constant or variable. In the first case, the radio button “Constant” is selected in the frame “Minimum head at the hydrants” and the value H_{\min} has to be written in the appropriate box. In the other case, the option “Variable” is selected and the values of the minimum head at each hydrant are typed in the last column of the input file (see Figure 50).

FIGURE 66
Hydrants analysis program: "Set point" Tab control.

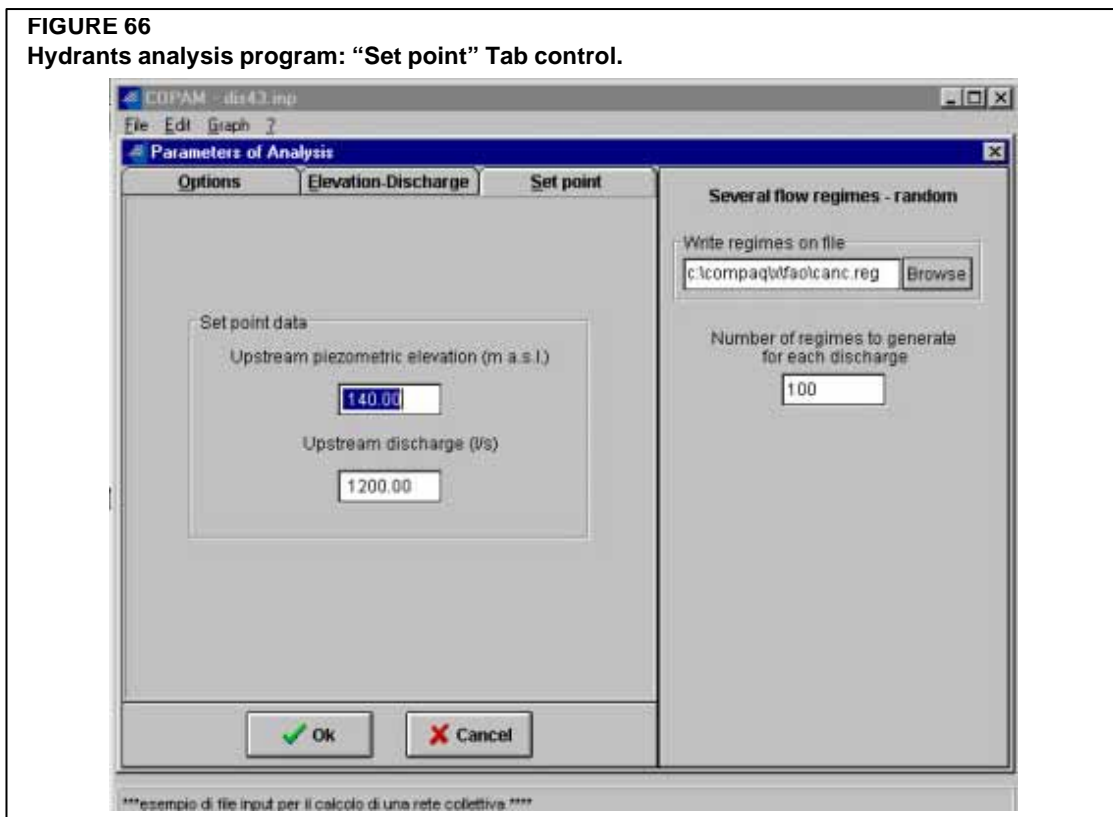

FIGURE 67
Hydrant analysis program: "Elevation-discharge" Tab control.

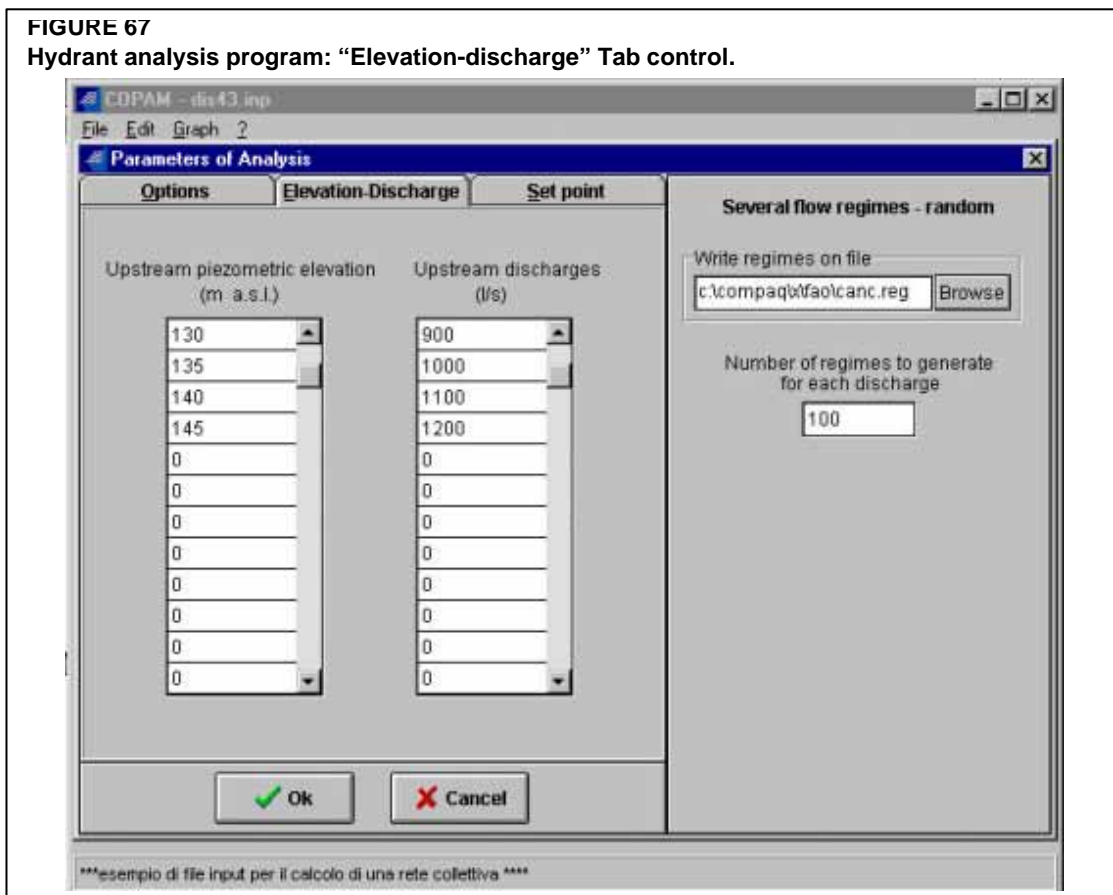
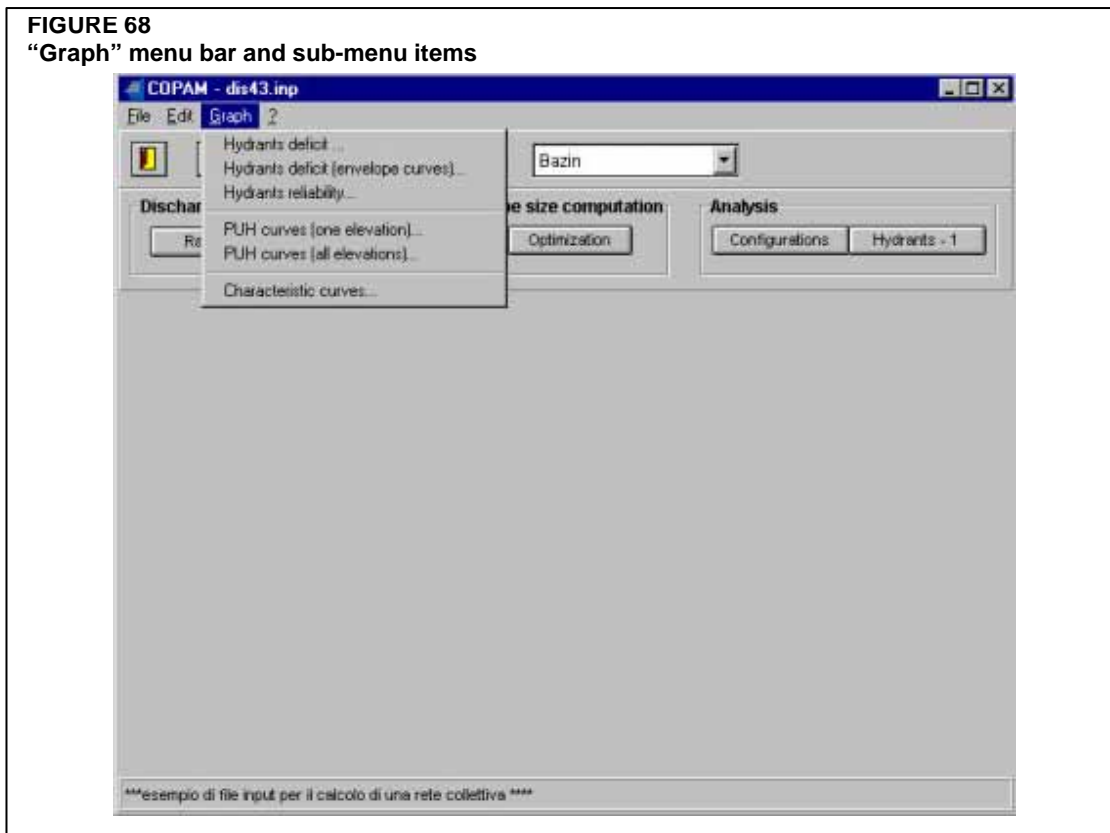

FIGURE 68
“Graph” menu bar and sub-menu items



The piezometric elevation (in m a.s.l.) available at the upstream end of the network, and the design upstream discharge (in $l\ s^{-1}$) are typed in the “set point” tab control (Figure 66). The list of the discharges flowing at the upstream end of the network and the list of the upstream piezometric elevations to be tested are inserted in the appropriate boxes under the “Elevation-Discharge” Tab control (Figure 67). These values allow the computation of the percentage of unsatisfied hydrants when the upstream discharges and piezometric elevations vary.

It is important to include the set point data among these values. In fact, the relative pressure deficits are computed only for the set point values. When the user does not need to investigate the variation of the percentage of unsatisfied hydrants but has interest only in investigating the relative pressure deficits for the set point data, only the set point values are typed in the boxes of the “Elevation-discharge” Tab control.

An application of the AKLA model is reported in the next section. It refers to the same irrigation network analysed with the characteristic curves model in the application 2 of the present chapter. This application better shows the target of the AKLA model and its improvements may be better understood by comparing the results of the two models.

The graphical interface of the COPAM package allows easy printing of the information obtained by the AKLA model. In fact, by clicking on the “Graph” menu bar it is possible to select the available sub-menu items (Figure 68): hydrants deficit, hydrants deficit (envelope curves), PUH curves (one elevation), PUH curves (all elevations). The items “PUH curves (one elevation) ...” and “PUH curves (all elevations) ...” are referred, respectively, to the Figures 59 and 60. The graphical interface allows printing of the hydrants reliability, as explained in the next section.

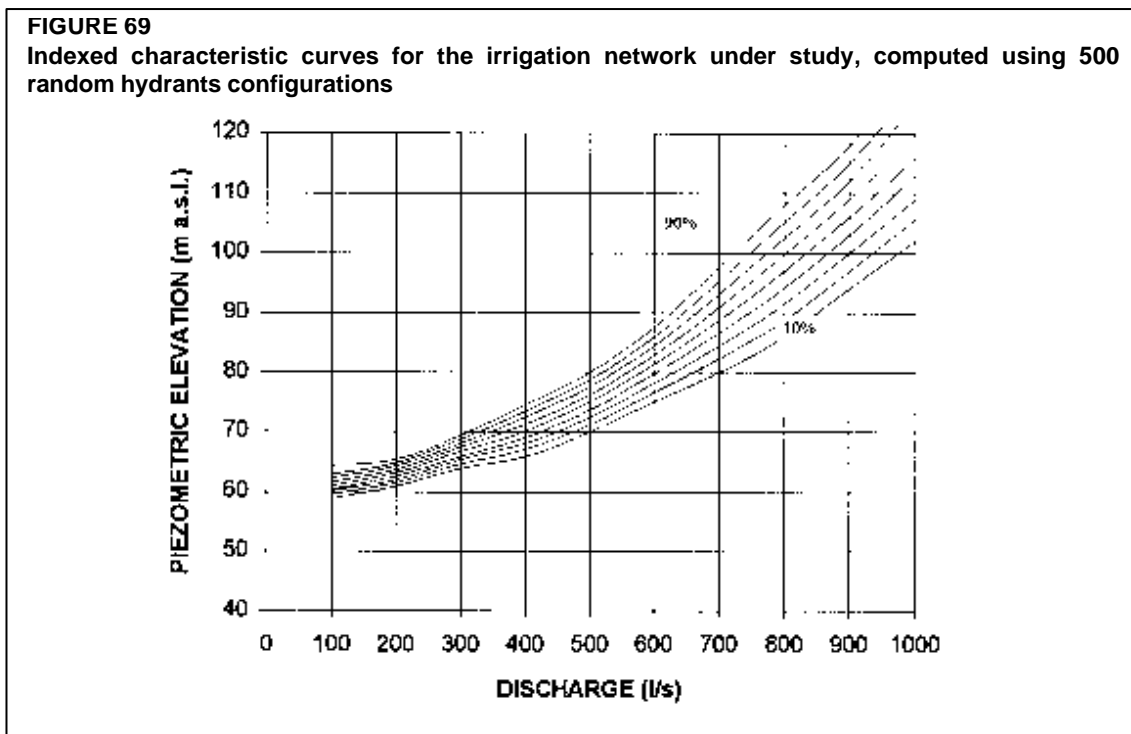

For printing the hydrants deficit and the hydrants reliability, the output file “*.hyd” is selected, while for printing the PUH curves, the output file “*.puh” is selected.

Application 3

The irrigation network analysed hereafter is the same analysed with the characteristic curves model in the application 2 of the present chapter. It serves a total area of 1340 ha and it is equipped with 344 hydrants, out of which 253 of 5 l s^{-1} , 62 of 10 l s^{-1} and 33 of 20 l s^{-1} . It is designed for on-demand operation. The discharges in the network were calculated using the first Clément model, giving a maximum value of 680 l s^{-1} at the upstream end. The available upstream piezometric elevation is 81.8 m a.s.l. The minimum head required at each hydrant (H_{\min}) is 25 m, aiming at the low pressure sprinkler and trickle irrigation. The indexed characteristic curves, calculated by the characteristic curves model, are reported in Figure 69.

From these curves, it is observed that the set-point P_0 (675 l s^{-1} , 81.8 m a.s.l.) falls on the characteristic curve of 25%. It means that only 25% of the investigated configurations are fully satisfied, which is a low value. In order to understand if any design change is required, the analysis using the AKLA model was performed. The probability curves relative to the percentage of unsatisfied hydrants corresponding to a given upstream discharge are presented in Figure 70.

Each curve of Figure 70 represents the probability that the percentage of unsatisfied hydrants (PUH) exceeds the indicated values. These curves have been drawn for the upstream piezometric elevation of 81.80 m a.s.l. (design condition). When 10% probability of occurrence is considered (upper curve in Figure 70), the PUH corresponding to the design discharge (675 l s^{-1}) is close to 25%. Therefore, it is concluded that 75% of configurations which were not satisfied (Figure 69) are those including only a restricted number of hydrants (i.e. probably the 15% placed in less favourable position. This was confirmed by the analysis concerning the hydrants (Figures 73 and 74).

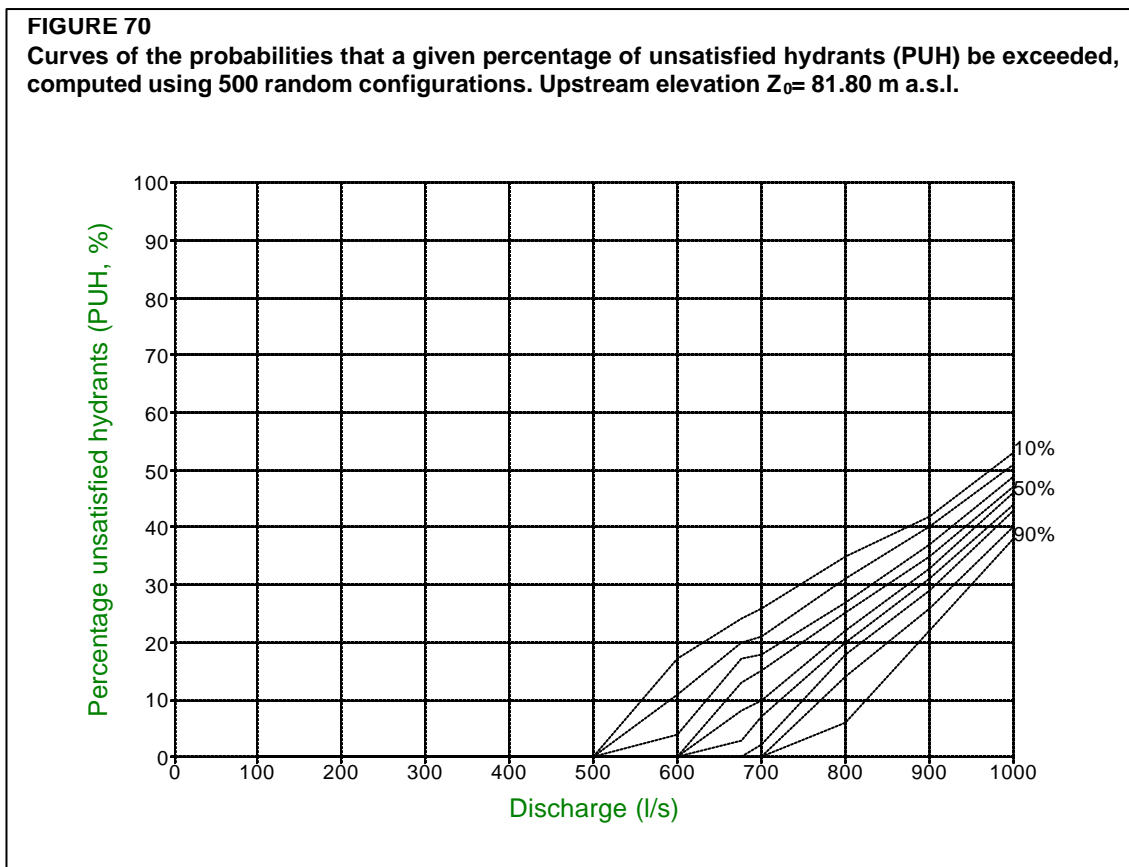

By running the model for different upstream piezometric elevations ranging from 60 to 110 m a.s.l., and by selecting the 10% probability curve (as indicated in Figure 60), Figure 71 was obtained. It shows the variation of the percentage of unsatisfied hydrants (PUH) versus the discharge, for different values of the upstream piezometric elevation and for 10% probability that a higher PUH may occur. This figure gives information on the need, if any, to increase or decrease the upstream piezometric elevation to obtain a lower PUH. At the investigated set-point P_0 (675 l s^{-1} , 81.80 m a.s.l.), this representation confirms a percentage of unsatisfied hydrants equal to about 15%. The whole range of variation of PUH, for the upstream discharge $Q_0=675 \text{ l s}^{-1}$, is comprised between 85% at the piezometric elevation of 60 m a.s.l. and 0% at the piezometric elevation of 100 m a.s.l.

Results in Figure 71 indicate the effect of drop in pressure. If the piezometric elevation falls from $Z_0=81.80$ m a.s.l. to $Z=75$ m a.s.l., the PUH for the design discharge $Q_0=675 \text{ l s}^{-1}$ falls to 33%. When a lower value $Z=70$ m a.s.l. is considered the PUH drops to 50%.

Comparing the characteristic curves in Figures 69 and 71, it is observed that respective results are different. This disagreement between the two models is explained because a part of the project area is located in a zone where land elevation is higher. Indeed, by using the indexed characteristic curves model, anytime one hydrant located in that zone is drawn up, the whole configuration is considered unsatisfied. Consequently, a low percentage of configurations satisfied does result. On the contrary, when using the AKLA model, because only the unsatisfied hydrants, rather than the configurations, are considered, it can be observed that the percentage of unsatisfied hydrants is low.

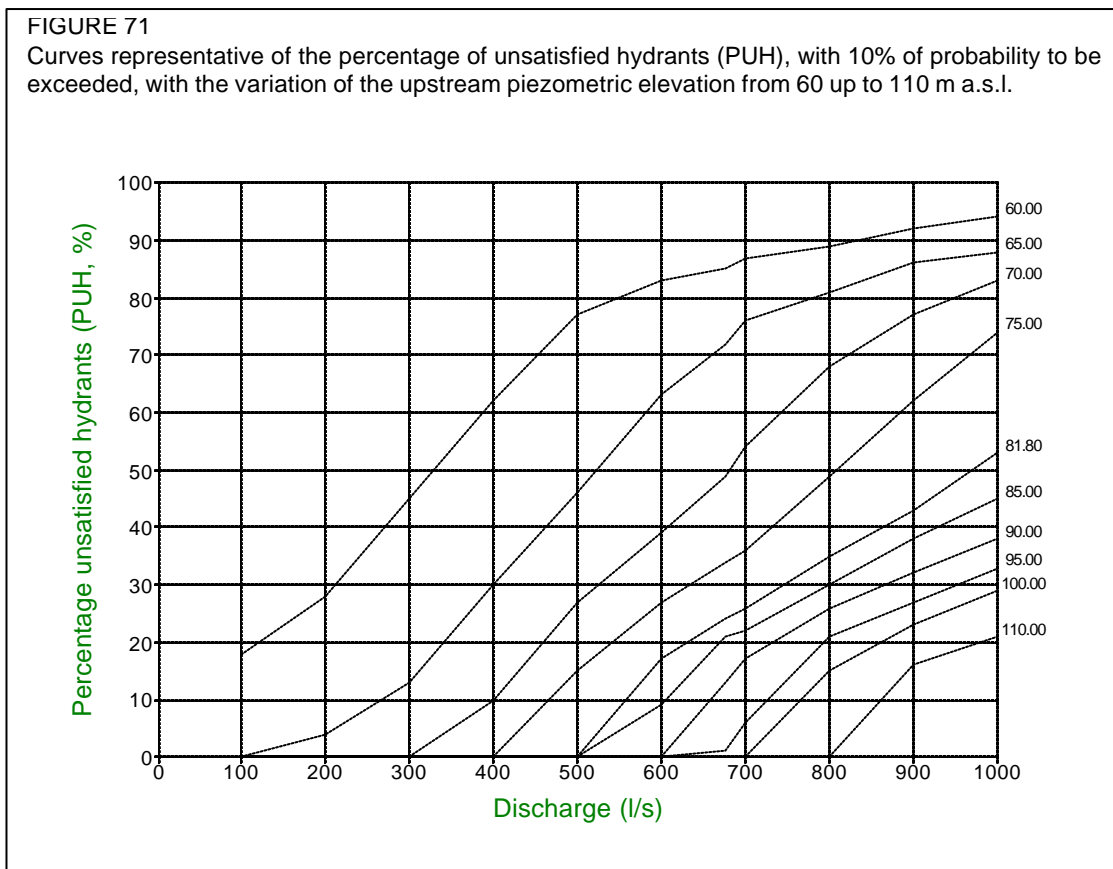

Figure 72 helps to identify the hydrants that are more subject to insufficient pressure and to evaluate the variation range of such dissatisfaction. The corresponding curve obtained when the 10% probability of less satisfactory results are excluded is presented in Figure 73. Both Figures concern the design discharge $Q_0=675 \text{ l s}^{-1}$ and the upstream piezometric elevation $Z_0=81.80 \text{ m a.s.l.}$

From the analysis of these figures it is observed that, for the whole set of investigated configurations, the zones potentially subject to failure correspond to the hydrants numbered from 90 to 140 and from 165 to 240. By analysing Figure 73 it is concluded that the most critical zones of the network are those relative to the hydrants numbered from 165 to 240. The relative pressure deficit close to $\Delta H = -0.5$ indicates that rehabilitation techniques are required for the hydrants in less favourable elevations. Clearly, models for the analysis of pressurized irrigation networks are extremely useful to determine the hydraulic performance of the systems, particularly those operating on-demand.

It was observed that the indexed characteristic curves model does not provide enough information on the local hydraulic behaviour of a network, despite the usefulness of information supplied both to designers and managers. In fact, the analysis of the indexed characteristic curves can help to support decisions concerning:

- lifting plant design, which can adjust the set-point of the pumps to the characteristic curves of the network and obtain important energy savings;

FIGURE 72

Relative pressure deficits at each hydrant when 500 discharge configurations were generated. Discharge $Q_0=675 \text{ l s}^{-1}$ and upstream piezometric elevation $Z_0=81.80 \text{ m a.s.l.}$

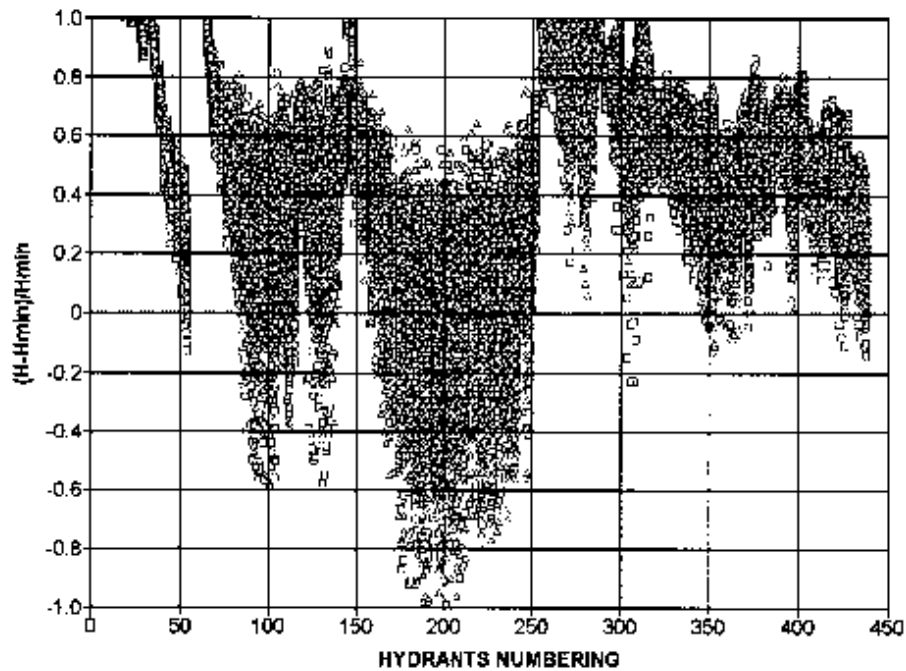
**FIGURE 73**

Variation of the relative pressure deficit at each hydrant in each discharge configuration. Discharge $Q_0=675 \text{ l s}^{-1}$ and upstream piezometric elevation $Z_0=81.80 \text{ m a.s.l.}$ Envelope curve by eliminating 10% of the most unfavourable points.

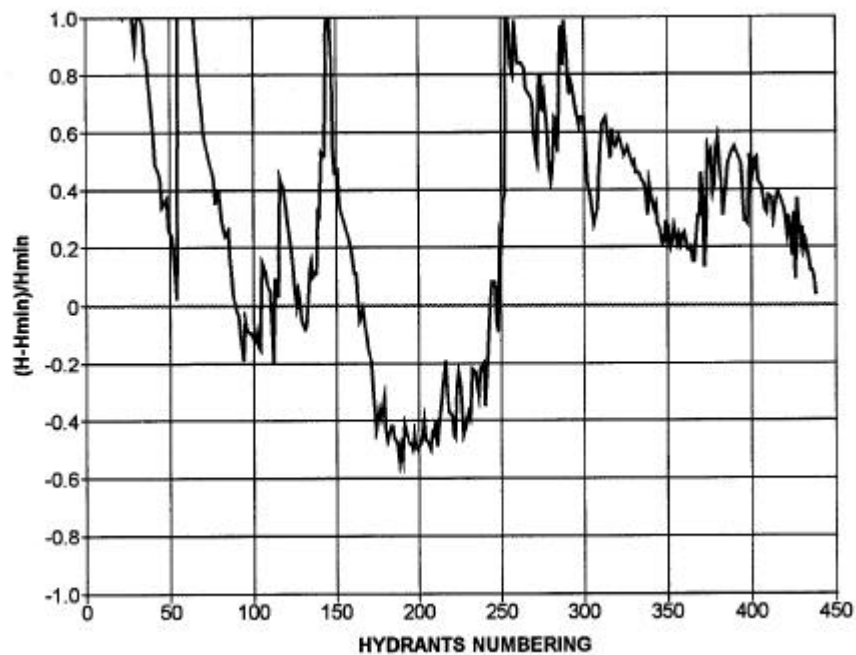

- increasing pipe diameters in the network for reducing head losses to increase the number of satisfied configurations. In fact, introducing these improvements will reduce the slope of the indexed characteristic curves and increase the number of satisfied configurations;
- increasing the upstream piezometric elevation (at the pumping station) in order to satisfy a greater number of configurations.

The AKLA model gives more precise information by determining not only the percentage of unsatisfied hydrants, but also where these hydrants are located and the magnitude of the pressure deficit. Consequently, it is possible to identify the areas with special problems for which specific measures and special solutions may be adopted. These solutions can be applied both at the collective and the individual levels.

In order to solve problems of insufficient pressure at the hydrants located in critical areas, several solutions are possible:

- reinforce pipe sizes of those sections which are producing a great pressure loss upstream of the critical area;
- install additional in-line lifting units;
- impose limitations to the farmers' freedom to withdraw water in that area. It may be possible by placing, upstream, special devices able to stop irrigation during the peak demand hours;
- modify management rules;
- increase the head of the pumping station.

At the individual level, on the contrary, it is possible to:

- install additional lifting units (booster pumps) downstream of the critical hydrants;
- optimize the design of the on-farm system to reduce head losses and improve operation;
- suggest that the farmers in critical areas avoid irrigating during peak hours;
- suggest that the farmers choose low pressure irrigation methods.

Reliability indicator

Monitoring of existing irrigation systems is often suggested to obtain information on the behaviour of the systems and to formulate models that simulate operational scenarios and identify conditions of poor performance. The ability of an irrigation system to operate satisfactorily within a wide range of irrigation demands is an important system characteristic (Hashimoto, 1980; Hashimoto *et al.*, 1982). In many studies, the operational status of a water resource system can be described as either satisfactory or unsatisfactory. The occurrence of unsatisfactory conditions is defined as failure. A failure in a pressurized irrigation system corresponds to a drop in pressure head (and/or discharge) at the hydrant below the minimum required for an appropriate on-farm irrigation.

In this section the reliability performance indicator for identifying an irrigation system failure, especially during peak periods, is described. It can be utilized for improving both design and analysis of irrigation systems. The system reliability describes how often the system fails (Hashimoto, 1980; Hashimoto *et al.*, 1982). The mathematical definition of this criterion is formulated assuming that the performance of an irrigation system is described by a stationary stochastic process. It means that the probability distributions describing the time series (in this case the time series of pressure heads and discharges at the hydrant being considered) do not change with time. This hypothesis is only an approximation but, particularly during the peak periods, it is a reasonable assumption.

Let X_t be the random variable denoting the state of the system at time t (where t assumes values $1, 2, \dots, n_t$). In general, the possible values of X_t are shared into two sets: S , the set of all satisfactory outputs and F , the set of all unsatisfactory outputs (failure). At each instant t the system may fall in one of the above sets. The reliability of a system is described by the probability α that the system is in a satisfactory state:

$$\alpha = \text{Prob} [X_t \in S] \quad (53)$$

In the case of pressurized irrigation systems, the reliability of each hydrant was defined and computed from the results obtained by the AKLA model. In fact, from the definition of reliability given in the Equation 53, the following relationship is obtained:

$$\alpha_j = \frac{\sum_{r=1}^C I_{h_{j,r}} I_{p_{j,r}}}{\sum_{r=1}^C I_{h_{j,r}}} \quad (54)$$

where:

α_j = reliability of the hydrant j ,

$I_{h_{j,r}} = 1$, if the hydrant, j , is open in the configuration r ,

$I_{h_{j,r}} = 0$, if the hydrant, j , is closed in the configuration r ,

$I_{p_{j,r}} = 1$, if the pressure head at the hydrant, j , open in the configuration r , is higher than the minimum pressure head,

$I_{p_{j,r}} = 0$, if the pressure head at the hydrant, j , open in the configuration r , is lower than the minimum pressure head,

C = total number of the generated configurations.

For each discharge configuration the analysis performed with the model AKLA gives the available head [m] at each operating hydrant. Therefore, the indexes $I_{h_{j,r}}$ and $I_{p_{j,r}}$ are easily calculated and the relationship 54 is solved.

The reliability computation is included in the AKLA program and integrated in the COPAM package. A graphical output of this performance indicator is obtained by clicking on the item "Graph/Hydrants Reliability ..." in Figure 68.

Application 4

In this section, both the reliability and the relative pressure deficits indicators for an actual Italian irrigation system are computed. The layout of the network is in Box 2 of Chapter 3. The input file data are reported in the Annex 3. All the hydrants of the network have nominal discharge of 10 l s^{-1} . The minimum pressure head for each hydrant is $H_{\min} = 20 \text{ m}$.

Two sets of 200 random discharge configurations, corresponding respectively to 5 and 6 hydrants simultaneously operating, were previously generated using the Random Generation Model. Each discharge configuration corresponds to 50 l s^{-1} in the first set (i.e. design condition), and to 60 l s^{-1} in the second set.

From the Equation 54, the reliability of each hydrant is computed and reported in the Figure 74. Reliability between 0.3 and 0 is observed for the hydrants 18, 19, 20, 22 and 23. Reliability is between 0.9 and 1 for the hydrants 9, 10, 12, 13, and 24 while values between 0.9 and 0.8 are observed for the hydrants 14, 15 and 16.

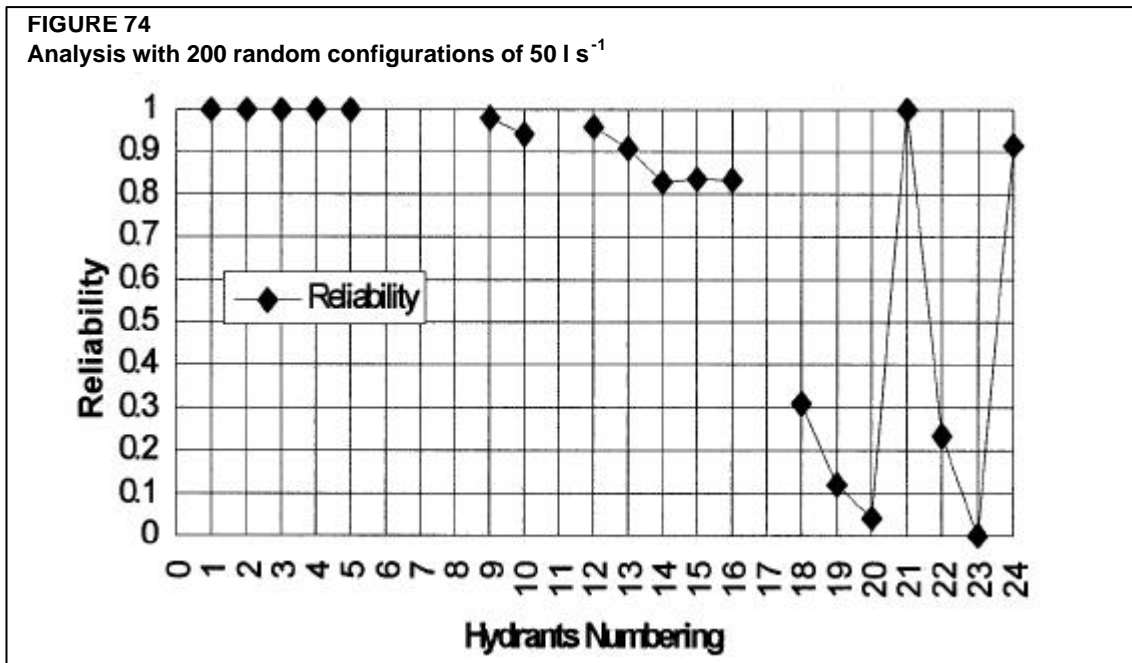

When the analysis is performed with 200 random discharge configurations of 60 l s^{-1} the reliability at each hydrant is reported (Figure 75). In this case, reliability values between 0.3 and 0 are observed for the hydrants 18, 19, 20, 21, 22, 23 and 24, and between 0.8 and 0.4 are observed for the hydrants 9, 10, 12, 13, 14, 15 and 16. Reliability equals one only for the hydrants 1, 2, 3, 4 and 5.

The relative pressure deficits and the 90% envelope curve are reported in Figures 76 and 77. The analyses were performed respectively with the sets S_1 (200 RGM configurations of 50 l s^{-1}) and S_2 (200 RGM configurations of 60 l s^{-1}) of flow regimes.

Important pressure deficits for almost all the hydrants are observed especially when discharges higher than 50 l s^{-1} flow in the network. The performance is low and no assurance of satisfaction exists, especially when scenarios different from the design conditions occur in the system.

These analyses lead to a precise identification of unsatisfied hydrants. Therefore, the rehabilitation and/or modernization processes may be selected for existing irrigation systems.

These processes may concern either physical or management rehabilitation. In the first case, for example, the most critical pipes may be identified and changed through the optimization models presented in section 4. In the second case, the management rules may be modified by changing the on-demand delivery schedule into arranged demand by selecting a more appropriate turn to apply.

One can easily select criteria for modernization. For example, when the manager decides to set constraints for the critical hydrants, special devices (see the next section: "Management issues") activated by a pre-programmed electronic card, could be installed in order to match water resource supply and demand.

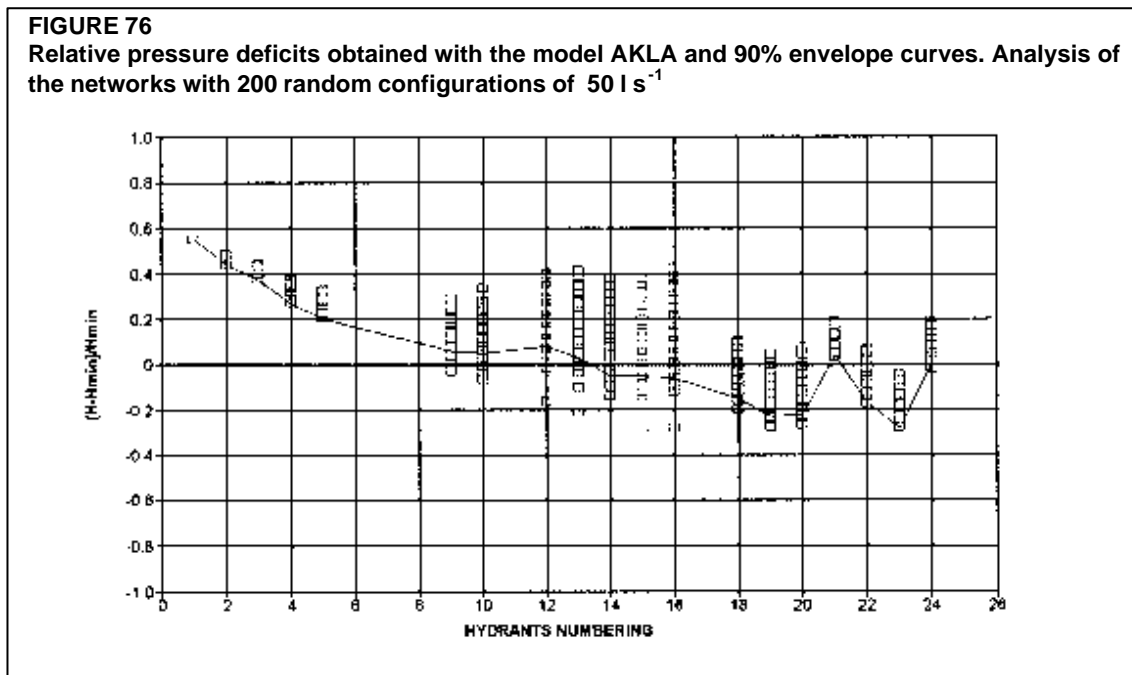
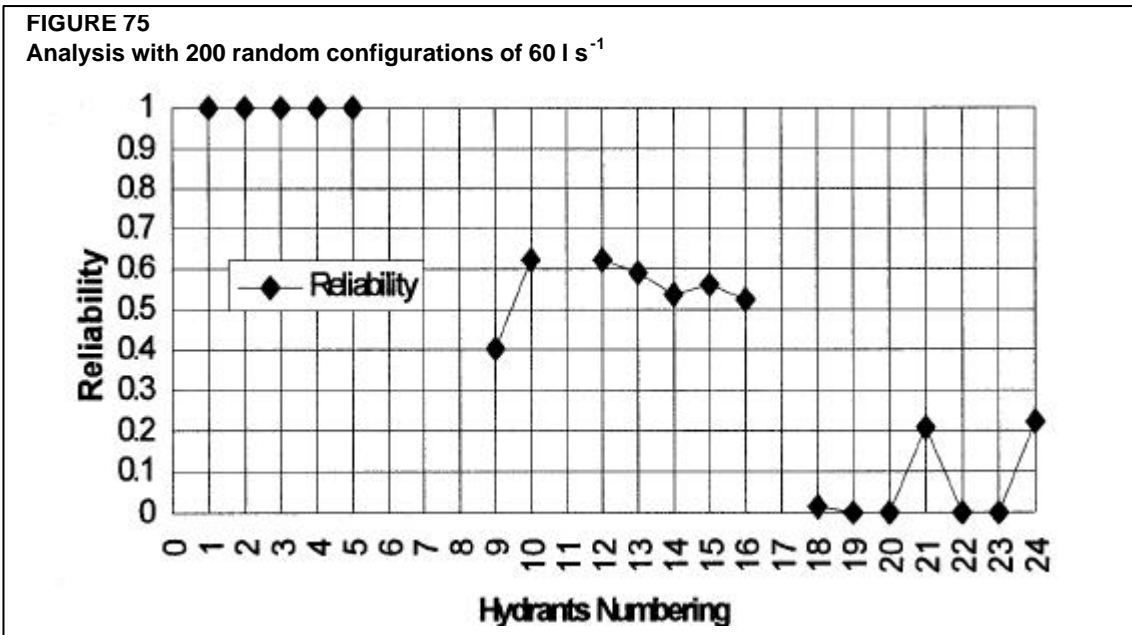

The models for network analysis may be also used in the design process. In fact, an irrigation system that was designed with a classical approach can later be analysed with the above described models. If the performance of the system is not suitable, one can make improvements. The most suitable solution for improving the irrigation system is to agree with the managers about increasing the most critical pipe diameters, setting constraints for the critical hydrants, planning adequate tariff rules, planning different types of delivery schedules, planning special devices, and so on.

FIGURE 77
Relative pressure deficits obtained with the model AKLA and 90% envelope curves. Analysis of the networks with 200 random configurations of 60 l s^{-1} .

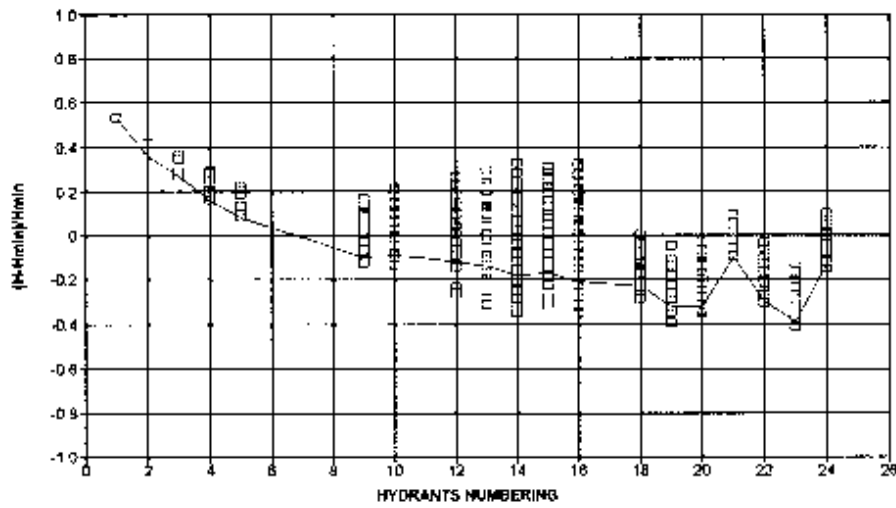

Chapter 6

Management issues

SOME GENERAL CONDITIONS FOR A SATISFACTORY OPERATION OF ON-DEMAND SYSTEMS

A large number of on-demand irrigation networks have been developed over the past thirty years. While the majority of them have been found to perform to the satisfaction of farmers and development authorities, there have been a number of cases where the design was below expectations.

A closer analysis of the cases with poor performance records shows that many of the criticisms leveled against on-demand systems are attributable to shortcomings in:

- *Unsuitable size of family holdings and*
- *Low levels of irrigation and farm management knowledge*
- *Non volumetric pricing of water*
- *Incorrect estimation of the design parameters*
- *High energy costs*
- *Lack of qualified staff for the operation and maintenance of the system*

Experience shows that for on-demand systems to give satisfactory results, some basic criteria are needed (FAO, 1990):

Suitable size of family holdings

On-demand systems are probably less suited to certain social environments such as large farms with abundant hired labour or very small holdings run by unskilled farmers. Due attention must therefore be paid to the application of on-demand systems where the size of the farm enterprise is predominantly coherent with the socio-economic context of the project.

In the case of the very large farms with abundant labour, the flexibility afforded by an on-demand system appears to be superfluous since detailed planning of irrigation tasks entrusted to personnel exclusively engaged in this work is possible. Distribution on a rotation basis seems better suited to such a situation, provided that the stream size is sufficient.

On-demand systems are often not well suited to the needs of very small holdings if the farmers have a low level of skill. Here the existence of a rotation provides a strict framework which assures a proper understanding of the quantity of water to be used, as well as the proper frequency of application. Furthermore the extension of the pipe network to every farm becomes expensive and cost repercussions are inevitably high.

Medium to high levels of irrigation and farm management knowledge

On-demand systems were originally placed at the disposal of family holdings on which diversified crops were grown and where farming experience was generally high. These farmers had a high standard of farm management and were eager to make the best possible use of this

new tool which allowed for a more flexible integration of irrigation practices with other farming activities and the results were positive. However, other experiences have shown that, when such technology was made available to farmers with little or no knowledge of irrigation and reduced farming experience, long adaptations period with strong training efforts were required until the new technology was used in a satisfactory manner.

Volumetric pricing

Irrigation water must be priced on a volumetric basis if on-demand systems are to operate economically. If water meters are not installed, the farm hydrants will remain open for durations greater than designed and the system will not operate satisfactorily. Furthermore, a high recovery of the water charges is necessary to guarantee a recurrent flow of funds for the operation and maintenance of the system

Correct estimation of the design parameters

When the flows in on-demand irrigation networks are computed through the probabilistic approach proposed by Clément, a performance analysis of the system is strongly recommended during the design stage. Furthermore, three parameters need careful attention: the degree of freedom, e_h , the use coefficient, r , and the operation quality, $U(P_q)$.

The degree of freedom (or elasticity of the hydrants) defines the freedom afforded to farmers to organize their irrigation. The degree of freedom depends on criteria such as size and dispersion of plots, availability of labor, type of on-farm equipment, frequency of irrigation. Hydrants with capacities of one and a half to twice the value of the duty correspond to the lowest feasible degree of freedom. With smaller values, the probability of a hydrant being open becomes too great for the demand model to apply. Conversely, hydrant capacities should not exceed six to eight times the value of the duty. This corresponds to a high degree of freedom.

The use coefficient, r , was already defined and analysed in chapter 3. The values selected for the parameter r normally lie between 16/24 ($r=0.67$) and 22/24 ($r=0.93$). The performance analysis of existing systems is the most reliable approach for selecting the coefficient r best suited to a given irrigation network (see Annex 1).

The parameter $U(P_q)$ defines the "operation quality" of the network; it normally has values ranging from 0.99 to 0.95. A significant reduction of this parameter beyond these values can lead to the occurrence of unacceptable failures to satisfy the demand in certain parts of the network (Galand *et al.*, 1975).

Reduced energy costs

Many on demand systems were designed at the time that energy costs were considerably lower than nowadays and, therefore, the pipe diameters were reduced as much as possible and compensated with high pressure (at that time cheaper to generate). Such systems have difficulties to operate under principles of financial autonomy and often the public sector has to sustain them with subsidies.

A related problem is that many of the pumping stations that were designed some 20 years ago are integrated by several identical motor pumps that pump the water to a reservoir of fixed

height. The result of this configuration is the lack of adaptation of the pumping station (and related reservoir) to a variable piezometric demand that leads to wastage of energy.

The tendency at present is to reduce the pressure to values compatible with the need at the farm level and to optimize the pipe diameter accordingly. For this purpose the use of the tools included in the COPAM package may facilitate the task of adapting old networks to the new conditions.

Qualified staff for the operation and maintenance of the system

The daily operation of on-demand systems is relatively simple and can be mastered by well trained staff in relatively short time. However a deeper understanding of why the network is not functioning satisfactorily requires a good knowledge of some technical concepts that have a certain degree of complexity. A well qualified staff is required and that, in certain environments, may not be easy to obtain. The operation of and maintenance of the pumping stations with its related equipment also requires well qualified staff and a good system of preventive maintenance .

THE ON-DEMAND OPERATION DURING SCARCITY PERIODS

The ever-increasing demand of water for irrigation, together with the growing difficulties and costs for developing new resources, make it necessary to carry out field surveys aiming at a better management of irrigation systems as well as to evaluate specific operation and management decisions. When there are difficulties in matching supply and demand during peak periods managers of irrigation projects can change the delivery schedules from on demand to restricted frequency demand by applying different types of rotations among sectors within an irrigation district.

Changes in delivery schedules, however, modify the farmers' behaviour in relation to the withdrawal of water. Often, the rotation among sectors induces all the farmers to irrigate simultaneously when their sector is in charge. In this way, the demand may exceed the upper limit of the discharge allowed in the network, causing an increasing of head losses and, consequently, a reduction in the available pressure at each farm hydrant. Under these circumstances, the on-farm distribution uniformity and application efficiency and, in turn, the global performance of the whole system, is reduced. It is important to evaluate the changes in delivery schedules, particularly concerning the modifications induced in the daily irrigation demands.

A very common cause inducing managers to modify the delivery schedule is the change of the cropping pattern with respect to the design hypothesis. In fact, when more water demanding crops are introduced in the system, the irrigation demand increases and supply is no longer sufficient to match demand. Under this circumstance, a restriction of deliveries is required. Usually, this consists of a rotation among the irrigation sectors of this district, closing the water supply, alternatively, to 50% of the sectors while maintaining free access to the water to the other 50%. This delivery schedule is called "restricted frequency demand", (Clemmens, 1987).

A survey and analysis were performed by Lamaddalena *et al.* (1996) on an Italian irrigation district. The conclusion was that, when a restricted frequency demand is imposed, the daily withdrawal exhibits abnormal behaviour of farmers in the use of water. On the contrary, this behaviour seems to be more regular during the periods when the operation of the district is on-demand.

In Figure 78, the demand hydrographs recorded at the upstream end of a typical network are reported. From these graphs, it is observed that during the on-demand operation farmers tend to irrigate when they need and according to their habit. On the contrary, when restricted frequency demand is applied, all farmers tend to irrigate simultaneously, during daytime and nighttime, by using the maximum discharge permitted by the network. This behaviour often leads farmers to over irrigate their fields because of uncertainty in water availability. Thus, operation under restricted demand does not necessarily induce water saving but rather an increase in water demand. To solve this problem, rather than maintaining the practice of changing delivery schedule, it is appropriate to develop new operation and management rules.

FIGURE 78
Typical demand hydrographs at the upstream end of an irrigation sector: a) on-demand operation; b) arranged demand operation

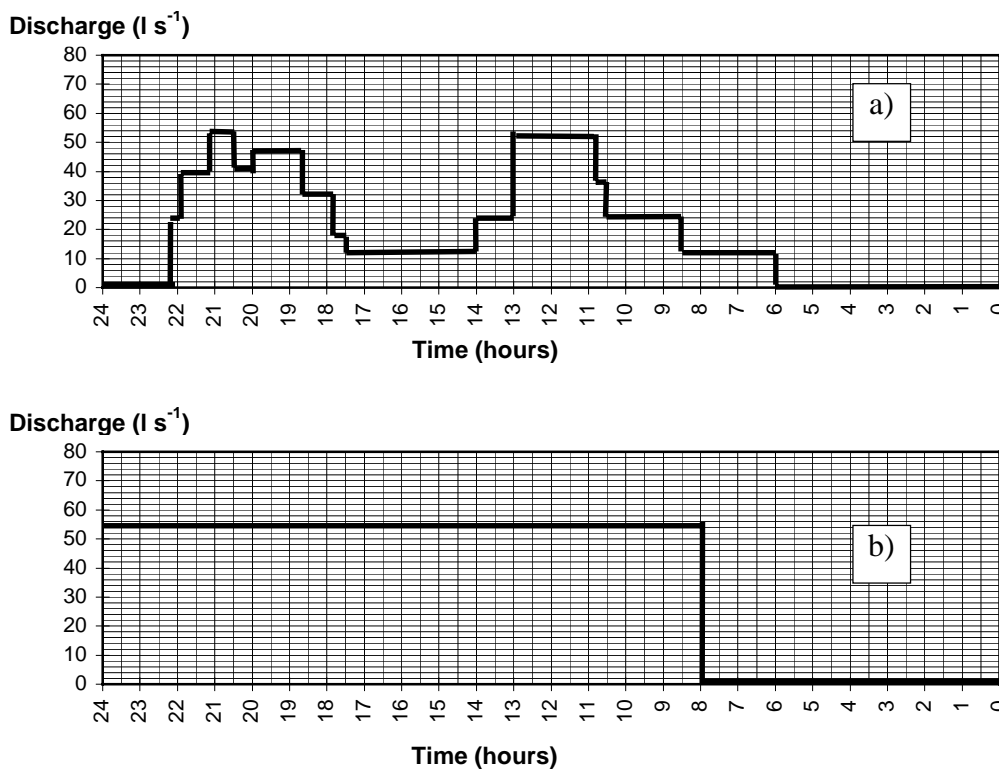

Shortages of the existing irrigation systems are satisfactorily, or at least acceptably, solved by inducing single farmers to modify the flow hydrographs, according to the global capacity of the irrigation system. This approach is expected to be better than the drastic 50% rotational-reduction between sectors.

In view of this, improving distribution and reducing water consumption by each farmer from the installation of new delivery equipment to avoid wastes or useless concentrated withdrawals without penalizing the on-demand operation is beneficial. In fact, these devices, opportunely programmed to limit the delivery volume and/or to limit withdrawals during the daily peak periods, may stimulate farmers to modify the flow hydrographs in such a way to be compatible with the system capacity.

Trials were made on some irrigation systems in Italy to check the reaction of farmers to such limitations. They responded very well and accept such shortage much more willingly than the drastic rotation among sectors. This approach is still under study for identifying exactly which hydrants need to be controlled. Also, the possibility of reducing the night-time and increasing the day-time tariffs is under consideration.

The extension service is vitally important for the success of introducing new technologies (Tollefson and Wahab, 1995). In fact, the extension service is responsible for simplifying research information and transfer it to farmers in an easy and understandable way. The extension service should also provide a feed-back mechanism to researchers on farmers' problems so that a two-way information exchange approach is maintained. Seminars between extension researchers, irrigation agencies industry representatives and farmers, together with cooperative research activities are needed for improving the two-way approach.

The extension service should carried out activities aimed at improving the use of the water resource through the simple and systematic dissemination of the information drawn from the best literature on irrigation, with special reference to more accurate estimates of crop water requirements by the collection of agro-meteorological data of the stations densely located on the territory. The agro-meteorological data should be archived in a data bank and disseminated by a responsible agency. For example, weekly bulletins may be prepared and adequately disseminated through the participation of associations, cooperatives, entrepreneurs and other technical offices.

A quality jump in the dissemination of information is possible through a dedicated INTERNET site supporting an interactive programme using the area of the farm, data on the crops to be irrigated, hydraulic characteristics of the on-farm system, the water volume to be supplied and, in the case of trickle irrigation systems, the irrigation time, on the basis of the agro-meteorological data taken from the station closest to the farm, may be obtained.

VOLUMETRIC WATER CHARGES

The use of volumetric water charges in on-demand systems is indispensable. Otherwise, farmers would tend to leave open the hydrants for a period greater than needed and this will hamper the operation of the system and eventually generate salinity and waterlogging problems that will reduce the productivity of the land. In order to be able to measure the water that has been used every hydrant is equipped with a measuring device or water meter that registers the volume of water consumed. Volumetric charges are not only important in terms of the functioning of the system but is a socially fair method in the sense that the farmer pays for what he/she uses and represents an incentive for water conservation.

In most of the on demand irrigation systems every farm is equipped with one (or more) hydrant but when the farms are relatively small providing an hydrant for every farm becomes too expensive and several farms use the same hydrant. In such cases the volumetric reading correspond to a group of farmers and the volume consumed has to be distributed among them. The easiest way is that every farmer reads its consumption and provide this information to the management of the system. Usually there are some differences between the sum of the individual readings and the total reading for the period considered and the management distributes the difference among the group of farmers using some agreed criteria of proportionality (area or water consumed). In the rare cases that the group of farmers do not agree to provide their individual reading the management has no other practical option that to distribute the whole consumption according to some criteria (estimated consumption of the crops planted, area, or other).

Another way to solve the problem of sharing volumes among the farmers using the same hydrant is to use new delivery equipment where withdrawals are controlled by electronic card. A more detailed description of these devices is reported hereafter.

WATER METERS

Every hydrant is normally equipped with a water meter and other accessories (the pressure regulating valve, the flow limiting device and the cut-off valve). There are many types of water meters but those more commonly used in irrigation networks are of the propeller type where the turbine rotates at the a speed that is proportional to the flow velocity (Figure 79). The reader is normally of the cumulative type¹ so that the volume of water used in a given period is the result of the difference between the two readings (end and beginning of period). One possible problem of such system is that the farmer may realize at the end of the period that he/she has used more water than actually needed. To avoid overlooking the actual consumption he/she should annotated how much water is being used in every irrigation to avoid surprises at the end, however this is not a common practice.

The accuracy of the mechanical water meters is limited (normally with reading errors around 2 %) and the accuracy decreases with the time as the moving parts are subject to wear. For this reason water meters require frequent maintenance to keep their accuracy.

TYPES OF VOLUMETRIC CHARGES

The most common method of volumetric charging is to apply a unit value to the cubic meter of water provided such as US\$ 0.10/m³. Such value is normally calculated by dividing all the operation, maintenance and administration costs by the total number of cubic meters provided by the system. Obviously this value changes from year to year as both components of it can change considerably. Sometimes the unit value also includes an additional component which main purpose may be the creation of a reserve fund for rehabilitation or other purposes.

It is also frequent to apply *volumetric charges by blocks* in order to keep consumption within reasonable limits. When such method is applied the consumption which is considered normal is cost at a fair price, for instance for the first 5000 m³ ha⁻¹, US\$ 0.10/m³ for consumption between 5000 and 7000 m³ ha⁻¹ the price may increase to US\$ 0.13/m³ and for any consumption beyond 7000 m³ha⁻¹ the price may jump exponentially for instance: US\$ 0.25/m³, to reduce the chance that farmers may use water beyond this threshold. However the application of such method requires a detailed analysis of the crops prevailing in the system as some crops may need more water than others and the farmer should not be penalized for it. Applying the volumetric block pricing indiscriminately may lead to changes in the cropping pattern which may, or may not, be desirable.

¹ Some water meters give the instantaneous flow as well.

RECOVERY OF INVESTMENTS THROUGH THE VOLUMETRIC CHARGE

Countries practices different policies for the recovery of investments made in the irrigation systems. Such policies vary from of total subsidy to those that try to recover all the costs. Assuming that a country desires to recover at least a part of the investments the question arising is whether such costs should be included or not in the volumetric unit value applied. From a theoretical point of view the answer is it should not be included because that would lead to the inconsistency that those farmers planting crops with high water requirements will end paying more for the investments than those planting crops with low requirements. In the extreme a farmer that would not use any water a given year he/she would contribute nothing to the recovery of investment. Nevertheless, there are some few cases where for reasons of simplicity the recovery of investments is included as one more component of the volumetric unit value applied.

A more rational approach would be to recover the investments though a charge that is applied on per hectare basis while the variable costs (operation, maintenance and administration) are recovered through unit value applied for the cubic metre of water.

THE OPERATION, MAINTENANCE AND ADMINISTRATION COSTS

In a traditional surface irrigation system most of the operation and maintenance costs are constituted by the staff costs. In fact in open canal systems a large number of staff must dedicate their time to the opening and closing gates either to regulate the flows or to distribute the water to the farms. In an on-demand system such expenditures are very much reduced and the staff concerned with the actual operation of the system is limited to the pump stations operators and some supervisory staff at the central level.

Another advantage of on demand systems with respect to the traditional surface irrigation systems is that practically eliminates the conflicts between the staff responsible for distributing

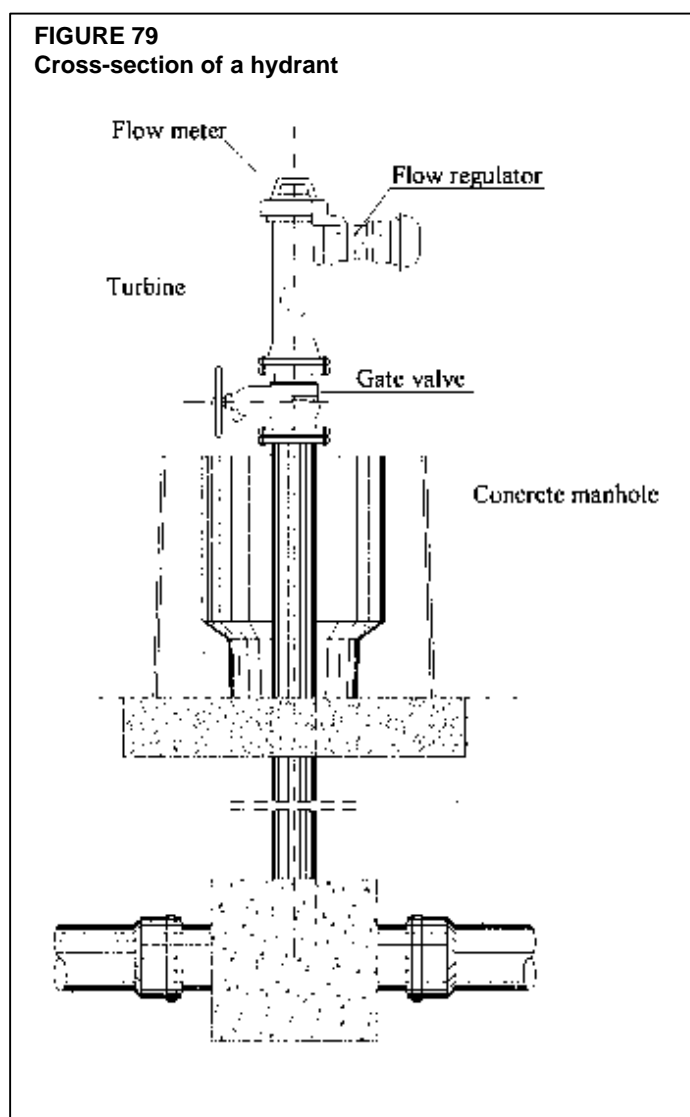

the water and the farmers that should receive the water, as is the farmer the person that open and closes the hydrant.

On the other hand the largest expenditure of on-demand systems is represented by the energy bill as the whole irrigation pipe network must be under pressure. Few on-demand systems have the fortune of having available the necessary pressure under natural conditions. One such case is The South Conveyor System of Cyprus, which is designed for on-demand operation, and is connected to the dam outlet where the topographic elevation permit generates enough pressure to keep the network working under the necessary conditions. In the rest of the cases the energy bill remains the most important component reaching values that represent 55-70% of the total O&M costs. Therefore if savings can be made in the energy required without sacrificing the quality of the operation the net savings for the farmer can be important. In this sense the analysis of the performance described in Chapter 5 can be useful to diagnose how well designed the system is and in particular the effectiveness of the pumping station.

In general the water charges due to O&M are somewhat higher than in open canals systems but the quality of the water service is clearly superior. The fact that the farmer can apply the water when the crops needs it has a positive impact in the yields which clearly offset the greater water charges.

In any case, the impact of the water charges in the total production costs of a given crop are in general small (particularly if recovery of investments is not included) and often they are less than 5 % and rarely exceed 10 %.

THE MAINTENANCE OF THE PUMPING STATIONS AND RELATED DEVICES

The ordinary maintenance of the pumping station concerns the equipment and all civil engineering works in the plant. Some general rules to ensure an adequate maintenance are listed hereby.

Flow and pressure meters:

- Checking, at least once per day, the transmitter efficiency, to be sure that the quantity recorded by the recorder coincides with that measured by the instruments;
- Checking, at least once every three months, the calibration of equipment and execute adjustment if required;

Pumps:

- Regulation of the electric pump operation in relation to water discharge
- Inspection, at least once per day, of electric pumps to ascertain any malfunctioning (either clogging or blocking of the impeller, jamming of flap valve, leak in the delivery pipe, defective float switches, etc...)
- Checking, at least once per day, the regular position of floats or sensors as well as their proper operation to start and stop the electric pump itself;
- Checking, at least once per month, the degree of wear of the electric pump mechanical equipment and fittings
- Periodical cleaning has to be provided to ensure the proper operation of all lifting stations, including stand-by pumps.

Compressors:

- Inspecting, at least once per day, the electric compressors and the pipeline of pneumatic circuits to be sure that there are no air leaks;
- Checking, at least once per month, the perfect efficiency of electric and pneumatic circuits and of their organs with special reference to the pressure gage.
- Checking, at least once per month, the degree of wear of the electric compressor mechanical organs;
- Checking and cleaning, at least once per month, the suction filter.

Switchboards:

- Inspecting, at least once per month, the switchboards and execute repairing if required.
- If the inverter is installed, the switchboard has to be placed in a room with air conditioning system in order to avoid damages to it, due to air temperature.

Ancillary works:

- Annual painting of metal structures;
- Two-yearly painting of all building works;
- Periodical manoeuvres of existing gates and valves in the system to ensure their proper operation.

THE MAINTENANCE OF THE IRRIGATION NETWORK

In general the maintenance of the irrigation network does not require major maintenance works if the construction was done according to specifications and suitable materials were selected. Nevertheless possible problems arising from certain characteristics of the water quality (abrasion, high calcium carbonate, etc..) may need particular attention.

The most common problem of the pipe networks is the appearance of leaks mostly due weathering of the joints or misplacement of them. Accidental breakage of pipes sometimes happens due to the use of earth movement equipment in construction sites near the pipes.

The most critical point in the whole network is the hydrant and all the accessories included there. Hydrants must be reliable and robust to avoid the possible manipulations of farmers which may alter their characteristics.

The most common problem is their partial or total breakage due to wrong operations with tractors or other agricultural machinery. To avoid such problems is a good practice to protect them with some concrete structures placed around them.

TOWARDS THE USE OF TRICKLE IRRIGATION AT THE FARM LEVEL IN ON-DEMAND IRRIGATION SYSTEMS

Many on-demand irrigation systems originally designed for sprinkler irrigation are gradually being replaced by trickle irrigation methods. The implications for on-demand systems are several:

- the pressure head required is considerably lower than for sprinkler methods. It leads to improve the hydraulic performance of the system when pressure deficits occur at the hydrant level for on-farm sprinkler methods;
- trickle methods require daily operation and this has some implications in the design parameters of the system (see the analysis in Annex 1);
- the daily required discharge is generally lower than for sprinkler methods. It leads to lower head losses in the system and, consequently, higher pressure heads at the hydrant level.

This progressive change in many on-demand systems has positive implications for the operation of the system and the analysis of such situations can be facilitated by the COPAM package.

NEW TRENDS AND TECHNOLOGIES OF DELIVERY EQUIPMENT

The ever-increasing water demand for irrigation, together with the growing difficulties and costs of developing new resources, make it necessary to assist managers of irrigation systems for a better use of water. In this perspective, the new technologies may play an important role in improving both sound water use and management activities. In particular, new delivery devices have been developed in the last years (Antonello *et al.*, 1996; Megli, 1998) based on microprocessor systems that allow to regulate water withdrawals. They can be programmed with a number of functions, are mechanically resistant, reliable and not expensive.

These delivery devices are installed in the field and can be activated by an electronic card used by the farmer.

The unit located in the field is composed of a microprocessor, a hydraulic group consisting of a water meter with pulse emitter and a hydrovalve, an impulsive electric valve, a ring flow limiter, a delivery connection pipe, a stainless-steel box (see Figure 80). It is supplied with a lithium battery having 10-15 year lifetime under normal operating conditions.

The electronic card is composed by a plastic box in which a microprocessor, a real time clock, an alphanumeric display and two selection buttons are located.

Each electronic card is programmed (by the manager, through a user-friendly software package) in the management office at the beginning of the irrigation season. The seasonal available water volume may be pre-loaded on each card, as well as the maximum daily volume to be withdrawn and/or the maximum daily operating time.

The card may be removed during irrigation after the opening signal is transmitted. The closure will be done automatically in case of using the maximum daily volume or in case of exceeding the maximum operating time. In this way, nobody can steal or remove the card during its operation.

When farmers tend to withdraw too much water during the peak hours, the operating daily time interval may be pre-fixed, as well as the turn at the hydrant level. It will lead farmers to modify the flow hydrographs in such a way to be compatible with the system capacity.

After each irrigation, the residual volume appears on the display of the card. In this way the farmer may realize immediately if he/she is using more water than that actually needed by the crops.

The opening and closing time of the delivery device may be recorded on the card. It allows to define different tariff rules, for example, by reducing the night-time water price with respect to the day-time one. This solution may lead to a better distribution of deliveries during the day by avoiding excessive withdrawals during the daily peak hours.

Each electronic card is coded and, therefore, several farmers can take water from the same group by using different cards with different codes. In this case, no problems of water sharing among farmers will occur.

Finally, when such technology is used, the management activity is strongly simplified. In fact, farmers have an interest to address to the managing agency (not the opposite, as it happens when classical hydrants are used) for declaring and showing on the

card, the volume of water effectively used. Should they not address to the agency, they will be charged for the total volume pre-loaded on the card at the beginning of the irrigation season, even if they used less. Once the farmers exhaust the pre-loaded volume and need an additional one, they have to address again to the managing agency for requesting it. The manager can take the decision to supply the requested volume, if available, and he may also decide to charge a different price for it.

These devices are successful installed and used in some Southern Italy Irrigation schemes (Altieri *et al.*, 1999).

These types of delivery devices may greatly contribute to solve the problem of continuous and systematic interfacing between Irrigation Authorities and farmers. Managers of irrigation systems may also benefit, especially under conditions of limited water availability. Furthermore, a large number of reliable data may be available through these devices and they may be used both by managers and researchers for improving their knowledge on irrigation systems behaviour.

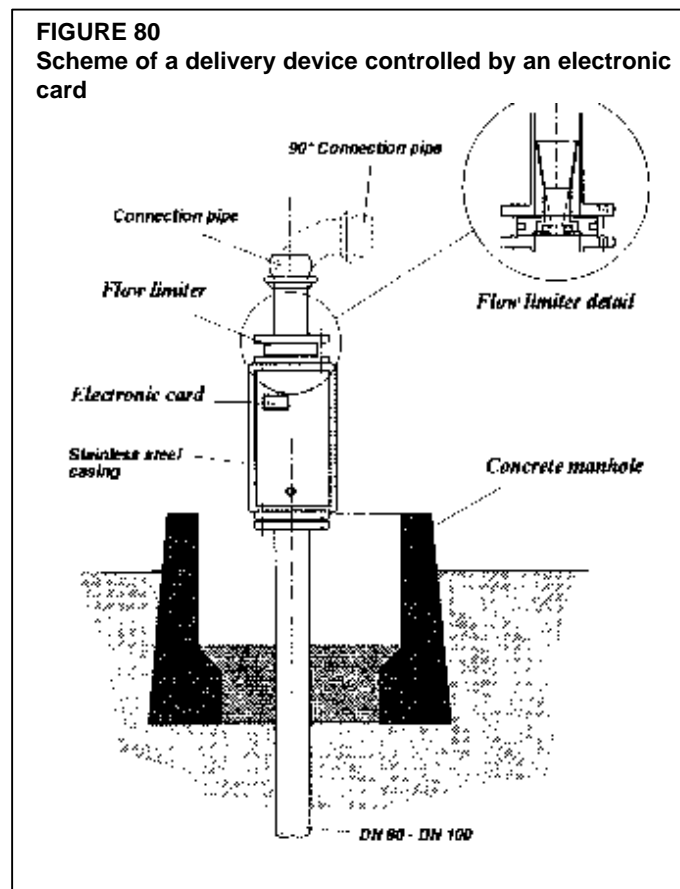

Bibliography

- Abdellaoui R. 1986. *Irrigation System Design Capacity for On Demand Operation*. Ph.D. Dissertation, Utah State University, Logan, USA.
- Abdelwahab C. 1992. *Analyse de fonctionnement d'un reseau collectif sous pression d'irrigation a la demande: Cas d'un reseau du périmètre Sinistra Ofant.*, M.S. Thesis, CIHEAM, Bari Institute, Bari, Italy.
- Ait Kadi M. 1986. *Optimization of Irrigation Pipe Network Layout and Design*. Ph.D. Dissertation, Utah State University, Logan, USA.
- Ait Kadi M., Abdellaoui R., Oulhaj A. and Essafi B. 1990. *Design of Large-scale Collective Sprinkler Irrigation Projects for On Demand Operation: A Holistic Approach*. Vol 1d. XIV Congress of ICID, Rio de Janeiro, Brazil. pp. 59-78.
- Allen R.G., Jensen M.E., Wright J.L. and Burman R.D. 1989. Operational estimates of reference evapotranspiration. *Agronomy Journal* **81**(4): 650-662.
- Allen R.G., Smith M., Perrier A. and Pereira L.S. 1994a. An update for definition of reference evapotranspiration. *ICID Bulletin* **43**(2): 1-34.
- Allen R.G., Smith M., Pereira L.S. and Perrier A. 1994b. An update for definition of reference evapotranspiration. *ICID Bulletin* **43**(2): 35-92.
- Alperovits E. and Shamir U. 1977. Design of optimal water distribution systems. *Water Resource Research* **13**(6): 885-900.
- Altieri S. 1995. Sinistra Ofanto irrigation scheme: management and maintenance problems. *Bonifica*. L.S. Pereira (ed.). No. 1-2: 40-47.
- Altieri S., Martire G. and Nardella L. 1999. Completamento funzionale del distretto 10 nel comprensorio Sinistra Ofanto. *Bonifica* No. 1: 51-56.
- Ben Abdellah D. 1995. *Extension de la programmation linéaire à l'optimisation des réseaux d'irrigation sous pression fonctionnant à la demande dans le cas de plusieurs régimes de débit*. M.S. Thesis, CIHEAM, Bari Institute, Bari, Italy.
- Benami A. and Ofen A. 1984. *Irrigation Engineering - Sprinkler, Trickle, Surface Irrigation - Principles, Design and Agricultural Practices*. IESP, Haifa, Israel.
- Bethery J. 1990. Réseaux collectifs d'irrigation ramifiés sous pression. Calcul et fonctionnement, *CEMAGREF Etudes* No. 6.
- Bethery J., Meunier M. and Puech C. 1981. *Analyse des défaillances et étude du renforcement des réseaux d'irrigation par aspersion*. Onzième Congrès de la CIID, question 36, pp. 297-324.
- Bianchi C. 1995. Controlling water in irrigation networks. *Water Management Europe* **4**(2): 65-73.
- Borland. 1990. *TURBO PASCAL Version 6.0, User's Guide*. Borland International Inc., Scotts Valley, California, USA.
- Borland. 1990. *TURBO PASCAL Version 6.0, Reference Guide*. Borland International Inc., Scotts Valley, California, USA.
- Bouchart F. and Goulter I. 1991. Reliability improvements in design of water distribution networks recognizing valve location. *Water Resource Research* **27**(12): 3029-3040.

- Bourla F.R. 1966. Evaluation des débits dans les réseaux d'irrigation. *La Houille Blanche* **5**: 543-552.
- Bouslimi M.A. 1997. *Examen des conditions de mise en oeuvre d'une conversion de la régulation d'une station de pompage par réservoir surélevé à la vitesse variable pour le gain d'énergie*, M.S. Thesis, CIHEAM, Bari Institute, Bari, Italy.
- Box G.E.P. and Jenkins G.M. 1976. *Time Series Analysis - Forecasting and Control*. Revised edition. Enders Robinson Editor, Oakland, California, USA.
- Caliandro A. 1995. Agronomic and agro-economic aspects of on-farm irrigation technologies - Synthesis of the communications. In: *46th International Executive Council, ICID/FAO, Session 1 on "The role of advanced technologies in irrigation and drainage systems in making effective use of scarce water resources*, 12-13 September 1995, FAO, Rome.
- Caliandro A., Catalano M., Rubino P. and Boari F. 1990. Research on the suitability of some empirical methods for estimating the reference evapotranspiration in Southern Italy. In: *Proceedings of the First Congress of the European Society of Agronomy*. A. Scaife (ed.). Paris. **2**: 65-68.
- Castorani A. and Piccinni A. F. 1991. Pipe network verification by the virtual piezometric height method. *Proceedings of the XXIV IAHR Congress*, Madrid, D, 125-132.
- Cavazza L. and Ravelli F. 1979. Curve di risposta all'irrigazione per le colture erbacee di maggiore interesse. *Agricoltura ricerca* **6**: 27-40 .
- Consorzio di Bonifica per la Capitanata (CBC). 1984. *Cinquant'anni di bonifica nel Tavoliere*. Ed. Bastogi, Foggia, Italy.
- CEMAGREF. 1983. Calcul des réseaux ramifiés sous pression, Etude n. 506, Groupement d'Aix-en-Provence, France.
- CEMAGREF. 1990. Logiciel XERXES-RENFORS, Optimisation économique des réseaux ramifiés sous pression, Groupement d'Aix-en-Provence, France.
- Ciollaro G., Lamaddalena N. and Altieri S. 1992. Indagini preliminari sui consumi idrici in un comprensorio irriguo. In: *Giornate di Studio sul Tema: La misura nella Gestione delle Infrastrutture Idrauliche*. Caserta (NA), 17-18 February, Ed. CUEN, Naples, Italy. pp. 151-169.
- Ciollaro G., Lamaddalena N. and Altieri S. 1993. Analisi comparativa fra consumi idrici stimati e misurati in un distretto irriguo dell'Italia meridionale. *AIGR- Rivista di Ingegneria Agraria* **4**: 234-243.
- Clément R. 1966. Calcul des débits dans les réseaux d'irrigation fonctionnant à la demande. *La Houille Blanche* **5**: 553-575.
- Clément R. and Galand A. 1979. *Irrigation par aspersion et réseaux collectifs de distribution sous pression*. Eyrolles Editeur, Paris. 182 p.
- Clemmens, A.J. 1987. Delivery system schedules and required capacities. In: *Planning, Operation, Rehabilitation and Automation of Irrigation Water Delivery Systems*. D.D. Zimbelman (ed.). ASCE, New York. pp. 18-34.
- CTGREF Division Irrigation. 1974. *Lois de probabilité des débits de pointe d'un réseau d'irrigation collectif par aspersion. Loi de Clément. Vérification à partir d'enregistrements*. Note Technique 2.
- CTGREF Division Irrigation. 1977. *Ajustement expérimental de la formule de Clément pour un réseau collectif d'irrigation par aspersion*. Note Technique 4.
- CTGREF Division Irrigation. 1979. *Programme ICARE - Calcul des caractéristiques indicées*. Note Technique 6.
- Di Santo A. and Petrillo A. 1980a. I modelli matematici per il calcolo delle reti irrigue - confronto fra i vari metod. In: *Proceeding of Giornate di cooperazione italo-ungherese su scienza e tecnica*, 2-3 December. Bari, Italy. pp. 1-17.

- Di Santo A. and Petrillo A. 1980b. Un modello matematico per il calcolo delle reti irrigue. In: *Atti e Relazioni dell'Accademia Pugliese delle Scienze XXXVIII*.
- D'Urso G., Menenti M. and Santini A. 1995. Remote sensing and simulation modelling for on-demand irrigation systems management. In: *46th International Executive Council, ICID/FAO, Workshop on "Irrigation scheduling: from theory to practice"*, n. 16, 12-13 September. FAO-Rome.
- El Alloumi K. 1993. *Application de la méthode d'optimization des diamètres en cas de plusieurs régimes de débits au dimensionnement*. M.S. Thesis, CIHEAM, Bari Institute, Bari, Italy.
- El Hajjaji M. 1992. *Indicateurs de performance et de conception des systèmes d'irrigation. Application aux systèmes de Pouilles*. M.S. Thesis, CIHEAM, Bari Institute, Bari, Italy.
- El Kellouti M. 1991. *Analyse de certains indicateurs de performance des systèmes d'irrigation de la région de Pouilles*. M.S. Thesis, CIHEAM, Bari Institute, Bari, Italy.
- El Madani M. 1991. *Optimization des réseaux ramifiés de distribution d'eau sous pression dans le cas de plusieurs régimes de débits*. M.S. Thesis, CIHEAM, Bari Institute, Bari, Italy.
- El Yacoubi Z. 1994. *Développement d'un modèle de génération des régimes de débit dans un réseau d'irrigation fonctionnant à la demande*. M.S. Thesis, CIHEAM, Bari Institute, Bari, Italy.
- FAO. 1977. Crop water requirements. J. Doorenbos and W.O. Pruitt. *Irrigation and Drainage Paper 24*. FAO, Rome.
- FAO. 1979. 1979. Yield response to water. J. Doorenbos and A.H. Kassam. *Irrigation and Drainage Paper 33*. FAO, Rome.
- FAO. 1984. Mathematical models in hydrology. R.T. Clarke. *Irrigation and Drainage Paper 19*. FAO, Rome.
- FAO. 1988. Design and optimization of irrigation distribution networks. Y. Labye, M.A. Olson, A. Galand and N. Tsiourtis. *Irrigation and Drainage Paper 44*. FAO, Rome.
- Fereres E., Goldfien R.E. and Pruitt W.O. 1981. The irrigation management program: a new approach to computer assisted irrigation scheduling. *Proceedings of the ASCE Congress on Irrigation Scheduling for Water and Energy Conservation in the 80's*. St. Joseph, Michigan, USA.
- Fujiwara O. and Tung H. 1991. Reliability improvement for water distribution networks through increasing pipe size. *Water Resource Research 27*(7): 1395-1402.
- Galand A., Meunier M. and Seunier M., 1975. Simulation du fonctionnement d'un réseau d'irrigation par aspersion. In: *Rapports du 9^e congrès de la CIID*, Moscou, 32, 1-25.
- Goulter I. 1987. Current and future use of systems analysis in water distribution network design. *Civil Engineering Systems 4*(4): 175-184.
- Goulter I. 1992. Systems analysis in water distribution network design: from theory to practice. *Journal of Water Resources Planning and Management 118*(3): 238-248.
- Goulter I. and Bouchard F. 1990. Reliability-constrained pipe network model. *Journal of Hydraulic Engineering, ASCE 116*(2): 211-229.
- Hashimoto T. 1980. *Robustness, Reliability, Resiliency and Vulnerability Criteria for Planning Water Resources Systems*. Ph.D. Dissertation, Cornell University.
- Hashimoto T., Stedinger J.R. and Loucks D.P. 1982. Reliability, resilience and vulnerability criteria for water resources system performance evaluation. *Water Resources Research 18*(1): 14-20.
- Khadra R. 1999. *Performance Analysis of On-demand Irrigation Systems: Interface with GIS*. M.S. Thesis, CIHEAM, Bari Institute, Bari, Italy.
- Karmeli D., Gadish I. and Meyers S. 1968. Design of optimal water distribution networks. *Journal of Pipeline Division, ASCE 94*(1): 1-9.

- Knuth D.E. 1981. *Seminumerical Algorithms*. 2nd ed. Vol. 2 of The Art of Computer Programming. Ed. Addison-Wesley, New York.
- Indelicato S. 1988. Sviluppo dell'irrigazione e problemi tecnici delle reti irrigue. In: *Giornata di studio per l'ecologia e l'ambiente: il trasporto delle acque nel settore irriguo, refluo e potabile*. Bari, Italy. pp. 97-108.
- Jagdish S. Rustagi. 1994. *Optimization Techniques in Statistics*. Academic Press, San Diego, California, USA.
- Journel A.G. and Huijbregts Ch. J. 1991. *Mining Geostatistics*. Academic Press., San Diego, California, USA.
- Labya Y. 1966. Etude des procédés de calcul ayant pour but de rendre minimal le coût d'un réseau de distribution d'eau sous pression. *La Houille Blanche* **5**: 577-583.
- Labye Y. 1981. Iterative Discontinuous method for networks with one or more flow regimes. In: *Proceedings of the International Workshop on Systems Analysis of Problems in Irrigation, Drainage and Flood Control*. New Delhi. 30 November – 14 December. pp. 31-40.
- Labye Y. and Montgolfier J.M. 1971. Modèle de simulation du comportement d'un réseau sous pression devant fonctionner à la demand. In: *Rapports du 8^e journées européennes de la CIID*. Association française pour l'étude de la irrigation et du drainage, 35, 1-16.
- Lamaddalena N. 1995. Un modello di simulazione per l'analisi del funzionamento delle reti irrigue collettive. *AIGR - Rivista di Ingegneria Agraria* **4**: 221-229.
- Lamaddalena N. 1995. Analisi del funzionamento dei sistemi irrigui collettivi. *Rivista di Irrigazione e Drenaggio* **2**: 18-26.
- Lamaddalena N. 1996. Sulla ottimizzazione dei diametri in una rete irrigua con esercizio alla domanda. *AIGR - Rivista di Ingegneria Agraria* **1**: 12-19.
- Lamaddalena N. 1997. *Integrated simulation modeling for design and performance analysis of on-demand pressurized irrigation systems*. Ph.D. Dissertation. Technical University of Lisbon, Lisbon.
- Lamaddalena N. and Ciollaro G. 1993. Taratura della formula di Clément in un distretto irriguo dell'Italia meridionale. In: *Atti del V Convegno Nazionale AIGR. su Il ruolo dell'ingegneria per l'agricoltura del 2000*. Maratea, Italy. 7-11 June. Ed. Europa (Potenza). pp. 101-110.
- Lamaddalena N. and Pereira L.S., 1998. Performance analysis of on-demand pressurized irrigation systems. In: *Water and Environment: Innovative Issues in Irrigation and Drainage*. L.S.Pereira and J. Gowing (eds.). E&FN Spon. pp. 247-255.
- Lamaddalena N. and Piccinni A.F. 1993. Sull'utilizzo delle curve caratteristiche indicizzate di una rete irrigua per il dimensionamento degli impianti di sollevamento. *AIGR - Rivista di Ingegneria Agraria* **3**: 129-135.
- Lamaddalena N., Ciollaro G. and Pereira L.S. 1995. Effect of changing irrigation delivery schedules during periods of limited availability of water. *Journal of Agricultural Engineering Research* **61**: 261-266.
- Lamaddalena N., Pereira L.S. and Ait Kadi M. 1998. Modeling approach for design and performance analysis of on-demand pressurized irrigation systems. *Proceedings of 7th International Conference on Computer in Agriculture*. ASAE - Orlando (Florida), 26-30 October.
- Lansley K.E. and Mays L.W. 1989. Optimization model for water distribution system design. *Journal of Hydraulic Engineering*, ASCE **115**(10).
- Lansley K.E. and Basnet C. 1990. A design process for water distribution systems including optimization, *Proceedings of Water Resources Infrastructure Conference, Needs, Economics and Financing*. J. Scott and M. Khambilvardi (eds.). ASCE, New York. pp. 41-47.
- Lebdi F., Tarhouni J. and Elarbi M.S. 1993. Simulation et diagnostic des réseaux hydrauliques: une méthode modifiée des caractéristiques indicées. *Les Annales Maghrébines de l'Ingénieur* **7**(2): 53-64.

- Lee Cesario, Brasher P.T., Buttle J.L., Howard C.D.D., Kroon J., Morey E.F., Robinson M.P. Jr, Sarikelle Simsek, Uri Shamir, Topping R.E., Velon J.P., Walsky T. and Wood D.J., 1989. *Distribution Network Analysis for Water Utilities*. American Water Works Association, Manual of Water Supply Practices, Denver, Colorado, USA.
- Lencastre A. 1987. *Handbook of Hydraulics Engineering*. Ellis Horwood, Chichester, UK.
- Liang T. 1971. Design of conduit system by dynamic programming, *Journal of Hydraulic Division, ASCE* **97**(3): 383-393.
- Linoli A. 1981. La distribution á la demanda est elle encore valable, *ICID Bulletin* **30**(1).
- Maidment D.R. and Hutchinson P.D. 1983. Modeling water demands of irrigation projects, *Journal of Irrigation and Drainage Division, ASCE* **109**(4): 405-418.
- Malossi D. and Santovito L. 1975. Progetto esecutivo dell'adduttore e della rete irrigua a servizio della zona bassa del comprensorio in Sinistra Ofanto - Relazione generale. Consorzio per la bonifica della Capitanata, Foggia, Italy.
- Marchi E. and Rubatta A. 1981. *Meccanica dei fluidi; Principi ed applicazioni*. Ed. UTET, Turin, Italy.
- Mechin Y. and Perard G. 1960. *L'équipement en matériel mobile considéré comme base du calcul des débit transportés dans les diverses branches d'un réseau d'irrigation par aspersion*. Rapports particuliers présentés par l'Association Française des Irrigations et du Drainage à Madrid en 1960. The Central Electric Press, Kamla Nagar, Delhi, India.
- Minoux M. 1983. *Programmation Mathématique - Théorie et Algorithmes*. Vol. 1 and 2, Dunod Ed., Paris.
- Morgan D. and Goulter I. 1985. Optimal urban water distribution design, *Water resource research*, 21(5), 642-652.
- Nerilli E. 1996. *Analisi del funzionamento di un sistema irriguo collettivo in pressione durante periodi di limitata disponibilità idrica*. M.S. Thesis, CIHEAM, Bari Institute. *Bonifica* **3**: 25-49.
- Pereira L.S. and Lamaddalena N. 1989. Miglioramento della gestione dei sistemi irrigui: sviluppo di una rete banca-dati con indicatori. *Rivista di Irrigazione e Drenaggio* **4**: 207-212.
- Pereira L.S. and Teixeira J.L. 1994. Modeling for irrigation delivery scheduling: simulation of demand at sector level with models ISAREG and IRRICEP. In: *Irrigation Water Delivery Models*. J.C. Skutsch (ed.). *Water Report* **2**: 13-32, FAO, Rome.
- Perold, R. P. 1974. Economic pipe sizing in pumped irrigation systems. *Journal of Irrigation and Drainage Division, ASCE* **100**(IR4): 425-441.
- Piccolo D. and Vitale C. 1984. *Metodi statistici per l'analisi economica*. Ed. Il Mulino, Bologna, Italy.
- Prajamwong S. 1994. *USU Command Area Decision Support Model*. Ph.D. Dissertation. Utah State University, Loan, USA.
- Press W.H., Flannery B.P., Teukolsky S.A. and Vetterling W.T. 1989. *Numerical Recipes in Pascal - The Art of Scientific Computing*. Cambridge University Press, Cambridge.
- Quindry G., Brill E. and Liebman J. 1981. Optimization of looped water distribution systems. *Journal of Environmental Engineering Division, ASCE* **107**(4): 665-679.
- Rossman Lewis A. 1993. *EPANET Users Manual*. US Environmental Protection Agency, Drinking Water Research Division, Risk Reduction Engineering Laboratory, Cincinnati, Ohio, USA.
- Rossi F. and Salvi R. 1983. *Manuale di Ingegneria Civile*. Ed. Cremonese A., Rome.
- Santini A. 1988. Impianti irrigui - relazione generale, In: *Atti del Congresso Nazionale dell' A.I.I. su Controllo dei grandi impianti idrici per un migliore utilizzo delle acque*. Taormina, Italy **3**: 98-120.

- Schaake J. and Lai D. 1969. Linear programming and dynamic programming application of water distribution network design. *Report 116*, MIT Press, Cambridge, Mass, USA.
- Smith M., Allen R.G., Monteith J., Perrier A., Pereira L.S. and Segeren A. 1991. Report of the Expert Consultation on Procedures for the Revision of FAO Guidelines for Prediction of Crop Water Requirements. FAO, Rome. 54 p.
- Su Y., Mays L., Duan N. and Lansey K. 1987. Reliability based optimization for water distribution systems. *Journal of Hydraulic Engineering, ASCE* **113**(12): 589-596.
- Schildt H. 1986. *Advanced in Turbo Pascal - Programming and Techniques*. Osborne McGraw-Hill, Berkeley, California, USA.
- Sharp B.B. 1981. *Water Hammer, Problems and Solutions*. Edward Harnold, London, UK.
- Smith M. 1989. Manual for Cropwat - A Computer Program for IBM-PC or Compatibles - Version 5.5, FAO, Rome.
- Teixeira J.L., Farrajota M.P. and Pereira L.S. 1995. PROREG: a simulation software to design demand in irrigation projects. In: *Crop-Water-Simulation Models in Practice*. L.S. Pereira, B.J. van den Broek, P. Kabat and R.G. Allen. Wageningen Press. pp. 273-285.
- Teixeira J.L., Paulo A. M. and Pereira L.S. 1996. Simulation of irrigation demand hydrographs at sector level. *Irrigation and Drainage Systems*. Kluwer Academic Publishers, The Netherlands. **10**: 159-178.
- Templeman A. 1982. Discussion of 'Optimization of looped water distribution systems' by *Quiry et al.*, *Journal of Environmental Engineering Division, ASCE* **108**(3): 599-602.
- Tournon G. 1991. Valutazioni sull'utilizzazione dei risultati della ricerca al fine della progettazione irrigua sotto l'aspetto ingegneristico. *Bonifica*, Nos. 2-3.
- US Bureau of Reclamation. 1967. *Canals and Related Structures - Design Standards*, n. 3, DS35/12/8/67, Denver.
- Villalobos F. J. and Fereres E. 1989. A simulation model for irrigation scheduling under variable rainfall. *ASCE, Soil and Water Division* **32**(1): 181-188.
- Walker W.R., Prajamwong S., Allen R.G. and Merkley G.P. 1995. USU command area decision support model - CADSM, In: *Crop-Water-Simulation Models in Practice* L.S. Pereira, B.J. van den Broek, P. Kabat and R.G. Allen (eds.). Wageningen Press. pp. 231-271.
- Walski T. 1985. State-of-the-art: pipe network optimization, *Journal of Computer Application in Water Resources*. H.C. Torno Ed., ASCE. pp. 559-568.
- Walsky T., Brill E., Gessler J., Goulter I., Jeppson R., Lansey K., Lee H-L., Liebman J., Mays L., Morgan D. and Orsmbee L. 1987. Battle of the network models: epilogue. *Journal of Water Resource Planning and Management, ASCE* **113**(2): 191-203.
- Walters G. 1988. Optimal design of pipe networks: A review. *Proceedings of 1st International Conference on Computers Methods and Water Resource in Africa*. Computational Hydraulics, Computational Mechanics Publications and Springer Verlag, Southampton, UK. 2: 21-32.
- Zaccaria D., 1998. *Reliability Analysis of an On-demand Irrigation System*. M.S. Thesis, CIHEAM, Bari Institute, Bari, Italy.

Annex 1

Validation of the 1st Clément model

The Clément model, like all other models, only offers a schematic representation of an actual network. Therefore, it must be adjusted and/or calibrated by introducing field data relative to existing networks. In particular, values of the parameter "r" should be, whenever possible, selected for homogeneous regions and for particular crops. An example of the field calibration of the Clément model, for an Italian irrigation network, is reported below, after a short presentation of the theoretical approach.

THEORETICAL APPROACH

Remembering the following relationship (see the first Clément model in chapter 3):

$$p = \frac{q_s A}{r R d} \quad (A1)$$

the relationship

$$Q_k = R p d + U(P_q) \sqrt{R p (1-p) d^2} \quad (A2)$$

becomes¹:

$$Q_k = \frac{q_s A}{r} \left[1 + U(P_q) \sqrt{\frac{r d}{q_s A} - \frac{1}{R}} \right] \quad (A3)$$

1

$$\begin{aligned} Q_k &= d \left[R \frac{q_s A}{r R d} + U(P_q) \sqrt{R \frac{q_s A}{r R d} \left(1 - \frac{q_s A}{r R d}\right)} \right] = d \left[\frac{q_s A}{r d} + U(P_q) \sqrt{\frac{q_s A}{r d} \left(\frac{r R d - q_s A}{r R d}\right)} \right] \\ &= d \left[\frac{q_s A}{r d} + U(P_q) \sqrt{\frac{q_s A r R d - (q_s A)^2}{r^2 d^2 R}} \right] = d \left[\frac{q_s A}{r d} + U(P_q) \sqrt{\frac{q_s A}{r d} - \frac{(q_s A)^2}{r^2 d^2 R}} \right] \\ &= d \left[\frac{q_s A}{r d} + U(P_q) \sqrt{\frac{q_s A}{r d} - \left(\frac{q_s A}{r d}\right)^2 \frac{1}{R}} \right] \quad \text{by taking out the term } \frac{q_s A}{r d} \text{ we have:} \\ Q_k &= d \frac{q_s A}{r d} \left[1 + U(P_q) \sqrt{\frac{r d}{q_s A} - \frac{1}{R}} \right] \end{aligned}$$

This formula indicates that the discharge during the peak period fits a Gaussian distribution having mean

$$\mu_{th} = \frac{q_s A}{r} \quad (A4)$$

and standard deviation

$$\sigma_{th} = \frac{q_s A}{r} \sqrt{\frac{r d}{q_s A} - \frac{1}{R}} \quad (A5)$$

where the subscript "th" indicates these are theoretical values.

To verify the applicability of the 1st Clément formula a recording flow meter is installed at the upstream end of the network. From the discharges recorded in field during the peak period, selecting the classes of discharges and the appropriate time interval for the observations, it is possible to build up the histogram of frequencies (see examples in Figures A4 and A5).

A histogram gives the number NQ_i of discharges included in each class, whose central value is Q_i . Then the mean (μ_{exp}) and the standard deviation (σ_{exp}) are computed:

$$\mu_{exp} = \frac{\sum_{i=1}^{NQ_T} NQ_i Q_i}{NQ_T} \quad (A6)$$

$$\sigma_{exp} = \sqrt{\frac{\sum_{i=1}^{NQ_T} NQ_i (Q_i - \mu_{exp})^2}{NQ_T - 1}} \quad (A7)$$

where $NQ_T = \sum_i NQ_i$ and the subscript "exp" indicates that these are experimental values.

From all the discharges withdrawn in the field during the peak period, it is possible to identify one or more populations of discharges¹. For the population which characterizes the peak water use, it is possible to estimate the parameter r . This parameter behaves like an adjusting parameter (CTGREF, 1977; Bethery 1990).

To compute r , it is assumed that

$$\mu_{th} = \mu_{exp} \quad (A8)$$

$$\sigma_{th} = \sigma_{exp} \quad (A9)$$

The following steps are required. First, μ_{exp} is computed from all experimental values relative to the whole peak period of 10 days and to the whole day (from 0 to 24 hours). This leads to a first estimation of the mean specific continuous discharge (q_s) withdrawn 24/24 hours. From the relationships (A4), (A6) and (A8) we have:

$$\left[\mu_{exp} \right]_0^{24} = \frac{\sum_{i=1}^{NQ_T} NQ_i Q_i}{NQ_T} = \frac{q_s A}{r} \quad (A10)$$

¹ As for the case study reported hereafter two populations were identified, one concerning daytime irrigation, the other nighttime irrigation.

Once $t'/t = 24$ hours, in this first approach $r = 1$. Therefore, the specific continuous discharge is computed:

$$q_s = \frac{[\mu_{\text{exp}}]_0^{24}}{A} \quad (\text{A11})$$

In a second step, the theoretical and the experimental standard deviations are calculated through the relationships (A5) and (A7) respectively. These deviations being different, their relative difference is then computed:

$$\delta\sigma = \frac{\sigma_{\text{exp}} - \sigma_{\text{th}}}{\sigma_{\text{exp}}} \quad (\text{A12})$$

When $\delta\sigma \gg 0$, since the objective is to characterize the operation of the system for the peak period, the night-time discharges can be excluded. A new histogram is then built for the discharges observed during a period smaller than 24 hours (i.e., between the hours $t_{\text{in}} = 4$ a. m. and $t_{\text{fin}} = 12$ pm, of each day during the peak period). Thus, new values for NQ_i and n result in a new $[\mu_{\text{exp}}]_{t_{\text{in}}}^{t_{\text{fin}}}$ (Eq. A6). Since q_s is now known (Eq. A11) it is possible to compute r :

$$r = \frac{q_s A}{[\mu_{\text{exp}}]_{t_{\text{in}}}^{t_{\text{fin}}}} = \frac{[\mu_{\text{exp}}]_0^{24}}{[\mu_{\text{exp}}]_{t_{\text{in}}}^{t_{\text{fin}}}} \quad (\text{A13})$$

Then, new values for σ_{th} and σ_{exp} are computed (Eqs. A5 and A7 respectively) and a new $\delta\sigma$ is calculated. An iterative procedure is then performed until the minimum value for $\delta\sigma$ is obtained. The corresponding value for r is then retained as the best estimation for the adjustment of the Clément formula.

Subsequently, through the integral curve of the Gaussian distribution, it is possible to determine, at the maximum recorded field discharge, the value of the cumulative probability and, consequently, the experimental $U(P_q)$.

APPLICATION

The calibration of the first Clément formula was performed for an Italian irrigation system: the district 4 of the "Sinistra Ofanto" irrigation scheme (Lamaddalena and Ciollaro, 1993), in the province of Foggia (Italy), run by the Consorzio di Bonifica of Capitanata (CBC, 1984). The scheme (Fig. A1), covering an area of about 22500 ha, is approximately triangular-shaped, confined in the south by the Ofanto river and in the southeast by the town of Cerignola. The system is divided into seven irrigation districts (numbered 4 to 10) which are, in turn, subdivided into sectors with surface areas ranging from 20 ha to 300 ha.

The irrigation districts are served by a storage and daily compensation reservoir supplied by a conveyance conduit, which originates from the Capacciotti dam (Fig. A1). The pressurized irrigation network in each district originates from these reservoirs and is designed for on-demand delivery scheduling (Malossi and Santovito, 1975).

District 4 (Fig. A1) was chosen for the survey since a calibrated flow meter is available at the upstream end of the distribution network. District 4 has a topographic area of 3256 ha, and is supplied by a storage and daily compensation reservoir having a capacity of 28000 m³ where the maximum water level is 143 m a.s.l. and the minimum water level is 139 m a.s.l.

FIGURE A1
The "Sinistra Ofanto" irrigation scheme

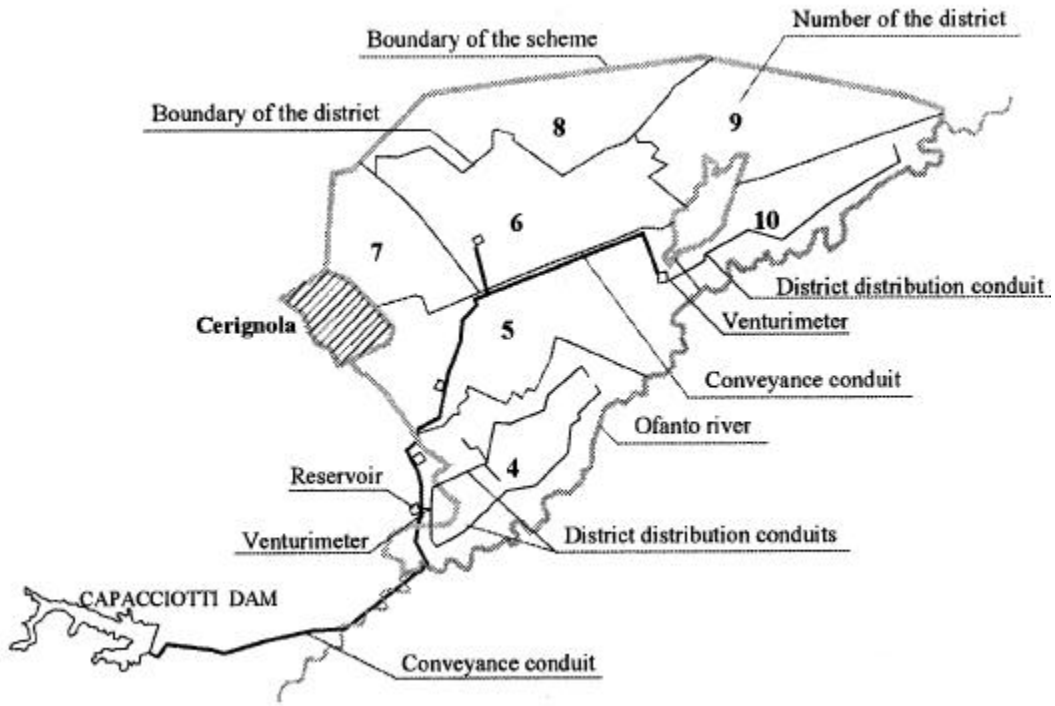
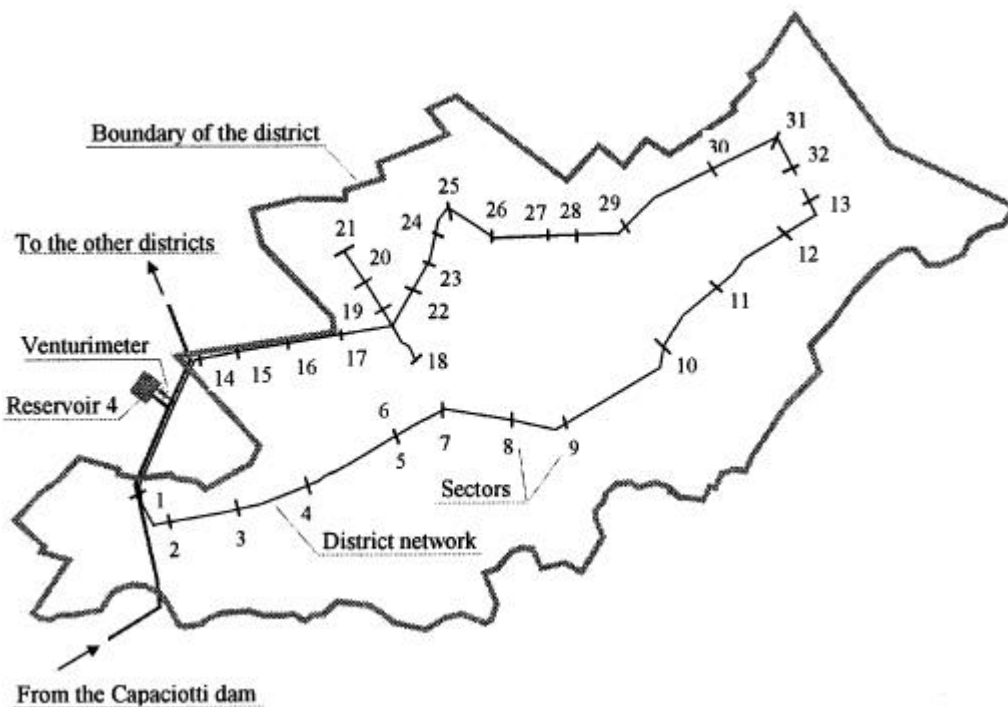

FIGURE A2
Layout of the district 4 network



The district distribution conduits consist of underground steel pipes starting with a diameter of 1200 mm. This conduit supply 32 sectors distribution systems (Fig. A2). A control unit is installed at the head of each sector and consists of a gate, a Venturi meter with recorder and a flow regulator. The sectors distribution networks serve the farms with hydrants having nominal discharge of 10 l s^{-1} . The District 4 network is composed of 903 nodes of which 660 with hydrants.

The discharges have been calculated with the Clément model while the diameters of the district distribution conduit have been calculated by applying linear programming techniques.

The calibration was performed for the year 1991 because during this year the district 4 irrigation system operated on-demand.

Discharge measurements using the recording Venturi meter were performed (Figure A3) at the inlet cross-section of the network, immediately downstream of the reservoir .

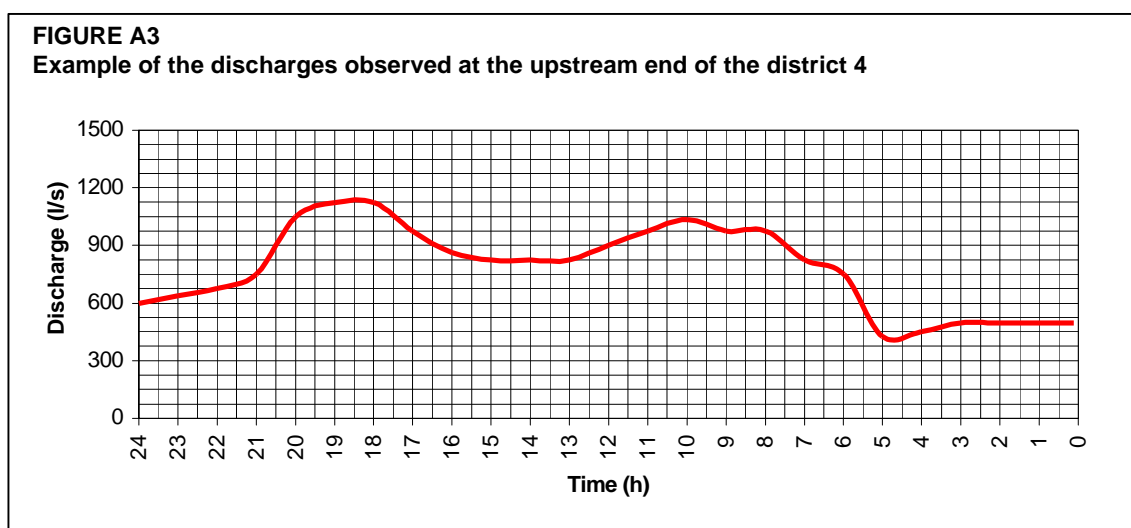

The irrigated areas and the corresponding crops grown during the 1991 irrigation season were calculated from the water user files available at the Irrigation Board. These data are reported in Table A1.

TABLE A1
Cropping pattern in the irrigation district during the 1991 irrigation season and scheduled in the year 1975

	SCHEDULED (1975)	SCHEDULED (1975)	1991	1991
CROPPING PATTERN	IRRIGATED AREA (ha)	IRRIGABLE AREA (ha)	IRRIGATED AREA (ha)	IRRIGABLE AREA (ha)
Vineyards	444.0	444.0	1325.9	1325.9
Olive trees	1149.0	1149.0	424.9	424.9
Orchards	21.0	21.0	71.2	71.2
Almond trees	-----	-----	5.0	5.0
Tomato	-----	-----	118.3	118.3
Potato	-----	-----	15.0	15.0
Asparagus	-----	-----	116.1	116.1
Vegetables	-----	-----	16.1	16.1
Wheat	416.0	925.0	-----	610.6
TOTAL	2030.0	2539.0	2092.5	2703.1

On the basis of the recorded discharges $q(t)$, the daily volumes, V_d (m^3), withdrawn by farmers during the observed months were computed from the relationship

$$V_d = \int_0^{24} q(t) dt \quad (A14)$$

In order to determine the seasonal peak period, the moving average method has been applied to the daily volumes, V_d , for periods of 5, 7 and 10 days. For these three time steps there are two peak periods falling at the end of June and at the first ten days of August. In both cases the delivered volumes (Table A2) are quite close, so in this case it was not possible to determine in a unique way the real peak period.

TABLE A2
Average value of the volumes (m^3) withdrawn during different peak periods

PEAK PERIODS	MOVING AVERAGE 5-DAY BASIS (m^3)	MOVING AVERAGE 7-DAY BASIS (m^3)	MOVING AVERAGE 10-DAY BASIS (m^3)
June 24 - July 3 August 3 - August 12			62223 61992
June 25 - July 1 August 4 - August 10		64030 64472	
June 25 - June 29 August 5 - August 9	64128 64719		

The method described in the previous section was applied to the 10-day peak periods identified in Table A2. After trying other values, the classes of discharges were defined for ranges of 60 l s^{-1} ($0 \div 60$; $60 \div 120$; $120 \div 180$; and so on). The histograms of frequencies for the two peak periods (Figures A4a and A5a) were developed considering hourly data (between 0 a.m. and 12 p.m.).

For the 10-day peak period from June 24 to July 3, the specific continuous discharge computed from the Equation (A11) is $q_s = 0.340 \text{ l s}^{-1} \text{ ha}^{-1}$. Results of computations for shorter intervals within the day are given in Table A3 and in Figure A4b. When $\delta\sigma$ reduced to 0.06 the parameter r became $r=0.86$. The peak specific discharge was $q_p = q_s/r = 0.395 \text{ l s}^{-1} \text{ ha}^{-1}$.

Similar results have been obtained considering data within the seasonal 10-day peak period ranging from August 3 to August 12 (Figure A5). In this case, the specific continuous discharge resulted to be $q_s = 0.350 \text{ l s}^{-1} \text{ ha}^{-1}$. Results of computations for shorter intervals within the day are given in Table A4 and in Figure A5b. When $\delta\sigma$ reduced to 0.01 the parameter r became $r=0.90$. The peak specific discharge resulted to be $q_p = q_s/r = 0.389 \text{ l s}^{-1} \text{ ha}^{-1}$.

TABLE A3
Value of the r parameter obtained for different time intervals. Period from June 24 to July 3 ($q_s = 0.340 \text{ l s}^{-1} \text{ ha}^{-1}$)

Initial Time	Final Time	μ_{exp}	μ_{th}	σ_{exp}	σ_{th}	$\delta\sigma$	r
0	24	708.15	708.15	278.95	194.76	0.30	1.00
2	24	734.86	734.86	268.73	197.95	0.26	0.97
4	24	766.97	766.97	251.91	201.67	0.20	0.93
6	24	807.30	807.30	222.40	206.19	0.07	0.88
8	24	823.67	823.67	220.70	207.97	0.06	0.86
10	24	812.61	812.61	224.60	206.77	0.08	0.88

FIGURE A4
 Discharge frequency histogram. Period from 24 June to 3 July

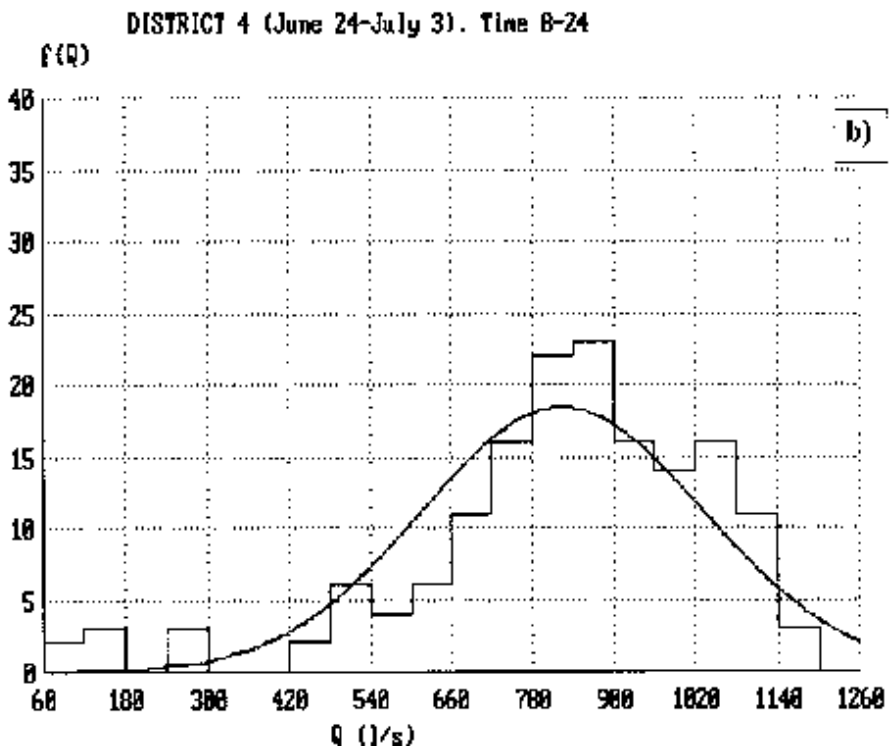
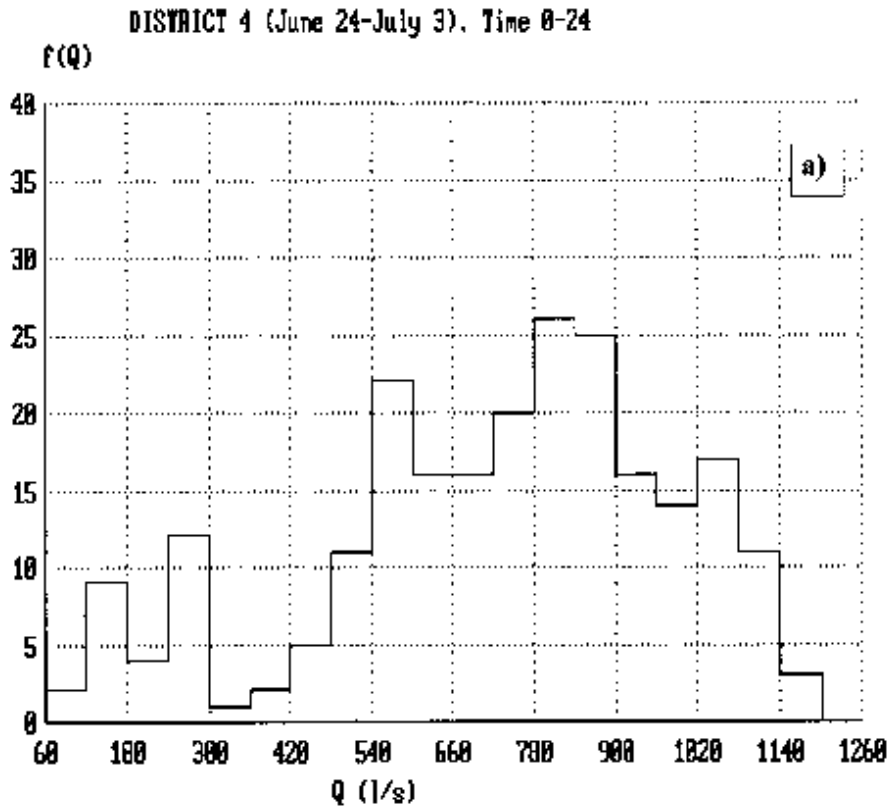

FIGURE A5
Discharge frequency histogram. Period from 3 August to 12 August

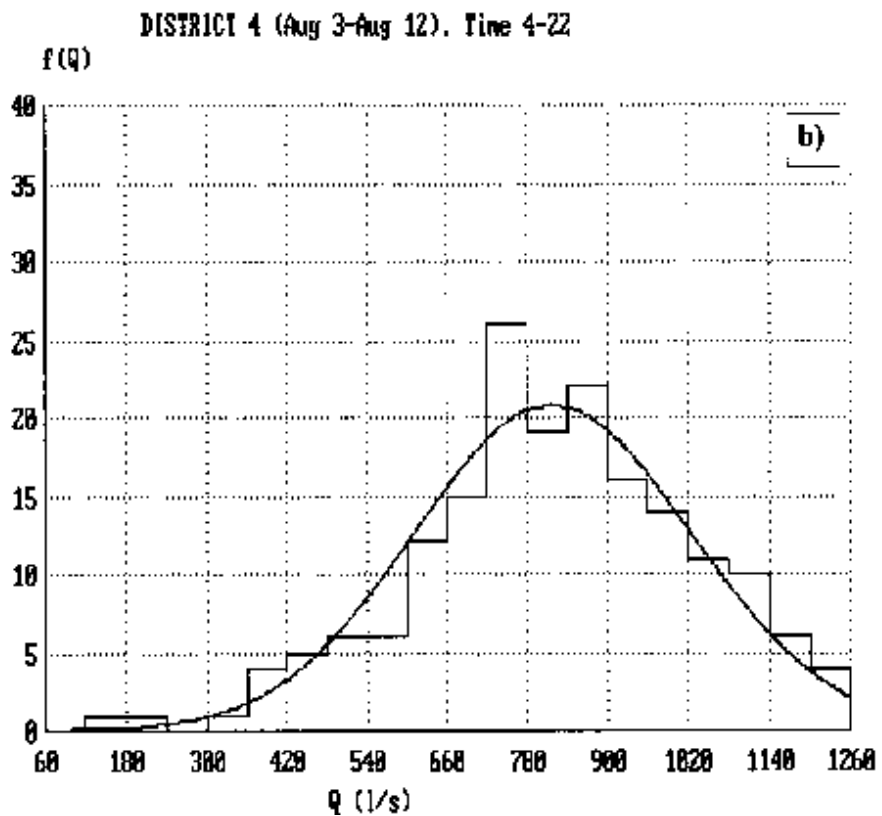
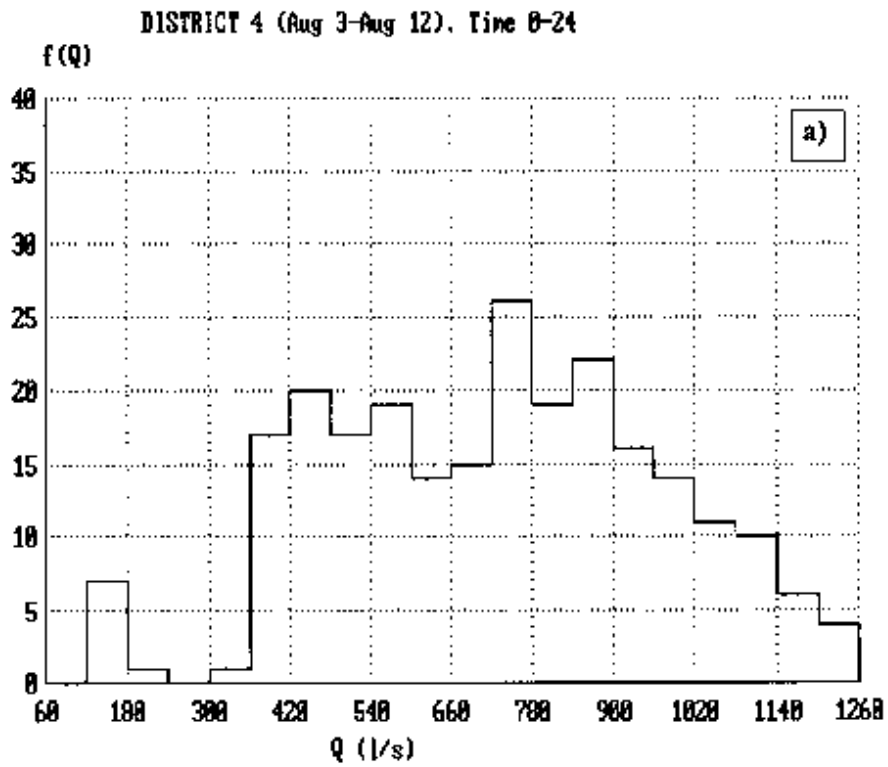

TABLE A4

Value of the r parameter obtained for different time intervals. Period from August 3 to August 12 ($q_s = 0.350 \text{ l s}^{-1} \text{ ha}^{-1}$)

Initial Time	Final Time	μ_{exp}	μ_{th}	σ_{exp}	σ_{th}	$\delta\sigma$	r
0	24	724.90	724.90	247.73	196.77	0.21	1.00
2	24	751.64	751.64	239.24	199.91	0.16	0.97
4	24	783.47	783.47	225.19	203.54	0.10	0.93
6	24	811.01	811.01	214.93	206.59	0.04	0.90
8	24	803.21	803.21	219.09	205.74	0.06	0.91
4	22	817.04	817.04	207.87	207.25	0.01	0.90

FIGURE A6

Discharge frequency histogram. Period from June 24 to July 3. Night-time withdrawals

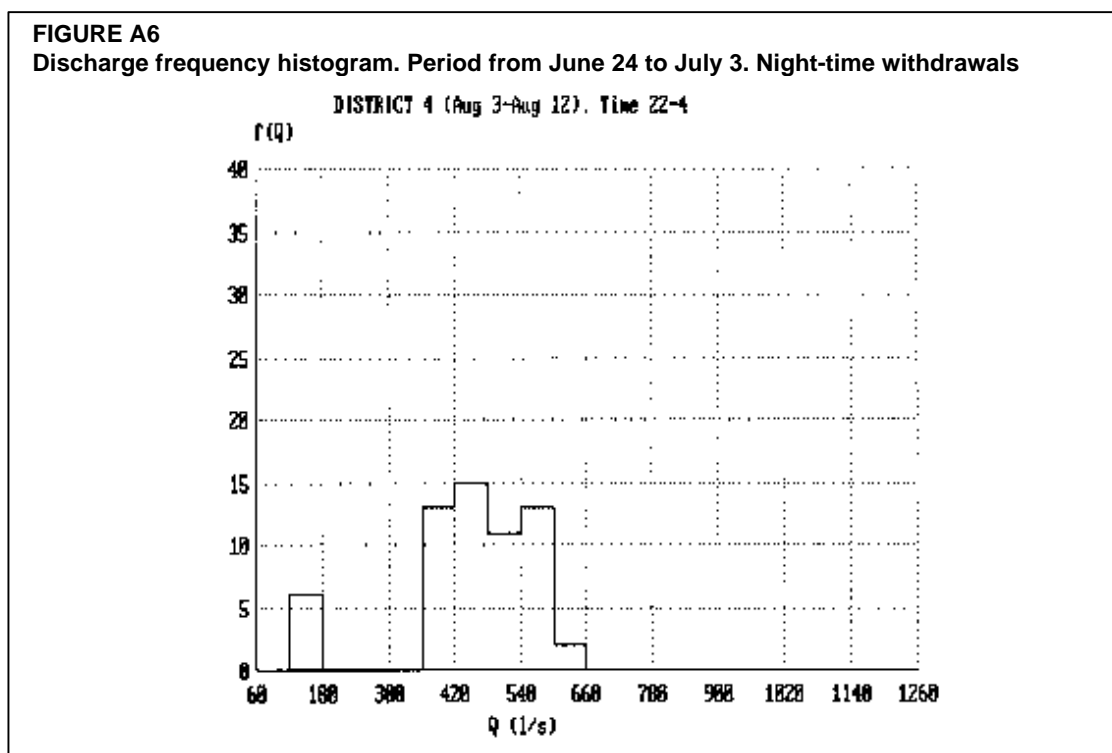

In particular, there is a good fit between the theoretical Gaussian curve and the histogram of frequencies obtained using the field data during daytime water withdrawals (Figures A4b and A5b). It means that the population of the discharges during this period is well represented by the Clément formula.

However, it is evident that the elimination of night-time data implies that night-time and daytime data belong to independent populations of discharge (which is evidenced when comparing Figures A5b and A6).

Considering that, in the study area, not all farms are equipped with automated irrigation systems and only few farmers prefer to irrigate during the night-time (for obtaining higher pressure), it is possible to consider the two populations as independent (night-time data and daytime data). Then the proposed approach seems valid. Clearly, it is necessary to verify every time through field data if the hypotheses on the basis of the Clément method are correct.

It is important to note that the minimum variation of standard deviation corresponds to a certain laps of time, t' (i.e., 16 hours for the 10-day peak period from June 24 to July 3),

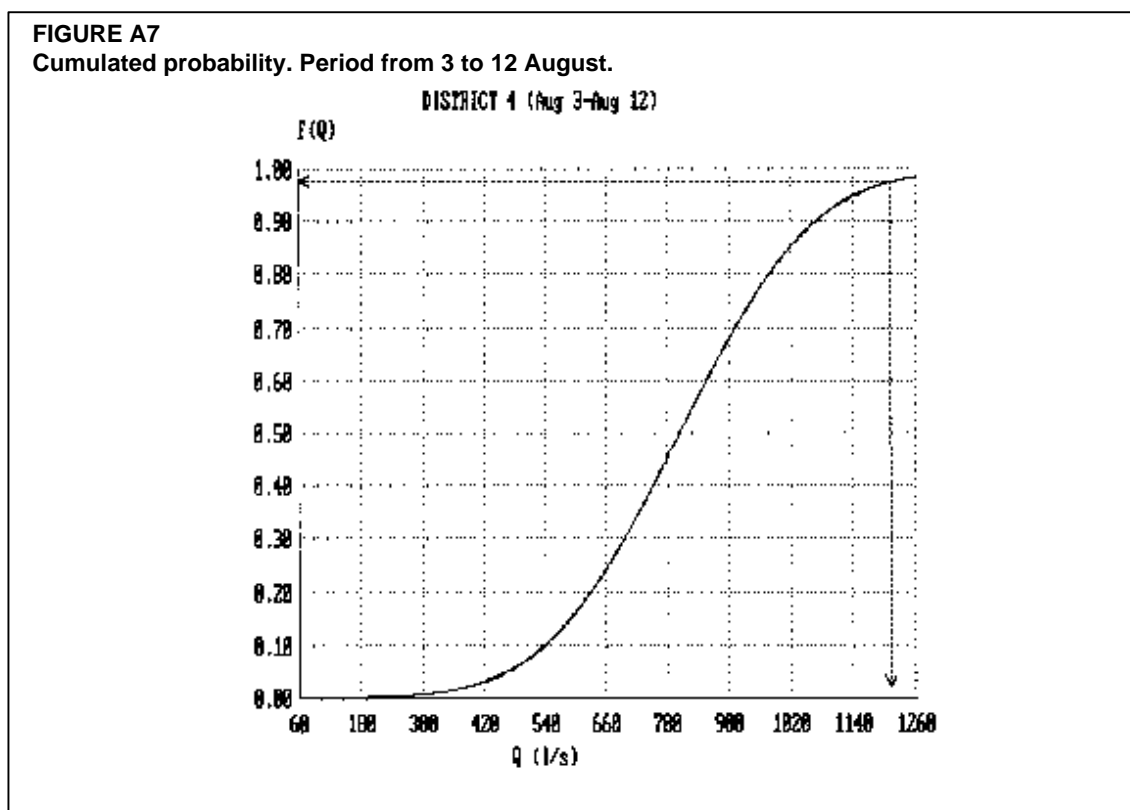

whereas the value of r does not correspond to the value of the ratio $t'/24$. Therefore, it is evident that the r coefficient should be intended only as a calibration coefficient aiming at understanding the farmer's behaviour. An irrigation system operating on-demand has to work 24 hours per day to allow for different withdrawals and to avoid dangerous simultaneously opening of hydrants.

From the above analysis, it is possible to calculate the integral curve, P_q , of the Gaussian distribution (Figure A7) and, consequently, to determine the $U(P_q)$ parameter of the Clément formula. For the peak period between August 3 and 10, i.e., the value of cumulated probability corresponding to the discharge of 1210 l s^{-1} (maximum discharge recorded in field) resulted to be $P_q = 0.976$ corresponding to $U(P_q) = 1.98$ (Figure A7).

Using a field survey, the r coefficient was calculated to clarify its meaning. For the studied case, r was close to 1 ($r=0.86$ and $r=0.90$ respectively for June 24 to July 3 and August 3 to August 12). The computed r is higher than the design value, $r = 0.67$. This means that a change occurred in the farmer's behaviour. In fact, the actual cropping pattern is different (Table A1) and more water is demanded than the designed pattern. Thus, the peak discharge should be higher. In order to avoid higher discharges in the network, with consequent failure of the hydraulic performance of the system, the farmers changed on-farm irrigation methods from sprinkler to trickle irrigation and have often adopted automated equipment. The water withdrawals became better distributed along the day (Figure A3), with less concentration in some hours. This is possible because the system operates 24 hours per day. Moreover, using field calculations, the Clément operation quality is $U(P_q)=1.98$. This corresponds to $P_q = 97.6\%$ (more than the designed value $P_q = 95\%$), and it implies a lower probability of exceeding the maximum discharge.

Annex 2

Pipe materials and design considerations

There are several advantages in using pipelines for conveyance in water distribution projects as well as for distribution on farm. Because of their capacity to transmit pressure, pipelines facilitate the use of flexible schedules. In fact, a farmer can open a valve on his farm in response to his irrigation need. This action can initiate a distant reaction to start flow from a gravity source or to start up a pump to satisfy the need in frequency, rate and duration of water flow. Essentially a pressure pipeline system is an automated system for transmitting and carrying out precise instructions. Furthermore, the use of pipelines in a conveyance system considerably reduces evaporation and seepage losses. Because they do not have to follow contours, pipelines can be laid with straight alignments and go up and down hills. Also, with the use of pumps and lifting plants, pipelines can convey water to higher elevation. In addition, the required right-of way width is considerably less relative to canals. The trench cross section and some suggested trench dimensions are reflected in Figure A8 and in Table A5.

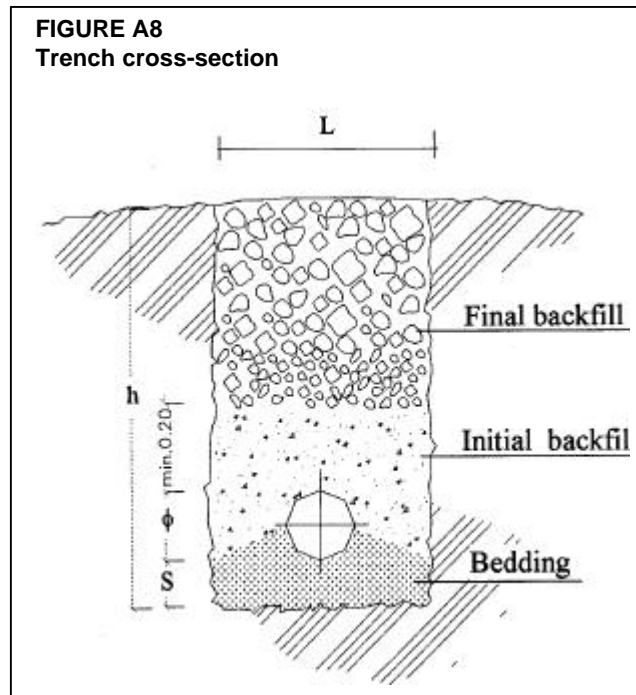

Since it is very difficult to make changes once pipelines have been installed, the designer must use great care when selecting the type of pipe, diameters and materials to insure that the initial installation is technically and economically acceptable and not limiting for the future. The following is a general overview on pipe types, materials and design considerations. Their main characteristics (nominal diameter, thickness, weight, working and breaking pressures) have not been included because of a great variability from country to country. Therefore the reader should obtain this information directly from concerned manufacturers.

PIPE MATERIALS AND DESIGN CONSIDERATIONS

With the advent of pipelines to convey irrigation water, a wide variety of materials were developed by the industry. Each different type of pipe has its own features. The engineer must

TABLE A5
Suggested trench cross-section dimensions

Nominal Diameter ϕ (mm)	Pipe Bed S (m)	Excavation Width L (m)	Excavation Depth h (m)
110	0.10	0.70	1.30
140	0.10	0.70	1.35
160	0.10	0.70	1.35
200	0.15	0.70	1.50
225	0.15	0.70	1.50
250	0.15	0.80	1.50
280	0.15	0.80	1.55
315	0.20	1.00	1.70
350	0.20	1.00	1.75
400	0.20	1.00	1.80
450	0.20	1.10	1.85
500	0.20	1.10	1.90
600	0.20	1.20	2.00
700	0.20	1.30	2.10
800	0.20	1.40	2.20

consider these characteristics in order to make sure that the selected type of pipe is suitable for that particular application. A wrong type of pipe can cause an increase of the construction costs for the Water Authority, a reduction of the system's life, higher annual maintenance and power costs, or can result in the system not working properly.

The characteristics of a pipe include:

- the material constituting the pipe;
- the nominal diameter, which is the one considered for hydraulic calculation;
- the length of pipe sections, which determines the number of joints for every km of pipeline;
- the wall thickness, which determines the maximum pressure of operation;
- the types of joints.

Different materials

Cast iron

Recently, cast iron pipes are produced by centrifugation of liquid cast iron in cylindrical shaped moulds (formerly called "shells"). Pipes are then fired to obtain a homogeneous texture. The so obtained pipes are coated with a thin zinc layer and finally sheltered with bituminous paint. When cast iron pipes have to be used in chemically aggressive soils, a polythene coating is applied. An internal mortar lining, 3 to 6 mm thick, is then applied by centrifugation in order to reduce roughness and to provide higher resistance to aggressive waters.

Cast iron pipes are commonly available in 60 mm through 700-mm diameters; higher diameters are also provided by manufacturers, when made to order. Thickness can range from 6 mm to 10.8 mm depending on the nominal pressure and diameter. Cast iron pipes are produced in 6-m length sections. The pipe sections are joined together by a bell and spigot joint (with a rubber ring gasket for sealing). Less frequently flanged joints are adopted. In fact, besides being more expensive, flanged joint does not allow for any altimetric or planimetric deflection. On the contrary, flanged joint is more suitable for systems with a high number of special parts.

Steel

Steel pipes are produced through a special rolling-mill process called “Mannesmann” process. The pipe is made from the hot rolling of a steel bar, without any welding. Steel pipes are also produced from large steel sheets, which are then welded along the generatrix or following a spiral shaped line.

Another process, the helical-shaped soldering, is used to produce steel pipes with very large diameters (2500 - 3000 mm). Steel pipes are commonly available in 40 mm up to 3000 mm diameters. Wall thickness can range from 2,6 mm for the 40 mm diameter (for a maximum PN of 14,5 Mpa) and 8,8 mm for the 900 mm diameter (for a maximum PN of 3,7 Mpa). The thickness is increased for pipes that are operated at high pressure. Sections are provided in 8 to 13,5 m lengths. Sections can be joined together both by bell and spigot joints and by flanged joints. Recently, due to the development of the electrical welding, the welded joining has become the most common type of joint for steel pipe sections.

Concerning the characteristics of the different types of joint, the bell and spigot joint is used for underground pipelines whereas flanged and welded joints are used for outdoor applications or for systems with a high number of special parts and devices.

Comparing cast iron pipes with steel pipes, cast iron pipes have higher wall thickness, with diameters and pressure being equal. This make cast iron pipes more suitable for soils with problem water and for areas where electrolytic corrosion is feared, as a result of stray electric currents. Besides, steel pipes have higher toughness and lower fragility, which reduce breakage. The higher specific traction strength of metal enables to produce pipes having lower wall thickness; therefore steel pipes are light-weight and cheaper than cast iron pipes. Steel pipes are more suitable for unsteady soils, as they stand ground movements without breaking.

Steel pipes are provided in greater lengths, which decreases the number of joints for every Km of aqueduct. Furthermore, their lightness, with regard to cast iron pipes, allows for easier and cheaper transportation. Thus, the selection between those two types of pipe is not an easy task. In the present circumstances, steel pipes are suitable for outdoor aqueducts. For underground applications, cast iron pipes are preferred, thanks to their higher resistance to electrolytic corrosion and when a high number of interruptions have to be made for diversions and for insertion of special parts and devices.

With regard to lining materials, very thick bituminous layers insure a satisfying inside protection of the steel pipes against strongly aggressive waters. Further, very good results have been accomplished by using epossidic paints.

An effective outside protection is obtained coating pipes with bituminous layers, glass wool or polyethylene. When welded joints are used, the heat resulting from welding destroys lining and coating near the joining edges. This can be a real drawback because the coating material can be easily replaced, but it is nearly impossible to restore the inside lining.

Concrete

Concrete pipe most commonly used for distribution systems in the past. Concrete pipes can be subdivided into pre-cast pipes and cast-in-place (monolithic) pipes. Pre-cast concrete pipes can be provided either with or without reinforcement. The latter are mainly utilized to convey water with a very low pressure (sewerage and drainage systems). In fact, concrete does not have high resistance against forces of traction resulting from the water pressure. Reinforced concrete pipes are suitable for much higher hydrostatic heads than the unreinforced ones. The range of internal pressure head they are designed for varies from 7,5 m to 37,5 m. Moreover, concrete

pipes are good to use when an external loading of soil is placed above the top of the pipe. The thickness of the walls and the type of reinforcement are varied according to the hydrostatic pressure head and to the external loading of any different application. The steel reinforcement can be a single or a double cage, circular or elliptical shaped. Recently, according to new production methods, the concrete is vibrated, consolidated and compacted to obtain a high density material that is watertight and not subject to pinhole leaks through the pipe barrel.

Diffuse reinforcement pipe is another recent innovation. This type of pipes has both cross and longitudinal reinforcement that are made from a high number of steel wires, which provide high resistance to the forces of traction. Furthermore, the high specific resistance of the material allows for pipes with reduced wall thickness. The diffuse reinforcement pipes are available in 400 mm to 1 400 mm diameters (for PN of 1.5 - 2 Mpa) while normal reinforced concrete pipes are produced in 600 mm to 2700 mm diameters. Reinforced concrete pipes are available in 2.4 m to 3.6 m lengths and the pipe sections are commonly joined together by a bell and spigot joint with a rubber ring gasket for sealing.

Cast-in-place pipes are mainly used for low-pressure head applications and for very large diameters. This kind of pipe is made by pouring concrete into metal forms, previously set to obtain a given wall thickness, and removing the forms and struts after the concrete has reached a sufficient level of strength. The result of the above process is a continuous pipeline without any joint, except for the expansion ones. This type of pipe is not suitable for expansive soils as multiple cracks can occur as a result of ground movements.

A third type of concrete pipe is the “continuous reinforcement” concrete pipe, also called “concrete cylinder” pipe or “Bonna” pipe. It is made of a steel cylinder, wrapped by a steel wire. The cylinder is also coated on both sides by cement mortar. The result of this process is a concrete pipe with a continuous reinforcement (steel cylinder). Pipe sections are connected with a bell-and-spigot joint, with a rubber gasket for sealing. In addition, sealing pipe sections by welding is possible. Continuous reinforcement concrete pipe is available in 12 m length sections and for diameters ranging from 300 mm to 1 350 mm. This type is suitable for pressure heads ranging from 70 m up to 350 m. The use of this type of pipe is also suggested to convey low-quality water, as the concrete coating and lining make an alkaline environment providing resistance against the corrosion of the cylinder.

Whatever the construction method of the concrete pipe is, particular care has to be taken in selecting the type of cement, its dosage, the water/cement ratio and the type of seasoning of the material obtained. The final purpose is to obtain a material with particular characteristics of impermeability.

Concrete pipes are, however, heavy compared to steel and cast iron pipes. This can affect the installation costs because less pipe is installed per day and because of the specialized construction equipment required.

Asbestos cement

Asbestos cement pipes are a typical component of water distribution systems. Asbestos cement pipes do not contain steel reinforcement, but they are composed of a mixture of cement mortar and asbestos fibres. Those fibres provide resistance to traction forces, the same function performed by steel wires in the reinforced concrete material. Asbestos cement pipes are formerly, but improperly, known as “Eternit” pipes, from the name of the first company that developed this technology.

The pipe material is obtained mixing asbestos fibres, cement mortar and water; with the dosage of each component is made by electronic devices. The resulting material is then further mixed to obtain high homogeneity in the mixture. Later, the mixture is poured on a rotating steel cylinder, until the desired wall thickness is reached. After that, the steel cylinder is taken off and the pipe is maturated in a ventilated tunnel. Lastly, the pipe goes in a hydration chamber to get a high level of mechanical strength.

Due to the production method used, asbestos cement pipes have good resistance to internal pressure, as asbestos fibres mainly orient in the direction of the cylinder. Therefore, breaks can occur as a result of longitudinal forces. This means that pipes need careful placement without external loading of soil above the pipe.

Asbestos cement pipes are provided in 600 mm diameter and smaller sizes. The maximum allowable internal pressure (hydrostatic) can be as high as 1.72 Mpa (175 m). This type of pipe is available in 3.9 m section length and the pipes are commonly joined together using Gibault or Simplex joints. Alternatively, one end of each pipe is machined to form a spigot, the other being provided with a collar. The spigot of a pipe is inserted into the collar of the subsequent pipe and two rubber gaskets are used for sealing the joint.

Asbestos cement pipes have a low roughness coefficient, a good chemical inertia, a good resistance to aggressive agents and a fairly good mechanical strength. These features encouraged their use in the past. Limits to their usefulness are their high weight, which makes transport and assembly more difficult. This is a big problem when pipes are laid underground in soils with a high colloidal fraction (expansive soils). Furthermore, the increasing concerns over toxicity of asbestos fibres resulted in many companies restricting or even ceasing their production. Also, their use has been drastically reduced over the last ten years by the diffusion of PVC, polyethylene and glassfibre pipes. Asbestos cement pipes are now widely used only for those situations imposing surface assembling such as in rocky or very high colloidal soils.

Plastic pipes

Over the last twenty years, a wide variety of plastic materials, composed by macro-molecules of carbonic compounds, such as Polystyrol, Polythene, Polypropylene and Polyvinyl Chloride have evolved. Each of these materials is made of thermoplastic resins enveloping a continuous or discontinuous fibrous phase. The plastic materials most commonly used for pipe production are Polyvinyl Chloride (PVC), Polyethylene (PE) and glass fibre reinforced Polyester (GFRP). The technology used for producing these materials is based on a chemical reaction, promoted by a catalytic agent, providing a macro-molecular structure of carbonic atoms (polymerization). For instance, Polyethylene is obtained through the polymerization of the molecule of ethylene. The polymers, when pure, are powder or grain shaped. Then, they are mixed with additive compounds to make them plastic and malleable. The resulting mixture is heated and then shaped to produce the pipe. The pipe is then water-cooled.

Plastic pipe features are very different from the steel and concrete pipes, as regard density, elasticity, resistance and thermal expansion coefficient. The best characteristics of the plastic pipes concern their resistance to corrosion (which can be caused by acids, alkaline compounds and organic fluids), their chemical inertia, their very low roughness coefficient, their lightness and their easiness in transport and placement. Moreover, they are adaptable to difficult and expansive soils.

Polyvinyl Chloride (PVC). Due to their indisputable advantages, Polyvinyl Chloride pipes have gained large acceptance in recent years. Until recently, they were available only in diameters ranging from 150 mm to 375 mm and were suitable for low-pressure head applications (from 15 m to 30 m). Due to progress in the production technology, PVC irrigation pipes are now produced for high-pressure head applications (56 m up to 70 m) and in 150 mm through 675 mm diameters. Pipe sections are commonly available in 6 m and 12 m lengths. Sections are joined together using bell and spigot joints with rubber gasket seals. In some cases the bell and spigot joint is further sealed with a solvent welding joint.

Since PVC possesses high flexibility, extra care is needed in bedding and back-filling to avoid an excessive deflection and distortion of the pipes. Another limit to the use of this type of pipes is their vulnerability to atmospheric agents. When placed outdoors, it is advisable to protect them with a coating. In those cases, PVC plastified pipes are preferred because of their special external “carbon black” protection.

Polythene (PE). Polythene pipes are widely used thanks to their advantages (e.g., lightness, handiness, low cost, flexibility, chemical inertia and resistance to atmospheric agents). The latter feature is provided by the “carbon black” additive, which protects the material from the action of solar rays.

Although the cost per metre is slightly higher than the PVC, Polythene pipes are more flexible and hence more widely used. Small diameters are available in large rolls and, therefore, pipe-layers are able to cut the soil and place the pipe in a single passage.

Polythene pipes are produced both in low (LDPE) and high density (HDPE). Low density polythene pipes have a slightly higher thickness, but they are more flexible and handy. The high density pipes have lower weight and, therefore, lower placement costs. Polythene pipes are available up to 1 200 mm diameter, but also in greater sizes when made to order. Wall thickness varies according to the class of pressure head (PN 2,5; PN 4; PN 6; PN 10; PN 16). They are produced in 6 or 12 m length. Pipes are joined together both by welding and flanged or plug joints. A good alternative to welding is electric welding where sections are connected by a hose clamp made of high density polythene. The hose contains an electric resistor providing the heat necessary for melting the three pieces together.

Glass wool reinforced polyester (GWRP). This type of material is made by adding glass fibre to a plastic mixture. This method produces pipes with higher mechanical strength than other plastic pipes. GWRP pipes can be coated with a layer of siliceous sand to protect them against ultraviolet rays. Sections are produced in 6 m and 12 m lengths and up to 2000 mm diameter. Sections are joined together by using the same types of joints as for the other plastic pipes.

Glassfibre Glassfibre pipes are widely used in large networks requiring large diameters. However, due to their relative higher cost for smaller diameters, they are not used for small networks. Glassfibre pipes are lighter than other materials but the very scarce availability of special parts limits their use. This is the reason why PVC and polythene pipes are preferred for small and medium diameter pipes.

Annex 3

Example of input and output files¹

```

***** Example of Network Input file *****

SN      IN      FN      Area  CQ_Hyd  Length  LandEl  ND  Hmin
24
1        0        1        2.2    2       150     96.20   250  20
2        1        2        2.2    2       462     95.80   250  20
3        2        3        2.2    2       162     96.30   250  20
4        3        4        2.2    2       118     97.50   250  20
5        4        5        2.2    2       80      98.40   250  20
6        5        6        0.00   0       112     101.10  250  20
7        6        7        0       0       250     100.00  250  20
8        7        8        0       0       13      100.10  200  20
9        8        9        2.2    2       63      98.80   180  20
10       9        10       2.2    2       50      98.00   180  20
11      10       11        0       0       83      96.80   180  20
12      11       12       2.2    2       30      96.00   140  20
13      12       13       2.2    2       30      95.70   140  20
14      13       14       2.2    2       63      95.30   140  20
15      14       15       2.2    2       35      95.20   140  20
16      15       16       2.2    2       40      95.00   140  20
17       7       17        0       0      315     100.30  250  20
18      17       18       2.2    2       413     102.00  200  20
19      18       19       2.2    2       173     103.00  200  20
20      19       20       2.2    2       43      102.80  200  20
21       6       21       2.2    2        1      101.10  180  20
22      21       22       2.2    2      123     103.00  140  20
23      22       23       2.2    2       75      103.80  110  20
24       8       24       2.2    2       63      99.50   110  20

ND      Thickness(mm)  (γ Bazin)  Cost (ITL/m)
110      5.3             .06       14000
125      6.0             .06       17700
140      6.7             .06       22100
160      7.7             .06       29300
180      8.6             .06       36500
200      9.6             .06       55000
225     10.8           .06       65000
250     11.9           .06       80000
280     13.4           .06       90000
315     15.0           .06      105000
450     00.0           .16      137000
500     00.0           .16      160000
600     00.0           .16      258000
700     00.0           .16      400000
800     00.0           .16      500000

*****
128      (upstream piezometric elevation, m a.s.l.)
0.327    (specific continuous discharge, l s-1 ha-1)
0.0      (uncultivated land, %)
0.667    (Use coefficient, r)
3        (Number of hydrants simultaneously operating)
20.0     (Minimum pressure head, m)
1.645    (Operation quality, U(Pq))

```

¹ Note that input and output files in the COPAM package are SCI files. Therefore they can be easily imported into other software (like Excel).

* Example of output file of the Clement optimization program *

```
*****
*
SN   IN   FN   Area   N.Hydr   Qcl   Diam   LandEl   L   H   Y   PiezEl   v
      (l/s) (l/s) (mm) (m asl) (m) (m) (m) (m asl) (m/s)
*****
*
  1    0    1  41.8   19  50.0   315   96.20  150.0  31.54  0.26  127.74  0.64
  2    1    2  39.6   18  50.0   315   95.80  462.0  31.15  0.79  126.95  0.64
  3    2    3  37.4   17  40.0   280   96.30  162.0  30.33  0.33  126.63  0.65
  4    3    4  35.2   16  40.0   280   97.50  118.0  28.89  0.24  126.39  0.65
  5    4    5  33.0   15  40.0   280   98.40  80.0   27.83  0.16  126.23  0.65
  6    5    6  30.8   14  40.0   280  101.10  112.0  24.90  0.23  126.00  0.65
  7    6    7  24.2   11  30.0   250  100.00  250.0  25.49  0.51  125.49  0.61
  8    7    8  17.6    8  30.0   160  100.10  13.0   25.11  0.27  125.21  1.49
  9    8    9  15.4    7  30.0   160   98.80  63.0   25.08  1.33  123.88  1.49
 10   9   10  13.2    6  30.0   160   98.00  50.0   24.83  1.06  122.83  1.49
 11  10   11  11.0    5  30.0   160   96.80  83.0   24.28  1.75  121.08  1.49
 12  11   12  11.0    5  30.0   160   96.00  30.0   24.28  0.80  120.28  1.49
 13  12   13  8.8    4  30.0   140   95.70  30.0   23.31  1.27  119.01  1.95
 14  13   14  6.6    3  30.0   140   95.30  63.0   21.03  2.67  116.33  1.95
 15  14   15  4.4    2  20.0   140   95.20  35.0   20.47  0.66  115.67  1.30
 16  15   16  2.2    1  10.0   110   95.00  40.0   20.00  0.67  115.00  1.05
 17    7   17  6.6    3  30.0   250  100.30  315.0  24.44  0.75  124.74  0.61
 18   17   18  6.6    3  30.0   225  102.00  413.0  21.27  1.47  123.27  0.75
 19   18   19  4.4    2  20.0   225  103.00  173.0  20.00  0.27  123.00  0.50
 20   19   20  2.2    1  10.0   160  102.80  43.0   20.00  0.20  122.80  0.50
 21    6   21  6.6    3  30.0   180  101.10  1.0   24.89  0.01  125.99  1.18
 22   21   22  4.4    2  20.0   160  103.00  123.0  21.44  1.55  124.44  0.99
 23   22   23  2.2    1  10.0   125  103.80  75.0   20.00  0.64  123.80  0.81
 24    8   24  2.2    1  10.0   110   99.50  63.0   24.65  1.06  124.15  1.05
*****
*
```

***** ANALYSIS OF COSTS *****

DIAM (mm)	Length (m)	COST (ITL)
110	103.0	1442000
125	75.0	1327500
140	128.0	2828800
160	405.0	11866500
180	1.0	36500
225	586.0	38090000
250	565.0	45200000
280	472.0	42480000
315	612.0	64260000

***** TOTAL COST : 207531296.0 *****

SN= Section Number; IN= Initial Node; FN = Final Node;
 Q_Hydr = Hydrant discharge; CQ_Hyd = Code Hydrant discharge;
 LandEl = Land elevation; Qcl = Discharge;
 Diam = Diameter; L=Length; H = Residual head; Y = Head losses;
 PiezEl = Piezometric elevation; v= Flow velocity;
 Area = area served by each section; N.Hydr = Number of hydrants
 downstream each section; Hmin = Minimum pressure head at the node.